

# INSTRUCTIONS-PARTS LIST



This manual contains important warnings and information.  
**READ AND KEEP FOR REFERENCE.**

INSTRUCTIONS

## GMax™ 5900 Convertible Airless Paint Sprayers

309411 rev.D

*–For Portable Airless Spraying of Architectural Coatings and Paints –*

### 5.5 HORSEPOWER, GASOLINE POWERED

*3300 psi (228 bar, 22.8 MPa) Maximum Working Pressure*

Model	Series	Description
233709	A	Sprayer, gas powered
233710	A	Sprayer, gas powered, with RAC® X tip, gun and hose
233711	A	Sprayer, gas powered, with electric motor kit
233712	A	Same as 233711 except with ETL approval to CSA and UL standards
233713	A	Sprayer, gas powered, with Lo-Boy suction set kit
233714	A	Sprayer, gas powered, with RAC X tip, gun and hose and Lo-Boy suction set kit
233715	A	Sprayer, gas powered, with Lo-Boy suction set kit and electric motor kit

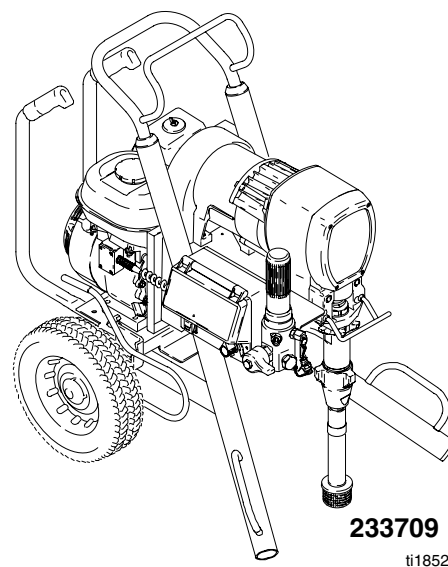

### Related Manuals

Operator .....	309410
Displacement Pump .....	309277
Spray Gun .....	309639
Spray Tip .....	309640
AutoClean Kit .....	309450
PC Board .....	309459
Electric Motor Kit .....	309469
Drain Valve Kit .....	308961

GRACO INC. P.O. BOX 1441 MINNEAPOLIS, MN 55440-1441

COPYRIGHT 2002, GRACO INC.

Graco Inc. is registered to I.S. EN ISO 9001

# Table of Contents

Component Identification and Function . . . . .	5	Parts	
Maintenance . . . . .	6	Basic Sprayer . . . . .	18
Troubleshooting . . . . .	7	Pinion Assembly . . . . .	21
Repair		Pressure Control . . . . .	22
Bearing Housing and Connecting Rod . . . . .	9	Wiring Schematic . . . . .	23
Drive Housing . . . . .	10	Clutch Assembly . . . . .	24
Pinion Assembly/Rotor/Field/Shaft/Clutch/Pulley . . . . .	11	Complete Sprayer . . . . .	24
ON/OFF Switch . . . . .	13	Lo-Boy Suction Set Kit . . . . .	25
Pressure Control Repair . . . . .	14	Technical Data . . . . .	25
Displacement Pump Repair . . . . .	16	Dimensions . . . . .	25
		Graco Warranty . . . . .	26

## Warnings and Cautions

### Warning Symbol



This symbol alerts you to the possibility of serious injury or death if you do not follow the instructions.

The wallet-sized warning card provided with this pole gun should be kept with the operator at all times. The card contains important treatment information should a fluid injection injury occur. Additional cards are available at no charge from Graco Inc.

### Caution Symbol



This symbol alerts you to the possibility of damage to or destruction of equipment if you do not follow the instructions.

# ⚠ WARNING



## SKIN INJECTION HAZARD

Spray from the spray tip, hose leaks or ruptured components can inject fluid into your body and cause extremely serious injury, including the need for amputation. Splashing fluid in the eyes or on the skin can also cause serious injury.

- Fluid injected into the skin might look like just a cut, but it is a serious injury. **Get immediate surgical treatment!**
- Do not point the spray tip at anyone or any part of the body.
- Do not put hand or fingers over the spray tip, and do not stop or deflect fluid leaks with your hand, body, glove or rag.
- Do not “blow back” fluid; this is not an air spray system.
- Always have the tip guard and the trigger guard on the in-line valve when spraying.
- Be sure the trigger safety lever operates before operating the in-line valve.
- Lock the trigger safety lever when you stop spraying.
- Follow the **Pressure Relief Procedure** on page 6 when you are instructed to relieve pressure; stop spraying; check, clean, or service any system equipment; or install or change spray tips.
- Tighten all fluid connections before each use.
- Check the hoses, tubes and couplings daily. Replace worn or damaged parts immediately. Permanently coupled hoses cannot be repaired.
- Handle and route hoses and tubes carefully. Keep hoses and tubes away from moving parts and hot surfaces. Do not use the hoses to pull equipment. Do not expose Graco hoses to temperatures above 150°F (65°C) or below -40°F (-40°C).



## TOXIC FLUID HAZARD

Hazardous fluids or toxic fumes can cause a serious injury or death if the fluid is swallowed or splashed in the eyes or on the skin or if the fumes are inhaled.

- Know the specific hazards of the fluid you are using.
- Store hazardous fluid in an approved container. Dispose hazardous fluid according to all local, state and national guidelines.
- Dress appropriately for your application. Wear protective eyewear, noise protection for the ears, a personal respirator, gloves, and clothing.



## RECOIL HAZARD

Due to the high pressure fluid emitted, a strong recoil action may occur when you trigger the pole gun. If you are unprepared, your hand could be forced back toward your body or you could lose your balance and fall, resulting in serious injury.

# WARNING



## FIRE AND EXPLOSION HAZARD

Improper grounding, poor air ventilation, open flames, or sparks can cause a hazardous condition and result in fire or explosion and serious injury.

- Ground the equipment and the object being sprayed.
- Provide fresh air ventilation to avoid the buildup of flammable fumes from solvent or the fluid being sprayed.
- Extinguish all the open flames or pilot lights in the spray area.
- Electrically disconnect all the equipment in the spray area.
- Keep the spray area free of debris, including solvent, rags, and gasoline.
- Do not turn on or off any light switch in the spray area while operating or if fumes are present.
- Do not smoke in the spray area.
- Do not operate a gasoline engine in the spray area.
- If there is any static sparking while using the equipment, **stop spraying immediately**. Identify and correct the problem.



INSTRUCTIONS

## EQUIPMENT MISUSE HAZARD

Equipment misuse can cause the equipment to rupture, malfunction, or start unexpectedly and result in serious injury.

- This equipment is for professional use only.
- Read all instruction manuals, tags, and labels before operating the equipment.
- Use the equipment only for its intended purpose. If you are uncertain about the usage, call your distributor.
- Do not alter or modify this equipment. Use only genuine Graco parts and accessories.
- Check the equipment daily. Repair or replace worn or damaged parts immediately.
- Do not exceed the maximum working pressure of the lowest rated system component. This equipment has a **3600 psi (25 MPa, 248 bar) maximum working pressure**.
- Route the hoses away from the traffic areas, sharp edges, moving parts, and hot surfaces. Do not expose Graco hoses to temperatures above 150°F (65°C) or below -40°F (-40°C).
- Do not use the hoses to pull the equipment.
- Use fluids or solvents that are compatible with the equipment wetted parts. See the **Technical Data** section of all the equipment manuals. Read the fluid and solvent manufacturer's warnings.
- Fluid hoses must have spring guards on both ends to protect them from rupture caused by kinks or bends near the couplings.
- Comply with all applicable local, state and national fire, electrical and other safety regulations.
- Wear hearing protection when operating this equipment.



## HAZARD OF USING FLUIDS CONTAINING HALOGENATED HYDROCARBONS

Never use 1,1,1-trichloroethane, methylene chloride, other halogenated hydrocarbon solvents or fluids containing such solvents in this equipment. Such use could result in a serious chemical reaction, with the possibility of explosion, which could cause death, serious injury and/or substantial property damage.

Consult your fluid suppliers to ensure that the fluids being used are compatible with aluminum and zinc parts.

# Component Identification and Function

**Engine On/Off Switch**



**Pump On/Off Switch**

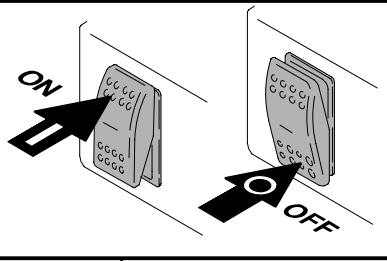

**Pressure Control**

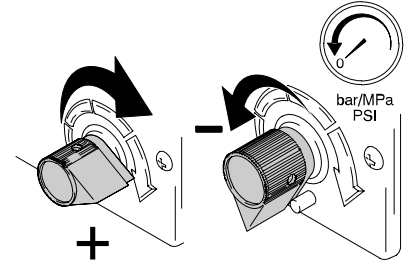

**Engine Controls**

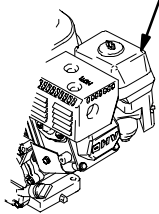
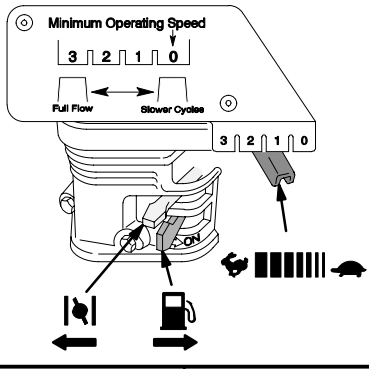

**Spray Gun Trigger Lock**

Reference your Spray Gun Manual

**Prime/Drain Valve**

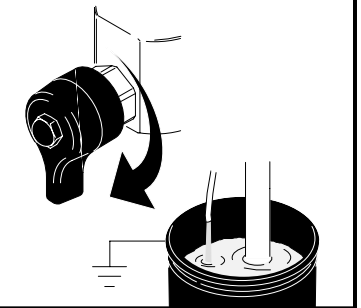

**Motor On/Off Switch**

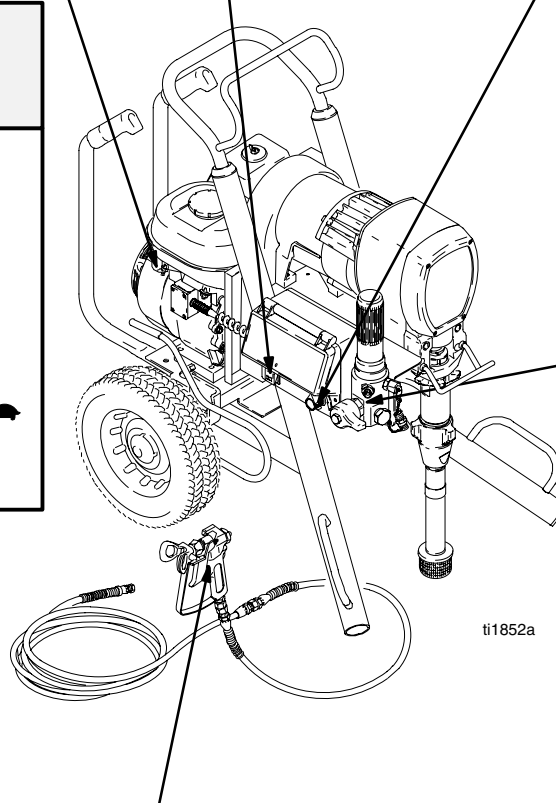
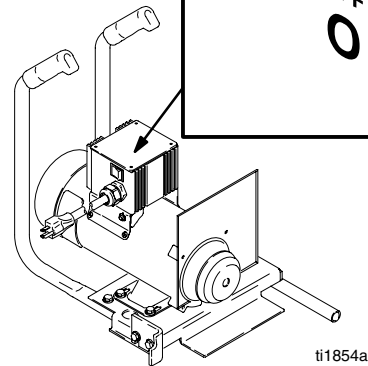
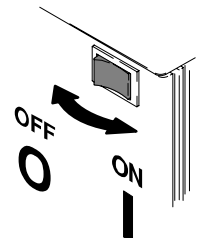

ti1852a

ti1854a

# Maintenance

## ⚠ WARNING



### INJECTION HAZARD

System pressure must be manually relieved to prevent system from starting or spraying accidentally. Fluid under high pressure can be injected through skin and cause serious injury. To reduce risk of injury from injection, splashing fluid, or moving parts, follow **Pressure Relief Procedure** whenever you:

- are instructed to relieve pressure,
- stop spraying,
- check or service any system equipment,
- or install or clean spray tip.

## Pressure Relief Procedure

1. Lock gun safety latch.
2. Turn engine or electric motor ON/OFF switch to OFF.
3. Unplug power supply cord (electric motor).
4. Move pressure control switch to OFF and turn pressure control knob fully counterclockwise.
5. Rotate RAC 5 tip, if used, to reverse position.
6. Unlock gun safety latch. Hold metal part of gun firmly to grounded metal pail. Trigger gun to relieve pressure.
7. Lock gun safety latch.
8. Open pressure drain valve. Leave pressure drain valve open until ready to spray again.

*If suspected that spray tip or hose is completely clogged, or that pressure has not been fully relieved after following steps above, VERY SLOWLY loosen tip guard retaining nut or hose end coupling to relieve pressure gradually, then loosen completely. Now clear tip or hose obstruction.*

## ⚠ CAUTION

For detailed engine maintenance and specifications, refer to separate engine manual, supplied.

**DAILY:** Check engine oil level and fill as necessary. Manual 309410.

**DAILY:** Check that V-belt (60) is centered on pulleys and is not inverted. Replace if worn or damaged.

**DAILY:** Check and fill gas tank.

**DAILY:** Check hoses for wear and damage.

**DAILY:** Check gun safety for proper operation.

**DAILY:** Check pressure drain valve for proper operation.

**AFTER THE FIRST 20 HOURS OF OPERATION AND EACH 100 HOURS THEREAFTER:** Change engine oil.

**DAILY:** Keep TSL in packing nut to help lubricate pump packings. One full squirt of TSL is usually enough.

**WEEKLY:** Remove cover of air filter (C) and clean element. Replace element, if necessary. If operating in an unusually dusty environment, check filter daily and replace it, if necessary.

Repack connecting rod (22) top needle bearing after every pump change.

Replacement elements can be purchased from your local HONDA dealer.

**SPARK PLUG:** Use only an BPR6ES (NGK) or W20EPR-U (NIPPONDENSO) plug. Gap plug to 0.028 to 0.031 in. (0.7 to 0.8 mm). Use a spark plug wrench when installing and removing plug.

# Troubleshooting



Relieve pressure; page 6.

PROBLEM	CAUSE	SOLUTION
E=XX is displayed	Fault condition exists	Determine fault correction from table, page 14.
Engine won't start	Engine switch is OFF	Turn engine switch on.
	Engine is out of gas	Refill gas tank. Honda Engines Owner's Manual.
	Engine oil level low	Try to start engine. Replenish oil, if necessary. Honda Engines Owner's Manual.
	Spark plug cable disconnected or spark plug damaged	Connect spark plug cable or replace spark plug.
	Oil seepage into combustion chamber	Remove spark plug. Pull starter rope 3 or 4 times. Clean or replace spark plug. Try to start engine. Keep sprayer upright to avoid oil seepage.
False tripping of WatchDog system. <b>EMPTY</b> is displayed. Pump does not run.	Operating conditions out of WatchDog parameters	Turn pressure down. Contact Graco Technical Service to adjust WatchDog parameters. Operate without WatchDog active; Manual 309410.
	Low pump output; page 8.	
Engine operates, but displacement pump doesn't	Pressure control switch turned OFF	Turn on.
	Pressure setting too low	Increase pressure.
	Displacement pump outlet filter dirty	Clean filter.
	Tip or tip filter clogged	Clean tip or tip filter.
	Broken drive belt	Replace belt.
	Displacement pump rod seized by dry paint	Service pump. See page 16.
	Connecting rod worn or damaged	Replace. See page 9.
	Drive housing worn or damaged	Replace. See page 10.
	Electrical power is not energizing clutch field	Check wiring connections. Page 23. Reference pressure control repair. Page 14. Reference wiring diagram. Page 23.  With pump switch ON and pressure turned to MAXIMUM, use a test light to check for power between clutch test points on control board.  Remove 7-pin connector from control board and measure resistance across clutch coil. At 70° F, the resistance must be 1.7 ±0.2Ω; if not, replace pinion housing.  Have pressure control checked by authorized Graco dealer.
	Clutch is worn, damaged, or incorrectly positioned	Replace clutch. Page 11.
Pinion assembly is worn or damaged	Repair or replace pinion assembly. Page 11.	

PROBLEM	CAUSE	SOLUTION
Pump output low	Strainer (31) clogged	Clean.
	Piston ball (25) not seating	Service piston ball check. Manual 309277.
	Piston packings worn or damaged	Replace packings. Manual 309277.
	Displacement pump o-ring (227) is damaged	Replace o-ring. Manual 309277.
	Intake valve ball not seating properly	Clean and service. Manual 309277.
	Engine speed is too low	Increase throttle setting. See Manual 309410.
	V-belt slipping	Tighten V-belt with tension bar (101). Adjust bracket until it takes 15 lb of force to lock tension bar down.
	Clutch worn or damaged	Replace. See page 11.
	Pressure setting is too low	Increase pressure. Manual 309410.
	Fluid filter (318), tip filter or tip is clogged or dirty	Clean filter. Manual 309410 or 309091.
	Large pressure drop in hose with heavy materials	Use larger diameter hose and/or reduce overall length of hose. Use of more than 100 ft of 1/4 in. hose significantly reduces performance of sprayer. Use 3/8 in. hose for optimum performance (50 ft minimum).
Excessive paint leakage into throat packing nut	Throat packing nut is loose	Remove throat packing nut spacer. Tighten throat packing nut just enough to stop leakage.
	Throat packings worn or damaged	Replace packings. Manual 309277.
	Displacement rod worn or damaged	Replace rod. Manual 309277.
Spitting from gun	Air in fluid pump or hose	Check and tighten all fluid connections. Reprime pump. Manual 309410.
	Tip partially clogged	Clear tip. Manual 309091.
	Fluid supply is low or empty	Refill and prime pump. See <b>Startup</b> , Manual 309410. Check fluid supply often to prevent running pump dry.
Pump is difficult to prime	Air leak	Check and tighten all fluid connections. Reduce engine speed and cycle pump as slowly as possible during priming.
	Intake valve is leaking	Shut off pump and relieve pressure. Disassemble and clean intake valve. Be sure ball seat is not nicked or worn and that ball seats well. Reassemble.
	Worn packings	Repack pump. Manual 309277.
	Fluid is too thick	Thin fluid according to supplier's recommendations.
	Engine speed is too high	Decrease throttle setting before priming pump. Manual 309410.
Clutch squeaks each time clutch engages	Clutch surfaces are not matched to each other when new and may cause noise	Clutch surfaces need to wear into each other. Noise will dissipate after a day of run time
High engine speed at no load	Misadjusted throttle setting	Reset throttle to 3700 engine rpm at no load
	Worn engine governor	Replace or service engine governor
Gallon counter not working	Bad sensor, broken or disconnected wire	Check connections. Replace sensor or wire.
No display, sprayer operates	Display damaged or has bad connection	Check connections. Replace display.



# Bearing Housing and Connecting Rod

## Removal

- 
 Relieve pressure; page 6.
- Stop sprayer at bottom of stroke to get crank (E) in lowest position. To lower crank manually, remove spark plug and carefully rotate crank by pulling starter rope.
- Fig. 2. Remove front cover (38). Unclip drain hose (74) from pump. Unscrew pump suction tube (73) from pump. Disconnect pump hose (167).
- Push up retaining spring (59). Push pin (58) out rear.

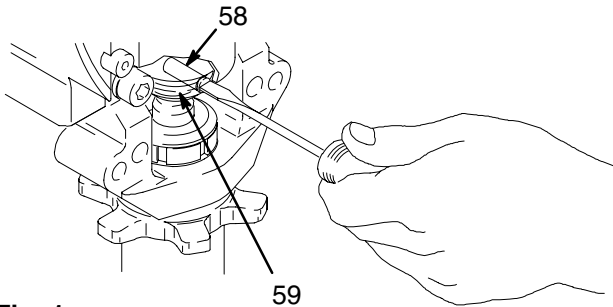

Fig. 1 7675B

- Loosen locknut (57). Unscrew displacement pump (48).
- Remove four screws and lockwashers (20, 19).
- Tap lower rear of bearing housing (60) with a plastic mallet to loosen from drive housing (3). Pull bearing housing and connecting rod assembly (40) straight off drive housing.
- Remove pail hanger (105) and install it on new bearing housing.
- Inspect crank (E) for excessive wear and replace parts as needed.

## Installation

- Evenly lubricate inside of bronze bearing (B) in bearing housing (60) with high-quality motor oil. Liberally pack top roller bearing (C), lower bearing (D) inside connecting rod assembly (40) with bearing grease 114819.

- Assemble connecting rod (40) and bearing housing (60).
- Clean mating surfaces of bearing and drive housings (60, 3).
- Align connecting rod (C) with crank (E) and drive housing locating pins (3b) with bearing housing (60) holes. Push bearing housing onto drive housing or tap into place with plastic mallet.

## ⚠ CAUTION

Do not use bearing housing screws (19) to align or seat bearing housing; this may cause bearing and drive housing misalignment and result in premature bearing wear.

- Install screws and lockwashers (20, 19). Tighten screws evenly to 25 ft-lb (34 N·m).
- Install pump; page 16.
- Fig. 2. Install remaining parts.

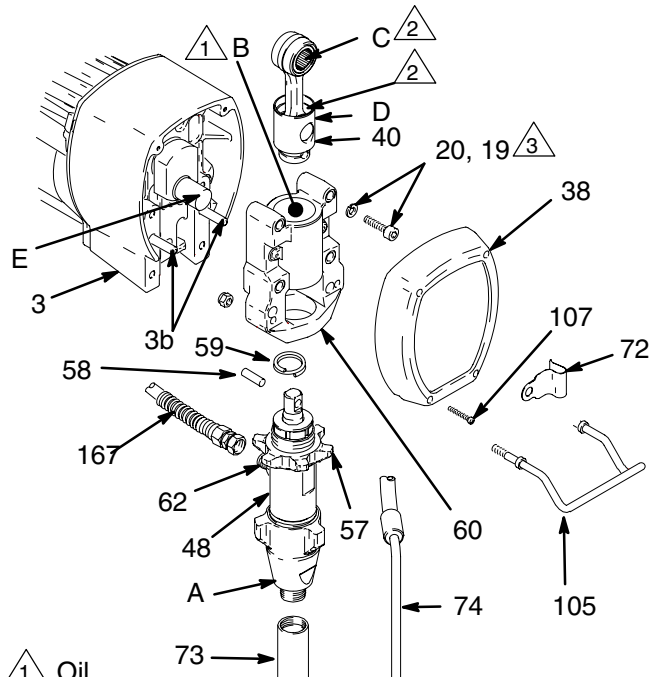



-  Oil
-  Pack with bearing grease 114819
-  Torque to 25 ft-lb (34 N·m)

Fig. 2 8697B

# Drive Housing

## Removal



1. Relieve pressure; page 6.
2. Disconnect reed switch (A).
3. Fig. 3. Remove bearing housing. Do **Removal of Bearing Housing and Connecting Rod** procedure on page 9.
4. Remove two screws (31) and lockwashers (37).
5. Remove four screws (35) and lockwashers (34) from pinion housing (4).
6. Lightly tap around drive housing (3) to loosen drive housing. Pull drive housing straight off pinion housing (4). Be prepared to support gear cluster (36) which may also come out.

## CAUTION

Do not drop gear cluster (36) when removing drive housing (3). Gear cluster is easily damaged. Gear may stay engaged in drive housing or pinion housing.

## Installation

1. Liberally apply bearing grease (supplied with replacement gear cluster) to gear cluster (36) and to areas called out by note 2. Use full 0.68 pint (0.32 liter) of grease.
2. Place bronze colored washer (3g) on shaft protruding from large shaft of drive housing (3). Note: If replacing a washer with pin holes with a washer without pin holes, remove guide pins from housing. Place silver colored washer (3h) on pinion housing. Assemble washers (61) and (62) onto gear (36). Align gears and push new drive housing straight onto pinion housing and locating pins (B).

3. Install four screws (47) and lockwashers (37) to pinion housing (4) and drive housing (3).
4. Install two screws (31) and lockwashers (37) to drive housing (3).
5. Fig. 3. Install bearing housing. Do 1. through 6. of **Bearing Housing and Connecting Rod** procedure on page 9.
6. Connect reed switch (A).

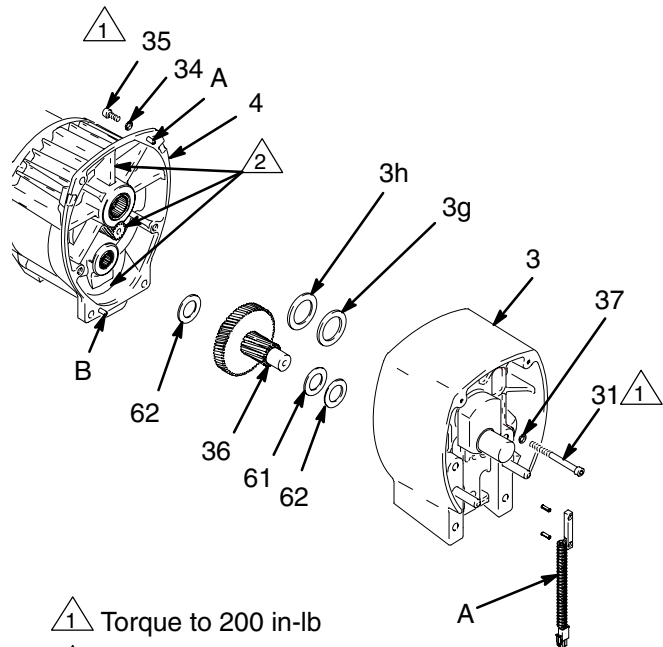

Fig. 3

T11889a

# Pinion Assembly/Rotor/Shaft/Clutch/Pulley

## Removal

1. If pinion assembly (4) is not removed from clutch housing (169), do 2. through 5. Otherwise, do 2. and then start at 6.

2.  Relieve pressure; page 6.

3. Disconnect field cable (X) from pressure control and reed switch (A).

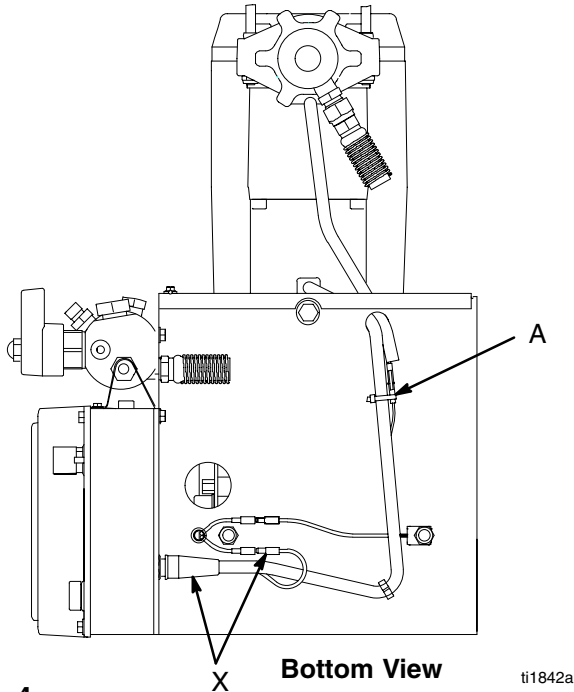

Fig. 4

4. Fig. 5. Remove five screws (47) and lockwashers (37) and pinion assembly (4).

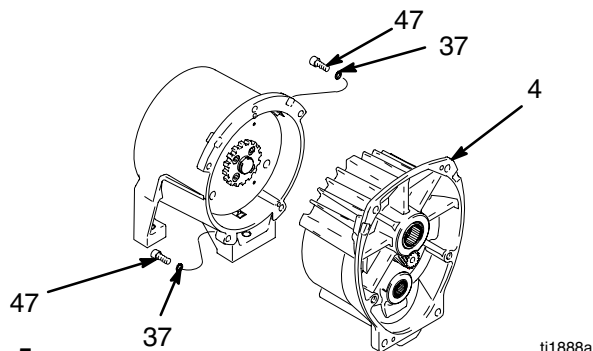

Fig. 5

5. Fig. 6. Place pinion assembly (4) on bench with rotor side up.

6. Remove four screws (16) and lockwashers (37). Install two screws in threaded holes (E) in rotor. Alternately tighten screws until rotor comes off.

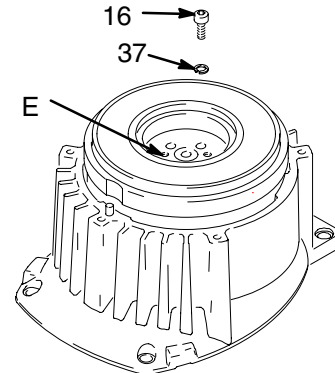

Fig. 6

7. Fig. 7. Remove retaining ring (169b).
8. Tap pinion shaft (169c) out with plastic mallet.

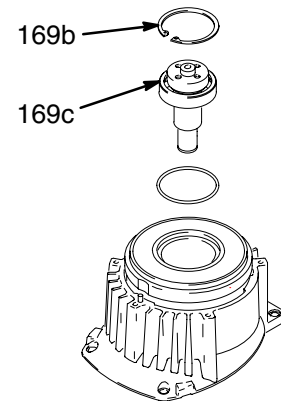

Fig. 7

9. Fig. 9. Remove belt guide bracket (171), belt guard (117) and vee belt (103).
10. Hold pulley (53) and remove four screws (88) and washers (37) from hub (94). Remove armature (86) and spacer (169f).
11. **Engine Detail**, page 20. Remove screw (101) and washer (166) from engine drive shaft. Remove pulley (53) and motor shaft sleeve (170). Remove pulley and key (41).
12. Fig. 9. Remove three screws (63) from beneath mounting plate (D).
13. Lift off clutch housing (169).
14. Remove retaining ring (169b). Pull jack shaft assembly (169c) out.

# Pinion Assembly/Rotor/Shaft/Clutch/Pulley

## Installation

1. Fig. 9. Install jack shaft assembly (169c). Install retaining ring (169b).
2. Fig. 8. Lay two stacks of two dimes on smooth bench surface.
3. Lay armature (86) on two stacks of dimes.
4. Press hub (94) down on bench surface.

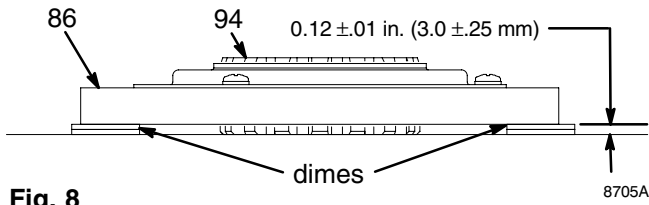

Fig. 8

5. Fig. 9. Place spacer (169f) and armature (94, 86) on jack shaft assembly (169c).
6. Install three screws (63) through mounting plate (D) and into clutch housing (169).
7. Apply Loctite® to screw (101). Install screw, washer (166), key (41) and pulley (53) in end of jack shaft assembly (169c). End of jackshaft (169c) must be 0.090 in. below flush with end of bushing.

8. Hold pulley (53) and install four screws (88) and washers (37) in hub (94). Torque to 125 in-lb (14 N·m).
9. Install belt guard (117), belt guide bracket (171) and vee belt (103).
10. Fig. 7. Tap pinion shaft (169c) in with plastic mallet.
11. Install retaining ring (169b).
12. Fig. 6. Place pinion assembly on bench with rotor side up.
13. Apply Loctite to screws. Install four screws (16) and lockwashers (37). Alternately torque screws to 125 in-lb until rotor is secure.
14. Push pinion housing (4) assembly onto clutch housing (169e). Tap lightly on front of bearing housing (17) with a plastic mallet to push drive housing and pinion housing assembly onto clutch housing.
15. Install pinion assembly with five screws (47) and lockwashers (37).
16. Fig. 4. Connect field cable (X) to pressure control.
17. Page 10. Do **Drive Housing, Installation**.

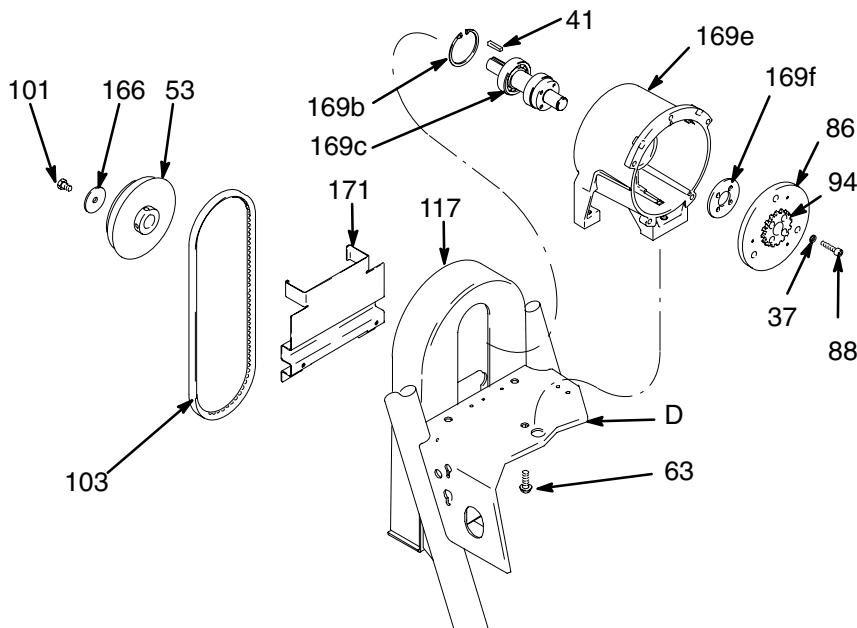

Fig. 9

ti1853a



# Pressure Control

## Control Board

### Removal

-  1. Relieve pressure; page 6.
2. Fig. 10. Remove four screws (11) and display/cover (12). Pull display connector wings open on PC board and pull display connector out.
3. Fig. 17. Disconnect at control board (147):
  - Lead (D) from potentiometer.
  - Lead (E) from transducer.
  - Remove ON/OFF switch (51) at connector (A).
4. Fig. 10. Remove six screws (44) from control board (147) and green ground wire.
5. Remove connector (Ref 4) at backside of pressure control. Remove jam nut (147a) and control board (147).

### Installation

When installing replacement control board, follow instructions with control board to set model type.

1. Fig. 10. Install control board (147) and jam nut (147a). Install connector (Ref 4) at backside of pressure control.
2. Install green ground wire and control board (147) with six screws (44).
3. Fig. 17. Connect to control board (147):
  - Connect ON/OFF switch (51) connector (A).
  - Lead (E) to transducer.
  - Lead (D) to potentiometer.
4. Fig. 10. Push display connector into PC board close display connector wings on PC board. Install display/cover (12) with four screws (11).

## Pressure Control Transducer

### Removal

-  1. Relieve pressure; page 6.
2. Fig. 10. Remove four screws (11) and display/cover (12).
3. Disconnect lead (E) from control board (147).
4. Remove two screws (141) and transducer guard (178) from control housing (8). Pull transducer connector through rubber grommet (176).
5. Remove pressure control transducer (100q) and o-ring (100p) from filter housing (100e).

### Installation

1. Fig. 10. Install o-ring (100p) and pressure control transducer (100q) in filter housing (100e). Torque to 30–36 ft-lb.
2. Install transducer connector and rubber grommet (176) in control housing (8). Install transducer guard (178) on control housing with two screws (141).
3. Connect lead (E) to control board (147).
4. Install display/cover (12) with four screws (11).

## Pressure Adjust Potentiometer

### Removal

-  1. Relieve pressure; page 6.
2. Fig. 10. Remove four screws (11) and display/cover (12).
3. Disconnect lead (D) from control board (147).
4. Loosen set screws on potentiometer knob (13) and remove knob, shaft nut, lockwasher (22) and pressure adjust potentiometer (22).
5. Remove seal (78) from potentiometer (22).

### Installation

1. Install seal (33) on potentiometer (22).
2. Fig. 10. Install pressure adjust potentiometer (22), shaft nut, lockwasher (22) and potentiometer knob (13).
  - a. Turn potentiometer shaft (22) clockwise to internal stop. Assemble potentiometer knob (13) to strike pin on plate (50).
  - b. After adjustment of step a., tighten both set screws in knob 1/4 to 3/8 turn after contact with shaft.
3. Connect lead (D) to control board (147).
4. Install display/cover (12) with four screws (11).

# Pressure Control Repair

## Digital Display Messages



Relieve pressure before repair; page 6. No display does not mean that sprayer is not pressurized.

DISPLAY	SPRAYER OPERATION	INDICATION	ACTION
No Display	Sprayer may be pressurized.	Loss of power or display not connected	Check power source. Relieve pressure before repair or disassembly. Verify display is connected.
----	Sprayer may be pressurized.	Pressure less than 200 psi (14 bar, 1.4 MPa)	Increase pressure as needed
3000 psi 210 bar 21 MPa	Sprayer is pressurized. Power is applied. (Pressure varies with tip size and pressure control setting.)	Normal operation	Spray
E-02	Sprayer stops. Engine is running.	Exceeded pressure limit	Remove any filter clogs or flow obstructions. Make sure gun trigger is locked open if using AutoClean valve.
E-03	Sprayer stops. Engine is running.	Pressure transducer faulty, bad connection or broken wire.	Check transducer connections and wire. Replace transducer or control board, if necessary.
E-05	Sprayer stops. Engine is running.	High clutch current	<ol style="list-style-type: none"> <li>1. Check clutch 7-pin bulk-head connector. Clean contacts.</li> <li>2. Measure <math>1.7 \pm 0.2\Omega</math> across clutch field at 70°F</li> <li>3. Replace clutch field assembly</li> </ol>
E-06	Sprayer stops. Engine is running. Display alternates E=06.	High clutch temperature	<ol style="list-style-type: none"> <li>1. If clutch is new, let sprayer cool down and then restart</li> <li>2. Inspect clutch. Replace clutch if there is excessive wear.</li> <li>3. Remove pump pin, separate pinion housing from clutch housing. Rotate rotor clockwise to check for excessive drag.</li> </ol>
E-07	Sprayer stops. Engine is running.	Pressure greater than 2000 psi (138 bar, 14 MPa) while in Flush Timer Mode	<ol style="list-style-type: none"> <li>1. Flush paint from hose before operating Flush Timer Mode</li> <li>2. Verify AutoClean is activated and gun valve and prime valve are open</li> </ol>

### After a fault, follow these steps to restart sprayer:

1. Correct fault condition
2. Turn sprayer OFF
3. Turn sprayer ON

# Displacement Pump

## Removal

1. Flush pump.

2.  Relieve pressure; page 6.

3. Fig. 11. Cycle pump with piston rod (222) in its lowest position.

4. Fig. 11. Remove suction tube (73) and hose (167).

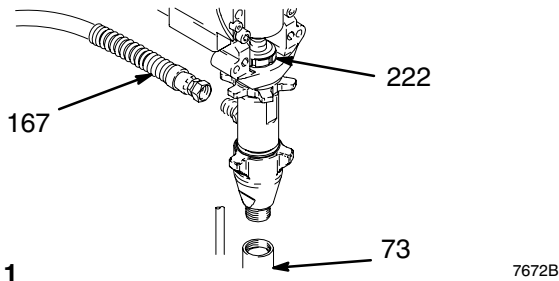

Fig. 11 7672B

5. Fig. 12. Use screwdriver: push retaining spring up and push out pin (58).

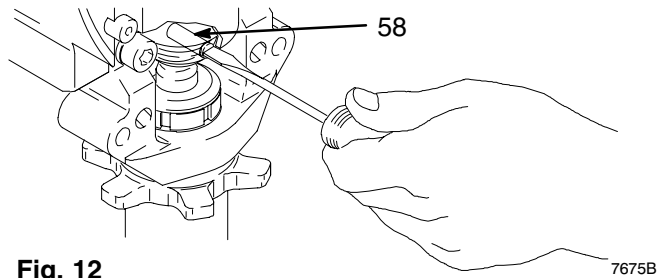

Fig. 12 7675B

6. Fig. 13. Loosen jam nut by hitting firmly with a 20 oz (maximum) hammer. Unscrew pump.

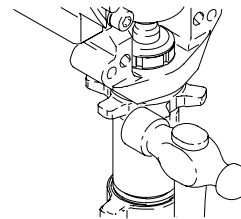

Fig. 13 7673B

## Repair

See manual 309277 for pump repair instructions.

## Installation

### WARNING

If pin works loose, parts could break off due to force of pumping action. Parts could project through the air and result in serious injury or property damage. Make sure pin and retaining spring are properly installed.

### CAUTION

If the pump jam nut loosens during operation, the threads of the bearing housing will be damaged. Make sure jam nut is properly tightened.

1. Fig. 14. Pull piston rod out 1.5 in. Screw in pump until holes in bearing cross link and piston rod align.

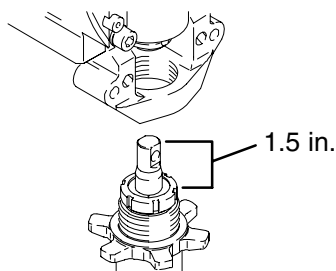

Fig. 14 7676B

2. Fig. 12. Push pin (19) into hole. And push retaining spring into groove all the way around connecting rod.

3. Fig. 15. Screw jam nut down onto pump until stops. Screw pump up into bearing housing until it is stopped by jam nut. Back off pump and jam nut to align pump outlet to back. Tighten jam nut by hand, then tap 1/8 to 1/4 turn with a 20 oz (maximum) hammer to approximately  $75 \pm 5$  ft-lb (102 N-m).

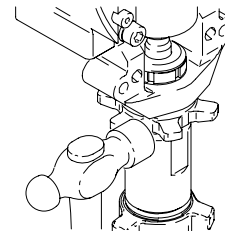

Fig. 15 7673B

4. Fig. 16. Fill packing nut with Graco TSL, through one of the slits, until fluid flows onto the top of seal.

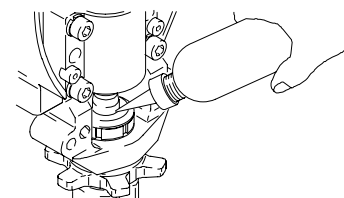

Fig. 16 7677B







# Parts – Basic Sprayer

Ref. No.	Part No.	Description	Qty.	Ref. No.	Part No.	Description	Qty.
3	245443	<b>HOUSING, drive</b> (5900)	1	76	206994	FLUID, TSL 8 oz bottle	1
4	245399	<b>HOUSING, pinion</b> (5900) parts, page 21	1	81	195119▲	LABEL, warning	1
5	245245	HANDLE, cart	1	82	195098	LABEL, instruction (English)	1
6	116806	SWITCH, reed	1	87	114271	STRAP, retaining	1
10	196670	LABEL, ctrl box cover, Ultra	1	88	108803	SCREW, hex, socket head	4
16	101682	SCREW, cap, sch	4	95	162485	NIPPLE, adapter	1
18	193682	PLUG, tube	2	97	183350	WASHER	2
19	106115	WASHER, lock spring (hi-collar)	4	99	108068	PIN, spring straight	2
20	114666	SCREW, cap, socket hd	4	100	198723	CLIP, axle	2
21	112798	SCREW, thread forming, hex hd	1	101	112406	SCREW, cap, hex hd	1
23	237686	CLAMP, grounding assy	1	102	245269	FRAME, cart, convert.	1
31	114686	SCREW, cap, socket hd	2	103	193547	BELT, vee, 30 in.	1
32	114794	CORD, power, convertible	1	105	192719	HANGER, pail	1
34	104008	WASHER, lock, spring	4	106	112746	NUT, hex	2
35	101864	SCREW, cap sch	4	107	114818	SCREW, self-tap, filhd	4
36	241440	GEAR, combination	1	110	198720	WHEEL, semi pneumatic, 12 in.	2
37	105510	WASHER, lock, spring hi-collar	15	115	114687	CLIP, retainer	2
38	241308	COVER, drive	1	117	198691	GUARD, belt	1
39		ROTOR, clutch, 5 in.; parts, page 24	1	120	108795	SCREW, mach, pnh	4
40	241279	ROD, connecting	1	121	114809	BUSHING, strain relief	1
47	100644	SCREW, cap, sch	4	123	191084	SLEEVE, cart	2
48	244224	<b>PUMP, displacement</b>	1	127	116891	WASHER	4
49	104811	CAP, hub	2	128	198772	COLLAR, torsion bar	2
53	198688	PULLEY, engine	1	137	198882	LABEL, ident, GMax 5900C	1
54	194125▲	LABEL, danger, English	1	139	112774	SCREW, MACH	9
57	193031	NUT, retaining	1	140	198904	SCREW, PLASTITE #8	2
58	183210	PIN, str, hdls	1	141	109575	SCREW, threadforming, hex hd	3
59	183169	SPRING, retaining	1	142	245688	BAR, torsion, includes 128	1
60	241015	<b>HOUSING, bearing</b>	1	151	198697	BRACKET, shelf belt guard	1
61	114699	WASHER, thrust	1	152	110997	SCREW, flange, hex	3
62	114672	WASHER, thrust	2	162	109032	SCREW, mach, pnh	2
63	112395	SCREW, cap, flnghd	3	166	112717	WASHER	2
64	290228	LABEL, CAUTION	1	167	243814	HOSE, coupled	1
66	109099	BUSHING, snap	1	169	245689	HOUSING, clutch	1
70	181072	STRAINER, inlet	1	171	198996	BRACKET, belt guide	1
71	241920	DEFLECTOR, threaded	1	175	111590	BUTTON, snap	2
72	197124	CLIP, spring	1	179	155699	ELBOW, street	1
73	193097	TUBE, suction	1	185	100002	SCREW, set, sch	2
74	244240	HOSE, coupled	1	188	100078	SCREW, mach, slit hex wash hd	4
				189	245406	SHAFT, input; part of Kit 169	1

# Engine Detail

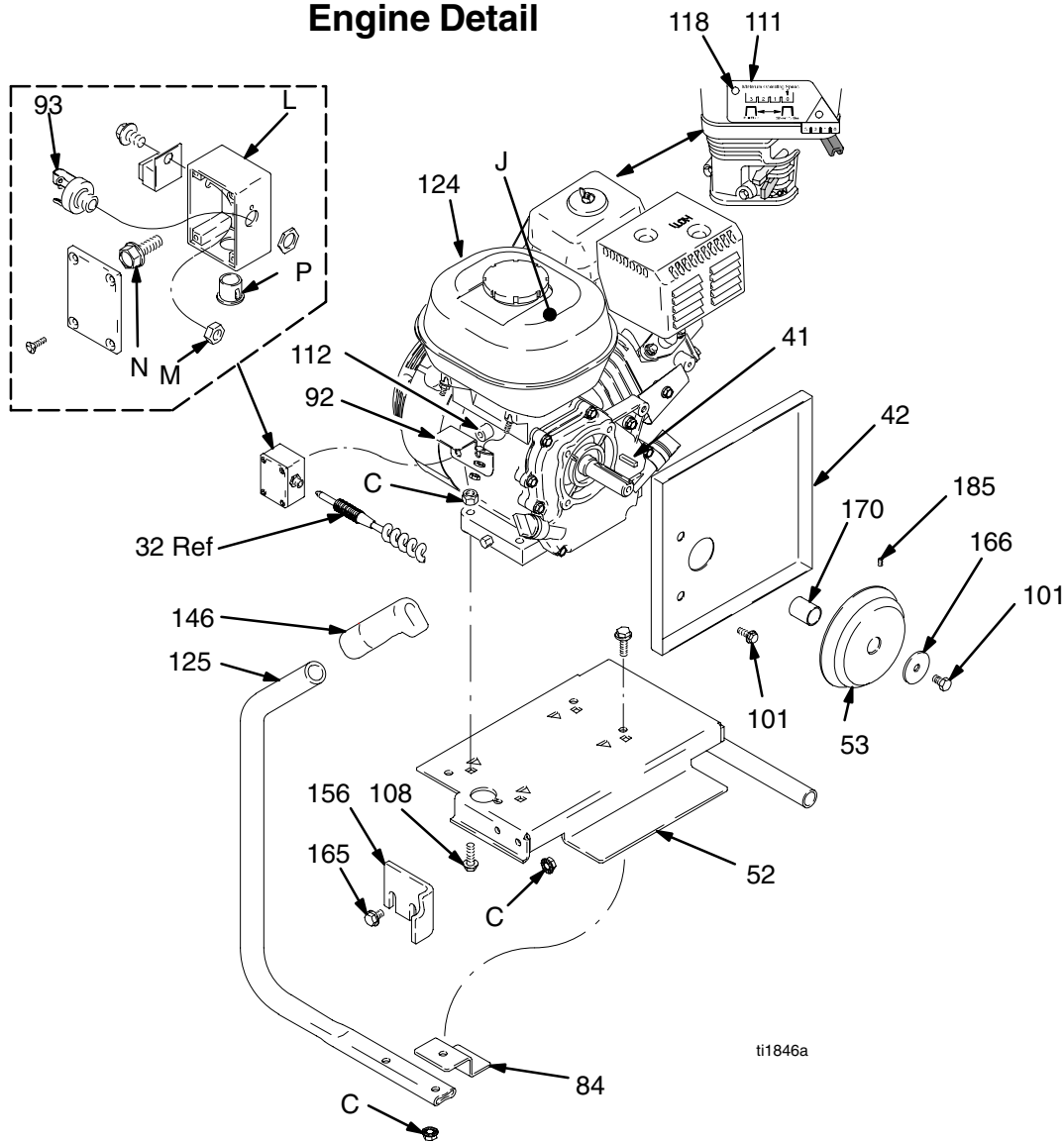

ti1846a

Ref. No.	Part No.	Description	Qty.	Ref. No.	Part No.	Description	Qty.
41	183401	KEY, parallel	1	125	198693	HANDLE, slide, engine	2
42	198689	BRACKET, belt guard (motor)	2	146	116139	GRIP, handle	2
52	245272	BASE, mounting	1	156	198695	BRACKET, torsion bar	1
53	198688	PULLEY, engine	1	165	111800	SCREW, cap, hex hd, flange	2
84	194925	BRACKET, tension	1	166	112717	WASHER	2
92	194414	BRACKET, J-box	13	170	198995	SLEEVE, motor shaft	1
93	114805	JACK, 1/4 engine	1	185	100002	SCREW, set, sch	2
101	112406	SCREW, cap, hex hd	3	C	110996	NUT, flng hd, hex	6
108	114653	SCREW, cap, flange hd	4	J▲	194126	LABEL, warning	1
111	192014	PLATE, indicator	1	L	194181	BOX, junction, engine	1
112	116149	SPACER	1	M	114816	NUT, hex	1
118	113084	RIVET, blind	2	N	114813	SCREW, mach, hex washer hd	1
124	114530	ENGINE, gas, 5.5HP, Honda	1	P	109099	BUSHING, snap	1

# Parts List & Drawing – Pinion Assembly

## Ref No. 4 and 3

### Ref No. 4: Pinion Housing Assembly 245399

Ref No.	Part No.	Description	Qty
4a	245267	PINION HOUSING & COIL	1
4b	105489	PIN	2
4d*		PINION SHAFT	1
4e*	112770	RETAINING RING, large	1

\*Must be ordered separately

### Ref No. 3: Drive Housing Assembly 245443

Ref No.	Part No.	Description	Qty
3		HOUSING, drive	1
3g*	194173	WASHER	1
3h*	116192	WASHER	1
3k	116806	SWITCH, reed	1
3m	116838	PIN, spring	2
3n	116618	MAGNET	1
3p	15A622	LABEL, WatchDog	1

\*Must be ordered separately

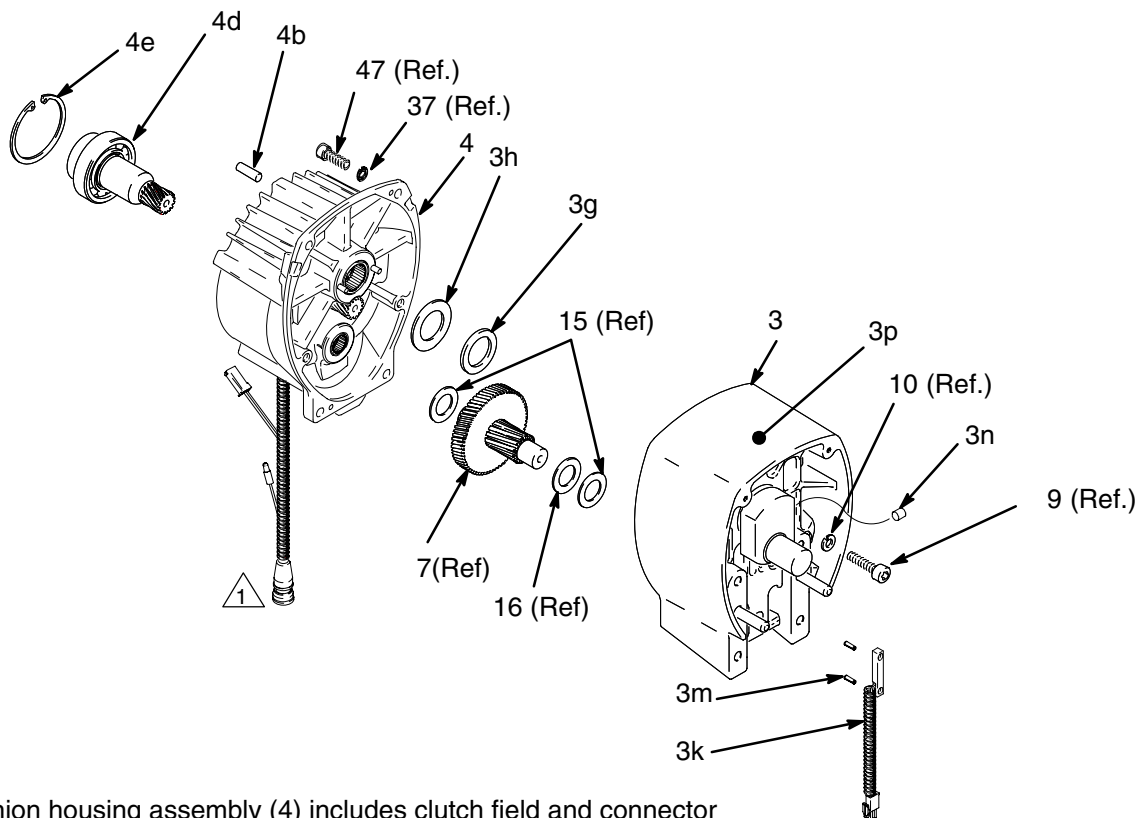

1 Pinion housing assembly (4) includes clutch field and connector

TI0177B

# Parts Drawing – Sprayer

Ref No 24

Pressure Control Assembly

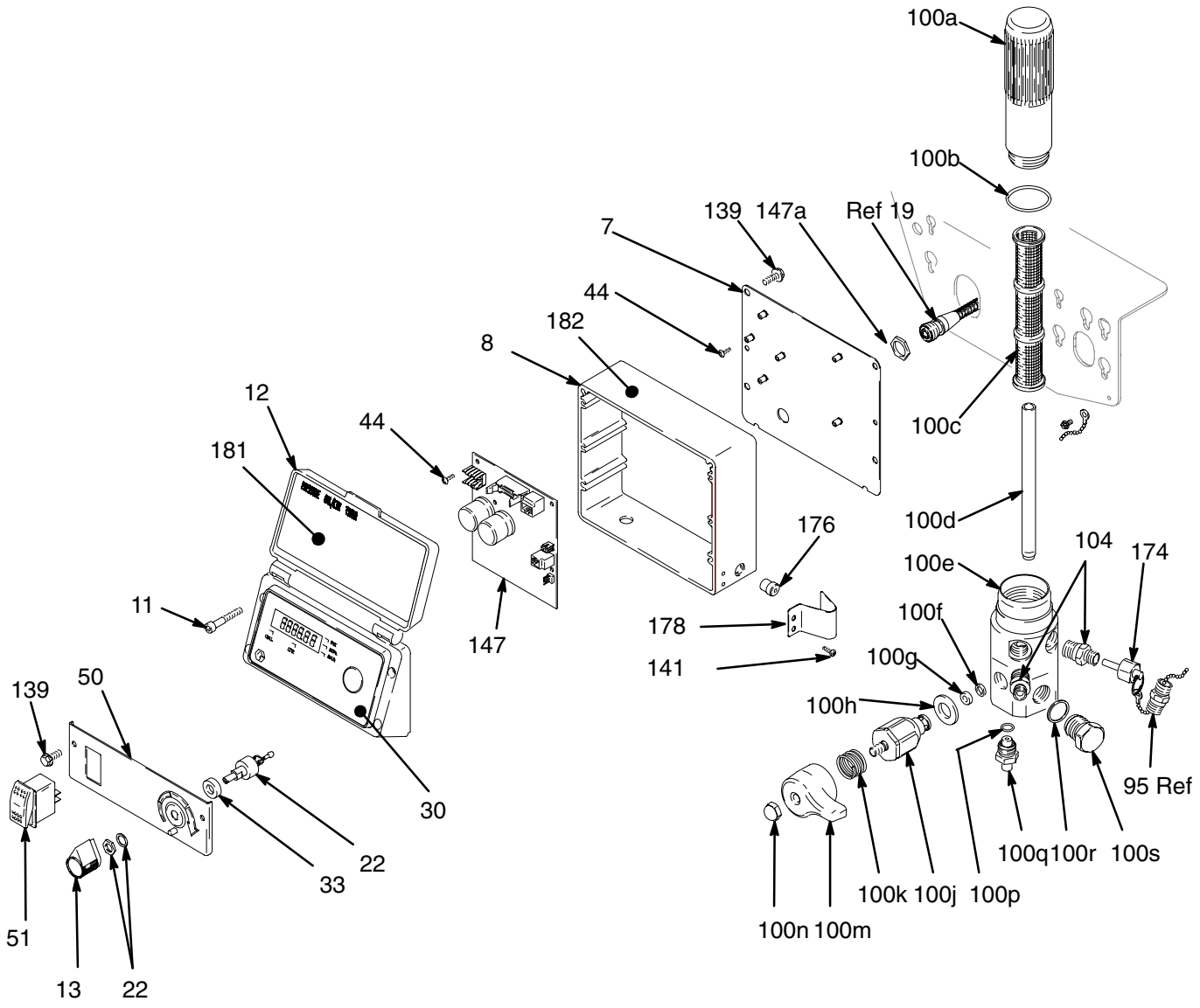

ti1848a

# Parts List – Sprayer

REF NO.	PART NO.	DESCRIPTION	QTY	REF NO.	PART NO.	DESCRIPTION	QTY
7	198534	PLATE, control	1				
8	198548	HOUSING, control	1	100	245396	FILTER, fluid	1
11	116252	SCREW, #8 taptite, phil	4	100a	196675	KIT, repair, filter	1
12	245393	COVER, digital display	1	100b	104361	BOWL, filter	1
		Includes 11, 30, 181,		100c	244067	O-RING	1
13	116167	KNOB, potentiometer	1	100d	196786	STRAINER, mesh, 60	1
22	241443	POTENTIOMETER, pressure control	1	100e	245401	TUBE, diffuser	1
30	198648	LABEL, GMax, LCD	1	100f	193710	KIT, repair, filter base	1
33	198650	SPACER, shaft	1	100g	193709	SEAL, valve	1
44	114331	SCREW, pnhd 6-32	6	100h	114797	SEAT, valve	1
50	198553	PANEL, control	1	100i	245103*	GASKET	1
51	116752	SWITCH, rocker, (spst)	1	100j	245103*	VALVE	1
95	162485	NIPPLE, adapter	1	100k	114708	SPRING, compression	1
104	164672	ADAPTER	2	100l	194102	HANDLE, valve	1
139	112774	SCREW, mach	4	100m	114688	TRANSDUCER, pressure control	1
141	109575	SCREW, threadforming, hex hd	4	100n	114688	includes 100p	1
147	245394	BOARD, PC	1	100o	197055	NUT, cap, hex hd	1
		Includes 147a		100p	111457	O-RING	1
147a		NUT, nylon	1	100q	243222	PLUG, AutoClean	1
174	245474	PLUG, packless	1				
176	114296	BUSHING, step	1				
178	198994	GUARD, transducer	1				
181	198884	LABEL, instruction, GMax	1				
182▲	189246	LABEL, warning	1				

\* Drain valve repair kit 245103 includes 100f, g, h, k, m, n  
 ▲ Replacement warning labels may be ordered free of charge

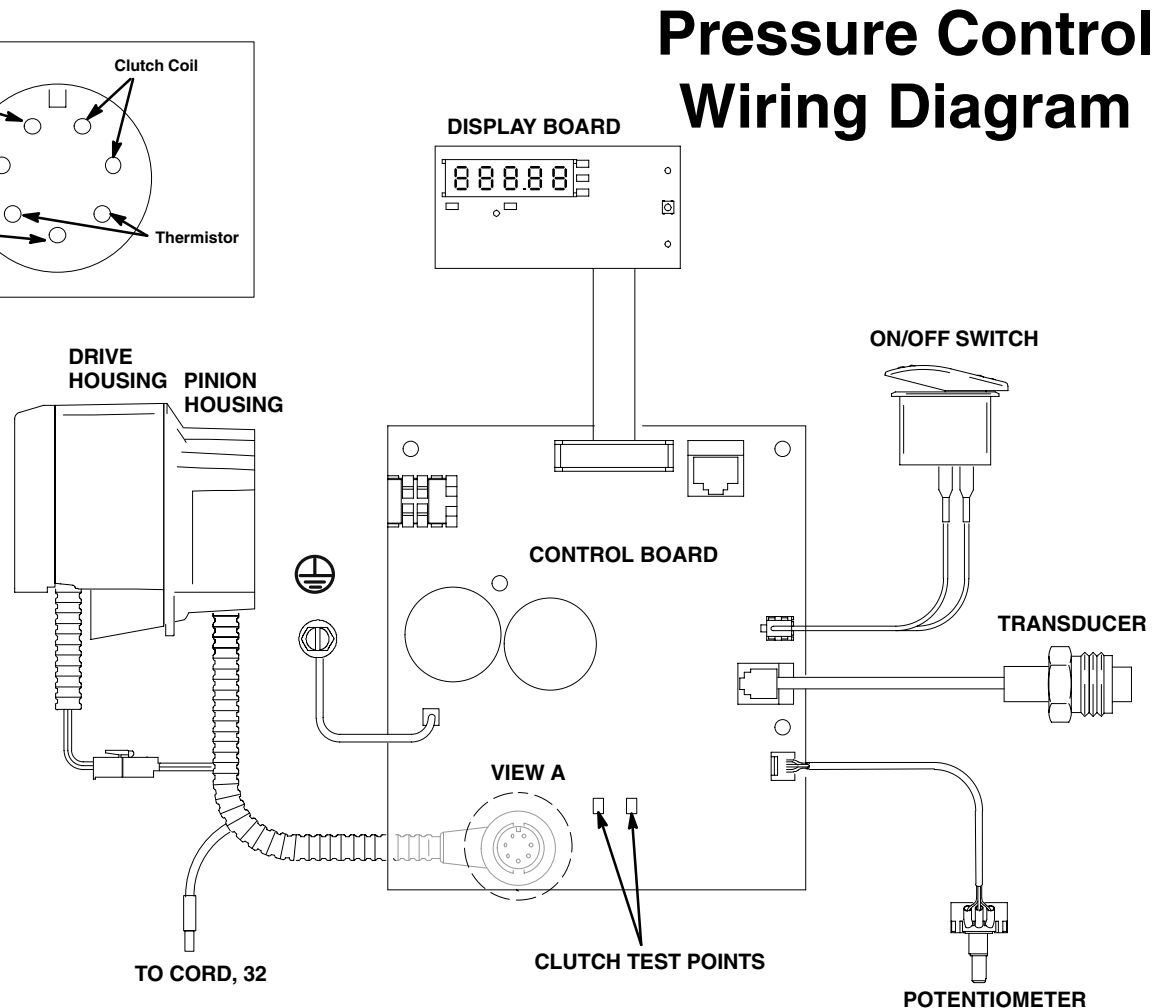
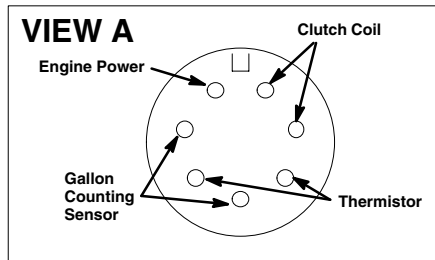
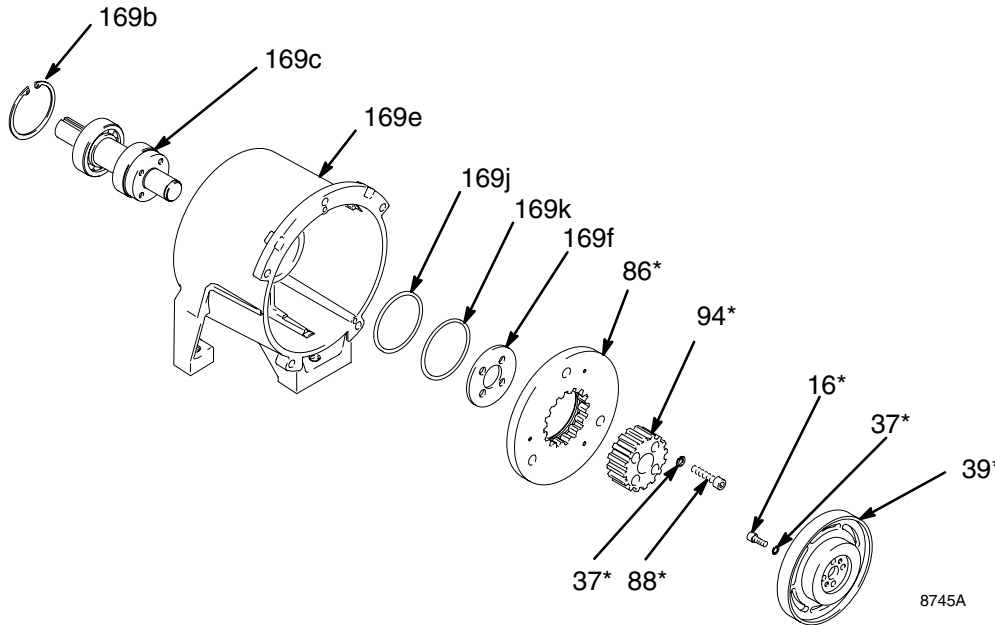

Fig. 17

ti1843a

# Parts List & Drawing –Clutch Assembly

Ref No.	Part No.	Description	Qty	Ref No.	Part No.	Description	Qty
16*	101682	SCREW, cap, sch	4	169b	114962	RING, retaining, internal	1
37*	105510	WASHER, lock, spring	8	169c	245406	SHAFT, drive, input	1
39*		ROTOR, clutch, 5 in.	1	169e	193493	HOUSING, clutch	1
86*		ARMATURE, clutch	1	169f	194059	STOP, armature	1
88*	108803	SCREW, hex, sch	4	169j	115078	O-RING	1
94*		HUB, armature	1	169k	115079	O-RING	1
169	245689	HOUSING, clutch Includes 169b, 169c, 169e, 169j & 169k	1	* Clutch replacement kit 241113 includes 16, 37, 39, 86, 88, and 94			



## Parts – Complete Sprayer

### Model 233710, 233714

Includes:

- 233709 Convertible GMax 5900C Sprayer, parts list page 18,
- 245507 (233714) Lo-Boy Suction Set Kit, parts list page 25
- 287036 Contractor Gun Kit below:

Ref. No.	Part No.	Description	Qty.
226	287036	<b>Contractor II Gun Kit</b> Includes 226a – 226c	1
226a	240794	HOSE, grounded, nylon; 1/4" ID; cpld 1/4 npsm(fbe); 50 ft (15 m); spring guards both ends	1
226b	238358	HOSE, grounded, nylon; 3/16" ID; cpld 1/4 npsm(m) x 1/4 npsm(f) swivel; 3 ft (0.9 m); spring guards both ends	1
226c	246220	<b>CONTRACTOR II SPRAY GUN</b> Includes RAC X HandTite™ Tip Guard and 517 SwitchTip™ See 309639 for parts	1

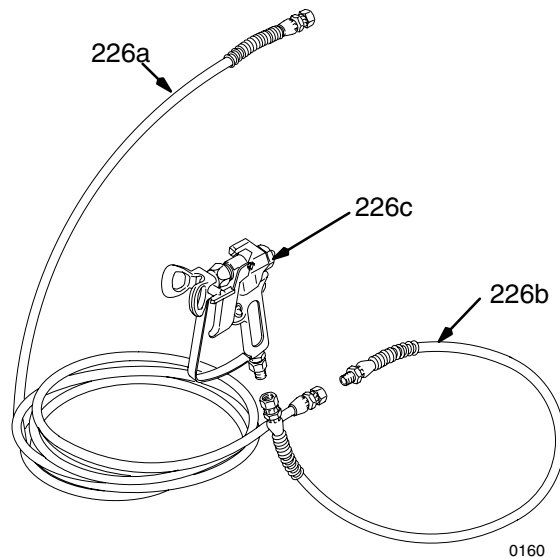



# Parts – Lo-Boy Suction Set Kit

## Model 245507

Includes items 401 to 407

Ref. No.	Part No.	Description	Qty.
401	241124	.TUBE, suction, 5 gallon (20 liter) includes 401a through 401e	1
401a	240513	..SWIVEL, tube, inlet	1
401b	176450	..GUARD, hose	1
401c	194306	..HOSE, fluid	1
401d	101818	..CLAMP, hose	2
401e	170957	..TUBE, suction	1
402	245611	..HOSE, drain, includes 406	1
403	194194	..CLIP, spring	1
405	181072	..STRAINER	1
406	241920	..DEFLECTOR	1
407	144958	..STRAP, tie	1

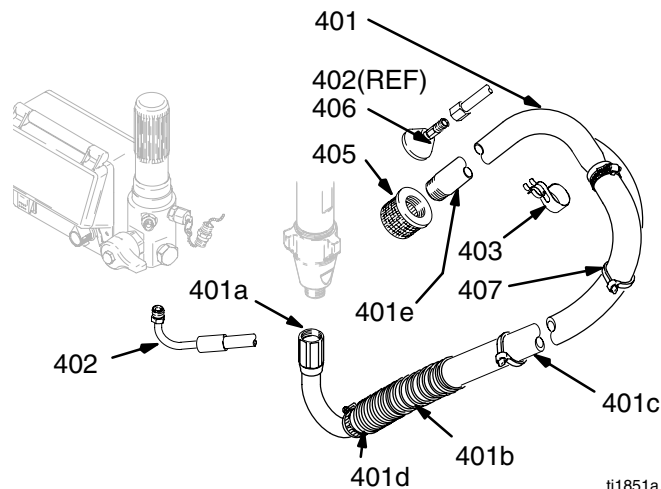

## Technical Data

Honda GX160 Engine

Power Rating @ 3700 rpm

ANSI ..... 5.5 Horsepower

DIN 6270B/DIN 6271

NA ..... 2.9 Kw – 4.0 Ps

NB ..... 3.6 Kw – 4.9 Ps

Maximum Working Pressure ..... 3300 psi  
(227 bar, 22.7 MPa)

Cycles/Gallon (liter) ..... 93 (25)

Maximum Delivery ..... 1.25 gpm (4.7 liter/min)

Fuel Tank Capacity ..... 0.95 gallons (3.6 liter)

Maximum Tip Size ..... 1 gun with 0.041 tip  
2 guns with 0.028 tip

Inlet Paint Strainer ..... 16 mesh (1190 micron)  
Stainless steel screen, reusable

Outlet Paint Filter ..... 60 mesh (250 micron)  
Stainless steel screen, reusable

Pump inlet Size ..... 3/4 npt (m)

Fluid Outlet Size ..... 1/4 npsm from fluid filter

Wetted parts ..... zinc-plated carbon steel,  
PTFE, Nylon, polyurethane, UHMW polyethylene,  
Viton®, Delrin®, leather, aluminum, tungsten car-  
bide, nickel-plated carbon steel, stainless steel,  
chrome plating

**NOTE:** Delrin®, Viton® are trademarks of the DuPont Company.

## Dimensions

### Model 233709

Weight (dry, without packaging) ..... 170 lb (77 kg)

Height ..... 41 in. (104.1 cm)

Length ..... 39 in. (99.1 cm)

Width ..... 22 in. (55.9 cm)

### DANGER LABELS

The English language DANGER label is on your sprayer. If you have painters who do not read English, order one of the following labels to apply to your sprayer. The drawing below shows the best placement of these labels for good visibility.

Order the labels directly from your Graco distributor.

**French** 194931  
**Spanish** 194932  
**German** 194933  
**Greek** 194934  
**Korean** 194935  
**English** 194125

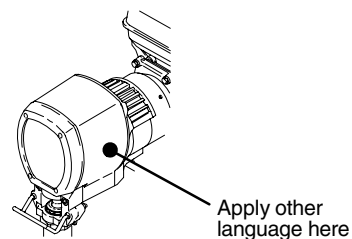

03497A

# Graco Standard Warranty

Graco warrants all equipment manufactured by Graco and bearing its name to be free from defects in material and workmanship on the date of sale by an authorized Graco distributor to the original purchaser for use. With the exception of any special, extended, or limited warranty published by Graco, Graco will, for a period of twelve months from the date of sale, repair or replace any part of the equipment determined by Graco to be defective. This warranty applies only when the equipment is installed, operated and maintained in accordance with Graco's written recommendations.

This warranty does not cover, and Graco shall not be liable for general wear and tear, or any malfunction, damage or wear caused by faulty installation, misapplication, abrasion, corrosion, inadequate or improper maintenance, negligence, accident, tampering, or substitution of non-Graco component parts. Nor shall Graco be liable for malfunction, damage or wear caused by the incompatibility of Graco equipment with structures, accessories, equipment or materials not supplied by Graco, or the improper design, manufacture, installation, operation or maintenance of structures, accessories, equipment or materials not supplied by Graco.

This warranty is conditioned upon the prepaid return of the equipment claimed to be defective to an authorized Graco distributor for verification of the claimed defect. If the claimed defect is verified, Graco will repair or replace free of charge any defective parts. The equipment will be returned to the original purchaser transportation prepaid. If inspection of the equipment does not disclose any defect in material or workmanship, repairs will be made at a reasonable charge, which charges may include the costs of parts, labor, and transportation.

**THIS WARRANTY IS EXCLUSIVE, AND IS IN LIEU OF ANY OTHER WARRANTIES, EXPRESS OR IMPLIED, INCLUDING BUT NOT LIMITED TO WARRANTY OF MERCHANTABILITY OR WARRANTY OF FITNESS FOR A PARTICULAR PURPOSE.**

Graco's sole obligation and buyer's sole remedy for any breach of warranty shall be as set forth above. The buyer agrees that no other remedy (including, but not limited to, incidental or consequential damages for lost profits, lost sales, injury to person or property, or any other incidental or consequential loss) shall be available. Any action for breach of warranty must be brought within two (2) years of the date of sale.

Graco makes no warranty, and disclaims all implied warranties of merchantability and fitness for a particular purpose in connection with accessories, equipment, materials or components sold but not manufactured by Graco. These items sold, but not manufactured by Graco (such as electric motors, switches, hose, etc.), are subject to the warranty, if any, of their manufacturer. Graco will provide purchaser with reasonable assistance in making any claim for breach of these warranties.

In no event will Graco be liable for indirect, incidental, special or consequential damages resulting from Graco supplying equipment hereunder, or the furnishing, performance, or use of any products or other goods sold hereto, whether due to a breach of contract, breach of warranty, the negligence of Graco, or otherwise.

## **FOR GRACO CANADA CUSTOMERS**

The parties acknowledge that they have required that the present document, as well as all documents, notices and legal proceedings entered into, given or instituted pursuant hereto or relating directly or indirectly hereto, be drawn up in English. Les parties reconnaissent avoir convenu que la rédaction du présente document sera en Anglais, ainsi que tous documents, avis et procédures judiciaires exécutés, donnés ou intentés à la suite de ou en rapport, directement ou indirectement, avec les procédures concernées.

**TO PLACE AN ORDER OR FOR SERVICE**, contact your Graco distributor, or call this number to identify the distributor near you: **1-800-690-2894 Toll Free**

*All written and visual data contained in this document reflects latest product information available at time of publication. Graco reserves right to make changes at any time without notice.*

MM 309411

**Graco Headquarters:** Minneapolis  
**International Offices:** Belgium, China, Japan, Korea  
**GRACO INC. P.O. BOX 1441 MINNEAPOLIS, MN 55440-1441**

**www.graco.com**

Printed in USA 309411

1/2002 Rev. 7/2005