

Merkur™ Pump

309462 rev.G



Important Safety Instructions

Read all warnings and instructions in this manual.
Save these instructions.

See page 3 for model information.

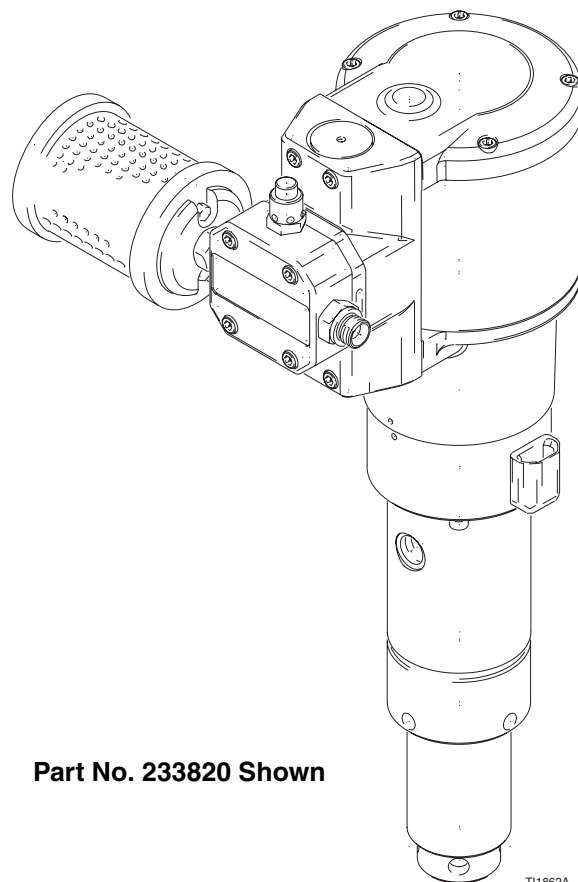

Part No. 233820 Shown

T11862A

PROVEN QUALITY. LEADING TECHNOLOGY.

Contents

- Manual Conventions** 2
- Model Information** 3
 - Complete Pumps 3
 - ECOMIX Displacement Pumps 3
- Warning** 4
- Installation** 6
 - General Information 6
 - Grounding 6
 - Mounting Accessories 6
 - Install the Muffler 7
 - Air Inlet Fitting 7
 - Air and Fluid Hoses 7
 - Air Line Accessories 7
 - Fluid Inlet Adapter 7
 - Fluid Line Accessories 7
- Operation** 9
 - Pressure Relief Procedure 9
 - Flush the Pump Before First Use 9
 - Starting and Adjusting the Pump 10
 - Shutdown and Care of the Pump 10
 - Flush the Equipment 11
- Maintenance** 12
 - Preventive Maintenance Schedule 12
 - Storage 12
 - Tightening Threaded Connections 12
 - Cleaning 12
 - Wet-Cup 12
- Troubleshooting** 13

- Repair** 15
 - Tools Required 15
 - Disconnect the Motor from the Displacement Pump 15
 - Reconnect the Motor to the Displacement Pump 15
 - Air Valve Repair 16
 - Air Motor Piston and Cylinder Repair 17
 - Displacement Pump Repair 19
- Parts** 23
 - Complete Pump 23
 - D110 and D160 Air Motors 25
 - Air Motor Repair Kits 26
 - 020, 035, and 050 Displacement Pumps 27
 - Displacement Pump Repair Kits 30
 - ECOMIX Displacement Pumps 31
- Technical Data** 34
- Performance Charts** 35
 - Part Nos. 233752 and 233818, 15:1 Ratio, 50 cc (1.7 oz) per stroke 35
 - Part Nos. 233753 and 233819, 20:1 Ratio, 35 cc (1.2 oz) per stroke 35
 - Part Nos. 233754 and 233820, 30:1 Ratio, 20 cc (0.7 oz) per stroke 36
 - Part Nos. 233755 and 233821, 30:1 Ratio, 50 cc (1.7 oz) per stroke 36
 - Part Nos. 233756 and 233822, 40:1 Ratio, 35 cc (1.2 oz) per stroke 37
- Dimensions** 38
- Graco Warranty** 40
- Graco Phone Numbers** 40

Manual Conventions

Warning

WARNING

A warning alerts you to the possibility of serious injury or death if you do not follow the instructions.

Symbols, such as fire and explosion (shown above), alert you to a specific hazard and direct you to read the indicated hazard warnings (pages 4-5) for detailed information.

Caution

CAUTION

A caution alerts you to the possibility of damage to or destruction of equipment if you do not follow the instructions.

Note

A note calls attention to additional helpful information.

Model Information

Complete Pumps

Pump Part No.	Series	Pump Ratio	Pump Model (see key below)	Air Motor Part No. diameter mm (in.)	Displacement Pump Part No. Volume per Stroke	Maximum Air Input Pressure MPa, bar (psi)	Maximum Fluid Working Pressure MPa, bar (psi)
233752	A	15:1	015.050 BSPP	245354 D110 (4.33)	245352 050 cc (1.7 oz)	0.7, 7 (100)	10.5, 105 (1500)
233753	A	20:1	020.035 BSPP	245354 D110 (4.33)	245353 035 cc (1.2 oz)	0.7, 7 (100)	14.0, 140 (2000)
233754	A	30:1	030.020 BSPP	245354 D110 (4.33)	245351 020 cc (0.7 oz)	0.7, 7 (100)	21.0, 210 (3000)
233755	A	30:1	030.050 BSPP	245355 D160 (6.30)	245352 050 cc (1.7 oz)	0.7, 7 (100)	21.0, 210 (3000)
233756	A	40:1	040.035 BSPP	245355 D160 (6.30)	245353 035 cc (1.2 oz)	0.7, 7 (100)	28.0, 280 (4000)
233818	A	15:1	015.050 NPT	245354 D110 (4.33)	245352 050 cc (1.7 oz)	0.7, 7 (100)	10.5, 105 (1500)
233819	A	20:1	020.035 NPT	245354 D110 (4.33)	245353 035 cc (1.2 oz)	0.7, 7 (100)	14.0, 140 (2000)
233820	A	30:1	030.020 NPT	245354 D110 (4.33)	245351 020 cc (0.7 oz)	0.7, 7 (100)	21.0, 210 (3000)
233821	A	30:1	030.050 NPT	245355 D160 (6.30)	245352 050 cc (1.7 oz)	0.7, 7 (100)	21.0, 210 (3000)
233822	A	40:1	040.035 NPT	245355 D160 (6.30)	245353 035 cc (1.2 oz)	0.7, 7 (100)	28.0, 280 (4000)

Key to Pump Model Designation

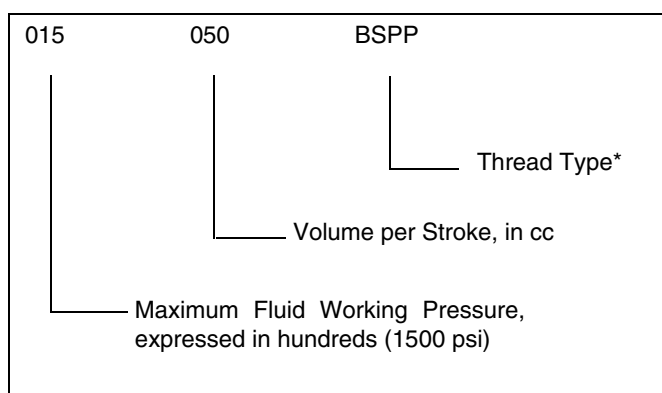

* BSPP stands for British Standard Pipe Parallel Thread; npt stands for National Pipe Taper Thread.

ECOMIX Displacement Pumps

Optional displacement pumps with leather and PTFE throat packings, UHMWPE and PTFE piston packings. Available as displacement pumps only.

Displacement Pump Part No.	Series	Displacement Pump Volume per Stroke
245641	A	050 cc (1.7 oz)
245640	A	035 cc (1.2 oz)
245639	A	020 cc (0.7 oz)

Warning
**EQUIPMENT MISUSE HAZARD**

Equipment misuse can cause the equipment to rupture or malfunction and result in serious injury.

- This equipment is for professional use only.
- Read all instruction manuals, tags, and labels before operating the equipment.
- Use the equipment only for its intended purpose. If you are not sure, call your Graco distributor.
- Do not alter or modify this equipment. Use only genuine Graco parts and accessories.
- Check equipment daily. Repair or replace worn or damaged parts immediately.
- Do not exceed the maximum working pressure of the lowest rated system component. Refer to the **Technical Data** on page 35 for the maximum working pressure of this equipment.
- Use fluids and solvents which are compatible with the equipment wetted parts. Refer to the Technical Data section of all equipment manuals. Read the fluid and solvent manufacturer's warnings.
- Do not use hoses to pull equipment.
- Route hoses away from traffic areas, sharp edges, moving parts, and hot surfaces. Do not expose Graco hoses to temperatures above 82°C (180°F) or below -40°C (-40°F).
- Wear hearing protection when operating this equipment.
- Comply with all applicable local, state, and national fire, electrical, and safety regulations.

**SKIN INJECTION HAZARD**

Spray from the gun, leaks or ruptured components can inject fluid into your body and cause extremely serious injury, including the need for amputation. Fluid splashed in the eyes or on the skin can also cause serious injury.

- Fluid injected into the skin might look like just a cut, but it is a serious injury. **Get immediate surgical treatment.**
- Do not point the gun at anyone or at any part of the body.
- Do not put your hand or fingers over the spray tip.
- Do not stop or deflect leaks with your hand, body, glove or rag.
- Do not "blow back" fluid; this is not an air spray system.
- Always have the tip guard and the trigger guard on the gun when spraying.
- Check the gun diffuser operation weekly. Refer to the gun manual.
- Be sure the gun trigger safety operates before spraying.
- Lock the gun trigger safety when you stop spraying.
- Follow the **Pressure Relief Procedure** on page 9 if the spray tip clogs and before cleaning, checking or servicing the equipment.
- Tighten all fluid connections before operating the equipment.
- Check the hoses, tubes, and couplings daily. Replace worn or damaged parts immediately.
- Do not repair high pressure couplings; you must replace the entire hose.

Warning
**FIRE AND EXPLOSION HAZARD**

Improper grounding, poor ventilation, open flames or sparks can cause a hazardous condition and result in a fire or explosion and serious injury.

- Ground the equipment and the object being sprayed. Refer to **Grounding** on page 6.
- If there is any static sparking or you feel an electric shock while using this equipment, stop spraying immediately. Do not use the equipment until you identify and correct the problem.
- Provide fresh air ventilation to avoid the buildup of flammable fumes from solvents or the fluid being sprayed.
- Keep the spray area free of debris, including solvent, rags, and gasoline.
- Electrically disconnect all equipment in the spray area.
- Extinguish all open flames or pilot lights in the spray area.
- Do not smoke in the spray area.
- Do not turn on or off any light switch in the spray area while operating or if fumes are present.
- Do not operate a gasoline engine in the spray area.

**TOXIC FLUID HAZARD**

Hazardous fluid or toxic fumes can cause serious injury or death if splashed in the eyes or on the skin, inhaled, or swallowed.

- Know the specific hazards of the fluid you are using.
- Store hazardous fluid in an approved container. Dispose of hazardous fluid according to all local, state and national guidelines.
- Always wear protective eyewear, gloves, clothing and respirator as recommended by the fluid and solvent manufacturer.

Installation



General Information

-  Reference numbers and letters in parentheses in the text refer to the callouts in the figures and the parts drawing.
- Always use Genuine Graco Parts and Accessories, available from your Graco distributor. If you supply your own accessories, be sure they are adequately sized and pressure-rated for your system.
- FIG. 2 is a guide for selecting and installing system components and accessories. It is not an actual system design. Contact your Graco distributor for assistance in designing a system to suit your particular needs.

2. *Air and fluid hoses:* use only electrically conductive hoses.
3. *Air compressor:* follow manufacturer's recommendations.
4. *Spray gun:* ground through connection to a properly grounded fluid hose and pump.
5. *Fluid supply container:* follow your local code.
6. *Object being sprayed:* follow your local code.
7. *Solvent pails used when flushing:* follow your local code. Use only metal pails, which are conductive, placed on a grounded surface. Do not place the pail on a nonconductive surface, such as paper or cardboard, which interrupts the grounding continuity.

Grounding

 **WARNING**

Before operating the pump, ground the system as explained below. Read the warnings on page 5.

1. *Pump:* use a ground wire and clamp. See FIG. 1. Insert one end of a 1.5 mm³ (12 ga) minimum ground wire (Y) into the pump's grounding clamp (16) and tighten the screw (W) securely. Connect the other end of the wire to a true earth ground. Order Part No. 238909 Ground Wire.

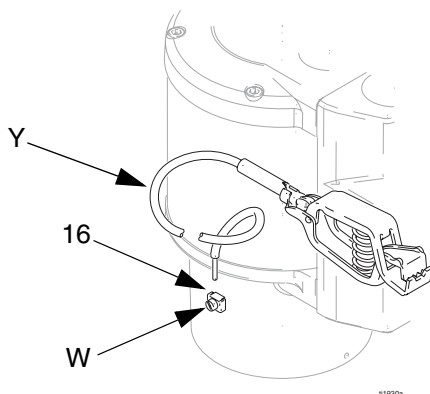
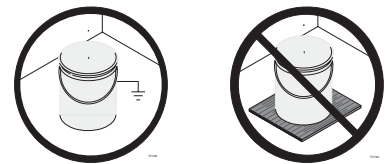
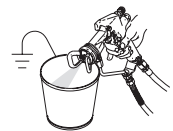

FIG. 1. Grounding Wire



8. *To maintain grounding continuity when flushing or relieving pressure,* hold a metal part of the spray gun firmly to the side of a grounded *metal* pail, then trigger the gun.



Mounting Accessories

Mount the pump (E) to suit the type of installation planned. FIG. 2 illustrates a wall mount system. Pump dimensions are shown on page 39.

To assemble and install a package, refer to the separate instructions included with the package.

1. Be sure the mounting surface can support the weight of the pump, bracket, hoses and accessories, as well as the stress caused during operation.
2. Position the wall bracket about 1.2-1.5 m (4-5 ft) above the floor. For ease of operation and service, make sure the pump air inlet, fluid inlet, and fluid outlet are easily accessible.

- Drill mounting holes in the wall. Attach the bracket to the wall. Use screws that are long enough to keep the pump from vibrating during operation. Be sure the bracket is level.

Install the Muffler

The muffler (C) is shipped loose. Screw the muffler into the muffler port before installing the pump.

Air Inlet Fitting

The 1/4 npt air inlet fitting (110) is supplied on Models 233818 through 233822. It is held in place with a setscrew (33). Loosen the setscrew before removing the fitting. Tighten the setscrew to hold the fitting in place.



A 3/8 bspp(m) air inlet fitting is available as an accessory for Models 233752 through 233756. Order Part No. 245682.

Air and Fluid Hoses

Be sure all air hoses (A, P) and fluid hoses (R, U) are properly sized and pressure-rated for your system. Use only electrically conductive fluid hoses. Fluid hoses must have spring guards on both ends. Use a swivel (S) between the fluid hose (R) and the gun (T) to allow easier gun movement.

Air Line Accessories

Install the following accessories in the order shown in FIG. 2, using adapters as necessary:

- A bleed-type master air valve (B) is required in your system to relieve air trapped between it and the air motor when the valve is closed. Be sure the bleed valve is easily accessible from the pump.
- A pump air regulator (D) controls pump speed and outlet pressure by adjusting the air pressure to the pump. Locate the regulator close to the pump.
- A gun air regulator (N) controls air pressure to the air-assisted spray gun.
- An air line filter (M) removes harmful dirt and moisture from the compressed air supply.
- A second bleed-type air valve (L) isolates the air line accessories for servicing. Locate upstream from all other air line accessories.

Fluid Inlet Adapter

The npt fluid inlet adapter (109) is supplied on Models 233818 through 233822 only. It includes a sealing o-ring (109a). Be sure the o-ring is in place before installing the fitting. Screw the fitting into the pump a minimum of two full turns, until it faces the desired direction. It is not necessary to fully engage the threads. Do not over-tighten.

When using (51), fluid cup kit 245717, or suction tube kits 245724 and 245737, elbow 233888 must be used in place of supplied npt adapter. Assemble fitting per above instructions. Connect accessory kit to fitting by inserting tube until fully seated. To secure tube, tighten the compression nut on the fitting.

Fluid Line Accessories

Install the following accessories in the positions shown in FIG. 2, using adapters as necessary:

- A fluid filter (F) with a 60 mesh (250 micron) stainless steel element, to filter particles from the fluid as it leaves the pump. Install a fluid drain valve (G), which is required in your system to relieve fluid pressure in the hose and gun.
- A fluid shutoff valve (H) shuts off fluid flow.
- A fluid pressure regulator (J) allows more precise adjustment of the fluid pressure.
- A gun or valve (T) dispenses the fluid. The gun shown in FIG. 2 is an air-assisted spray gun for light to medium viscosity fluids.
- A fluid line swivel (S) allows easier gun movement.
- A suction kit (K) allows the pump to draw fluid from a fluid container.

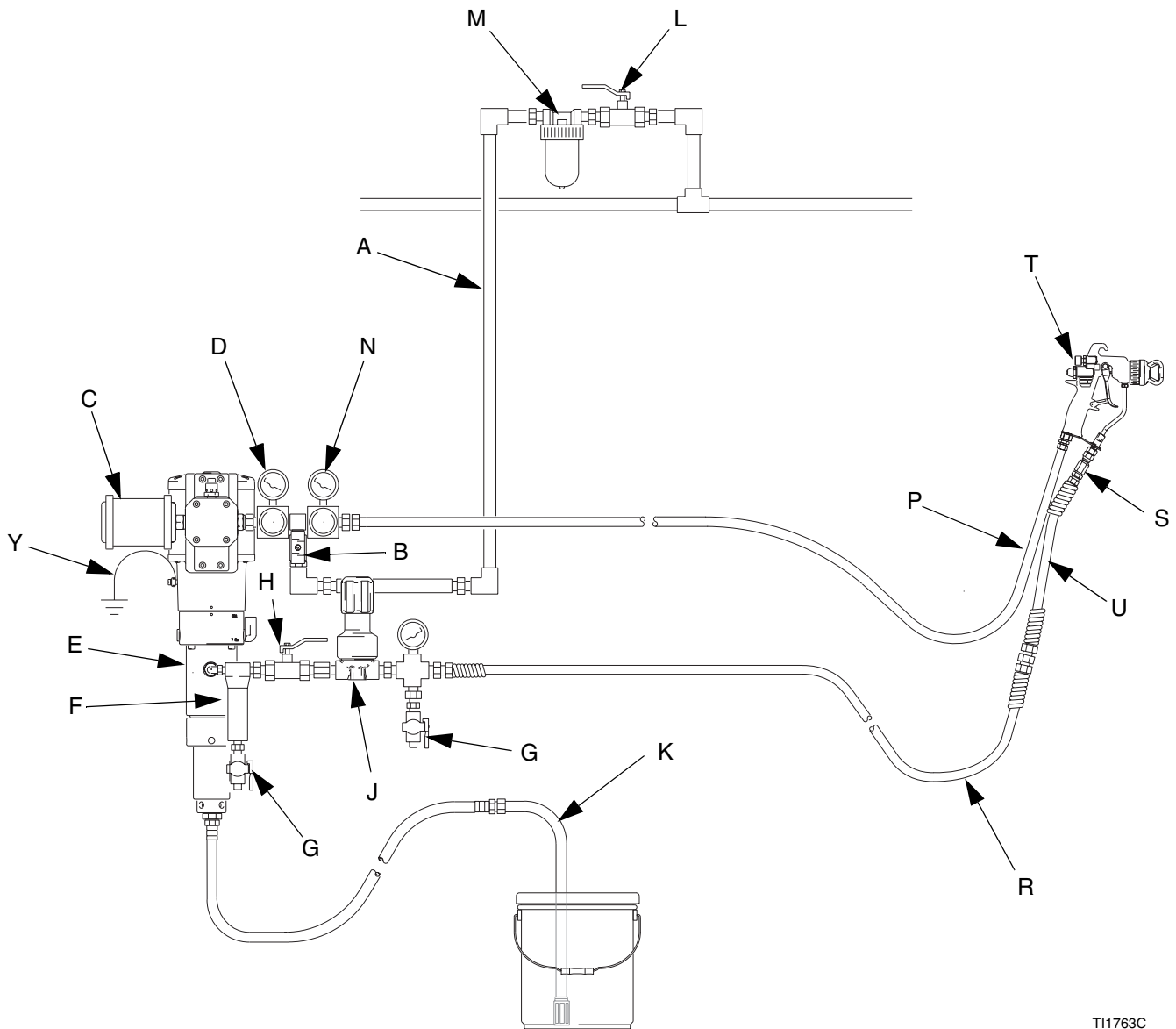

TI1763C

FIG. 2. Typical Installation (Wall Mount Shown)

Key:

- | | |
|-------------------------------|------------------------------|
| A Pump Air Supply Line | L Air Shutoff Valve |
| B Bleed-Type Master Air Valve | M Air Line Filter |
| C Muffer | N Gun Air Pressure Regulator |
| D Pump Air Pressure Regulator | P Gun Air Supply Line |
| E Pump | R Gun Fluid Supply Line |
| F Fluid Filter | S Gun Swivel |
| G Fluid Drain Valve | T Air-Assisted Spray Gun |
| H Fluid Shutoff Valve | U Fluid Whip Hose |
| J Fluid Pressure Regulator | Y Pump Ground Wire |
| K Fluid Suction Tube | |

Operation

Pressure Relief Procedure

⚠ WARNING



Read the warnings on page 4, and follow the Pressure Relief Procedure below whenever you:

- are instructed to relieve pressure
- stop spraying
- check or service any of the equipment
- install or clean the spray tip.

1. Lock the trigger.

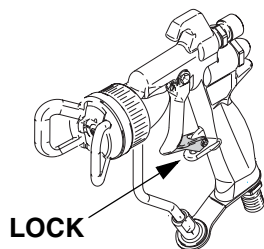

2. Turn off the air bleed valves to the fluid source and to the gun.



3. Unlock the trigger.

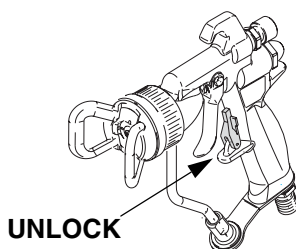

4. Trigger the gun into a grounded metal waste container to relieve the fluid pressure.

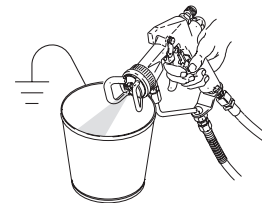

5. Lock the trigger.

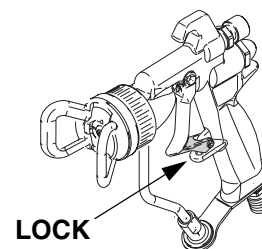

6. Open the drain valve on the fluid filter and all other fluid drain valves in the system, having a waste container ready to catch the drainage. Leave the drain valve(s) open until you are ready to spray again.

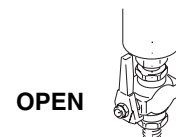

7. If the nozzle or hose is completely clogged or pressure is not fully relieved, slowly loosen the hose end coupling. Now clear the nozzle or hose.

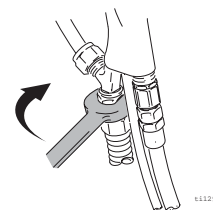

Flush the Pump Before First Use

The pump is tested with lightweight oil, which is left in to protect the pump parts. If the fluid you are using may be contaminated by the oil, flush it out with a compatible solvent before using the pump. See **Flush the Equipment** on page 11.

Starting and Adjusting the Pump

1. Connect the suction kit (K) to the pump's fluid inlet, and place the tube into the fluid supply.
2. Close the air regulator (D).



3. Open the pump's bleed-type master air valve (B).

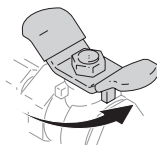

4. Hold a metal part of the gun (T) firmly to the side of a grounded metal pail and hold the trigger open.

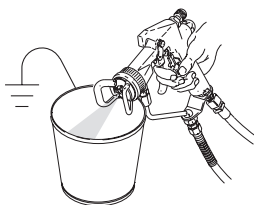

5. Slowly open the air regulator (D) until the pump starts.

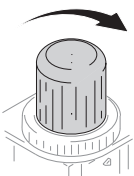

6. Cycle the pump slowly until all air is pushed out and the pump and hoses are fully primed.
7. Release the gun trigger and lock the trigger safety latch. The pump should stall against pressure.

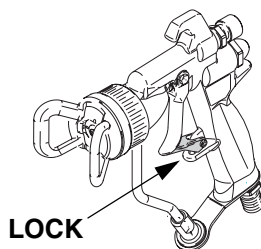

8. If the pump fails to prime properly, open the drain valve (G). Use the drain valve as a priming valve until fluid flows from the valve. Close the drain valve when all air is eliminated.

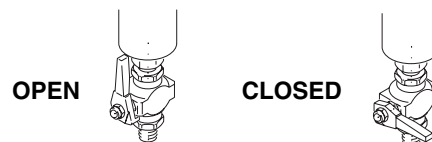

9. With the pump and lines primed, and with adequate air pressure and volume supplied, the pump will start and stop as you open and close the gun. In a circulating system, the pump will speed up or slow down on demand, until the air supply is shut off.
10. Use the air regulator to control the pump speed and the fluid pressure. Always use the lowest air pressure necessary to get the desired results. Higher pressures cause premature tip and pump wear.

CAUTION

Never allow the pump to run dry of the fluid being pumped. A dry pump will quickly accelerate to a high speed, possibly damaging itself. If your pump accelerates quickly, or is running too fast, stop it immediately and check the fluid supply. If the supply container is empty and air has been pumped into the lines, refill the container and prime the pump and the lines with fluid, or flush and leave it filled with a compatible solvent. Be sure to eliminate all air from the fluid system.

Shutdown and Care of the Pump

For a brief shutdown, relieve the pressure, page 9. Stop the pump at the bottom of its stroke to prevent fluid from drying on the exposed displacement rod and damaging the throat packings.

For a longer shutdown, or overnight, always flush the pump before the fluid dries on the displacement rod, page 11. Relieve the pressure, page 9.

Flush the Equipment

Flush before changing colors, at the end of the day, before storing, and before repairing the equipment.

⚠ WARNING



Before flushing, be sure the entire system and all grounding pails are properly grounded. See page 6.

Flush with a fluid that is compatible with the fluid you are pumping and with the wetted parts of your system. Check with your fluid manufacturer or supplier for recommended flushing fluids and flushing frequency. Always flush the pump before fluid dries on the displacement rod.

1. Relieve the pressure, page 9.

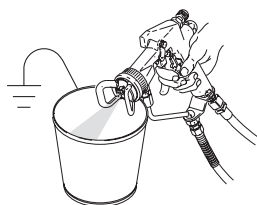

2. Remove the spray tip from the gun. See the gun manual.

3. Change the fluid source to solvent.



4. Hold a metal part of the gun firmly to the side of a grounded metal pail.
5. Start the pump. Always use the lowest possible fluid pressure when flushing.

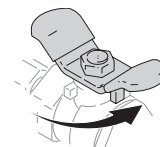

6. Trigger the gun. Flush until clean solvent flows from the gun.

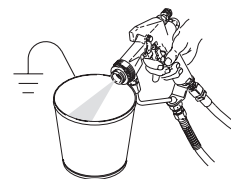

7. Relieve the pressure, page 9.

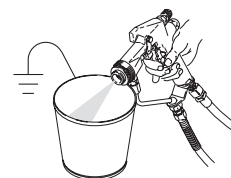

Maintenance

Preventive Maintenance Schedule

Establish a preventive maintenance schedule, based on the pump's service history.

Storage

Before storing the pump, always flush it, page 11. Relieve the pressure, page 9.

Tightening Threaded Connections

Before each use, check all hoses for wear or damage. Replace as necessary. Check that all threaded connections are tight and leak-free.

Cleaning

Clean the outside of the equipment daily, using a soft cloth and compatible solvent.

Clean the suction tube (K) and inlet strainer daily, using a compatible solvent.

Clean the air filter (M) in your main air line at least once a week.

Wet-Cup

The level display (70) is an indicator of the fluid level in the wet-cup (3). Keep the level display 1/2 full of Graco Throat Seal Liquid (TSL, supplied) or another compatible fluid.

Periodically drain the wet-cup by removing the plug (67), then refill with clean TSL.

Troubleshooting

1. Relieve the pressure (page 9) before checking or servicing the equipment.
2. Check all possible problems and causes before disassembling the pump.

Problem	Cause	Solution
Pump fails to operate.	Restricted line or inadequate air supply; closed or clogged valves.	Clear line or increase air supply. Check that valves are open.
	Obstructed fluid hose or gun; fluid hose ID is too small.	Open, clear*; use hose with larger ID.
	Fluid dried on the displacement rod.	Clean; always stop pump at the bottom of its stroke. Keep wet-cup filled with compatible fluid.
	Dirty, worn, or damaged air motor parts.	Clean or repair air motor. See page 16.
Pump operates, but output is low on both strokes.	Restricted line or inadequate air supply; closed or clogged valves.	Clear line or increase air supply. Check that valves are open.
	Obstructed fluid hose or gun; fluid hose ID is too small.	Open, clear*; use hose with larger ID.
	Fluid too heavy for pump priming.	Use ram.
	Worn packings in displacement pump.	Replace packings.
Pump operates, but output is low on downstroke.	Held open or worn intake valve.	Clear valve, service. See page 19.
	Fluid too heavy for pump priming.	Use ram.
Pump operates, but output is low on upstroke.	Held open or worn piston valve or packings.	Clear valve; replace packings. See page 20.
Erratic or accelerated pump speed.	Exhausted fluid supply.	Refill and prime.
	Fluid too heavy for pump priming.	Use ram.
	Held open or worn piston valve or packings.	Clear valve; replace packings. See page 20.
	Held open or worn intake valve.	Clear valve, service. See page 19.
Fluid being pumped is visible in the level display.	Worn throat packings.	Replace throat packings. See page 21. Clean level display (70).

* To determine if the fluid hose or gun is obstructed, relieve the pressure. Disconnect the fluid hose and place a container at the pump fluid outlet to catch any fluid. Turn on the air just enough to start the pump. If the pump starts when the air is turned on, the obstruction is in the hose or gun.

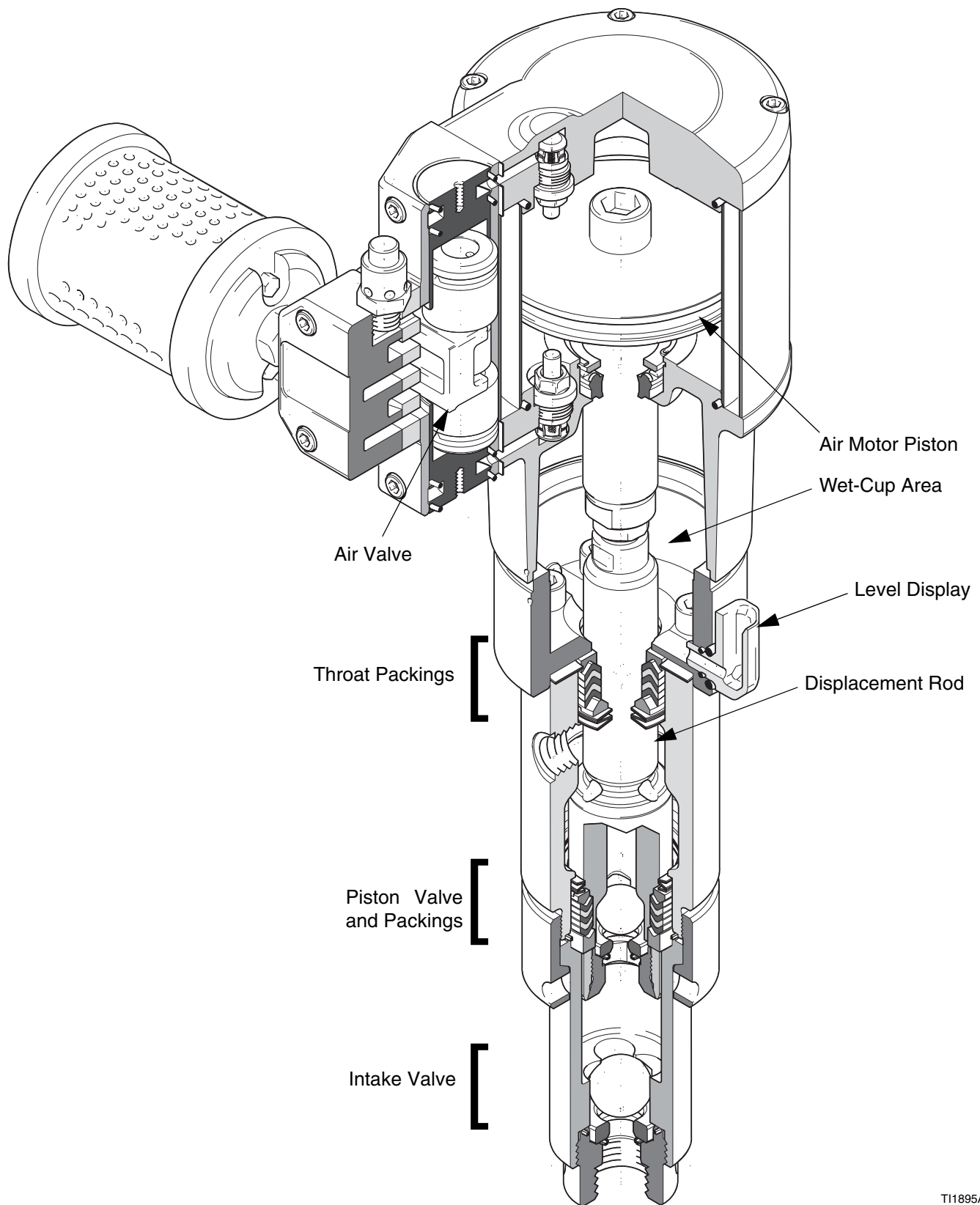

T11895A

FIG. 3. Cutaway View

Repair

Tools Required

- torque wrench
- supplied tool (107) or spanner wrench
- set of allen wrenches
- clip removal tool

Disconnect the Motor from the Displacement Pump



Repair of the fluid intake valve and fluid piston valve does not require removal of the displacement pump. See pages 19 and 20.

1. Flush the pump, if possible (page 11). Relieve the pressure (page 9).
2. Disconnect the air and fluid hoses and the ground wire.
3. Remove the pump from its mounting and take it to the work bench.
4. Remove the screws (103) holding the displacement pump (102) to the air motor (101).
5. Turn the air motor off the displacement pump.

Reconnect the Motor to the Displacement Pump

1. Turn the air motor (101) onto the displacement pump (102). Align the two indexing marks (X^1 , X^2); the pump fluid outlet (U) will face the same direction as the air valve (V). See FIG. 4.

2. Install the screws (103) to attach the displacement pump (102) to the air motor (101). Torque to 6.5-7.5 N•m (57-66 in-lb).
3. Reinstall the pump on its mounting.
4. Reconnect the ground wire and the air and fluid hoses. Return the pump to service.

 Torque to 6.5-7.5 N•m (57-66 in-lb)

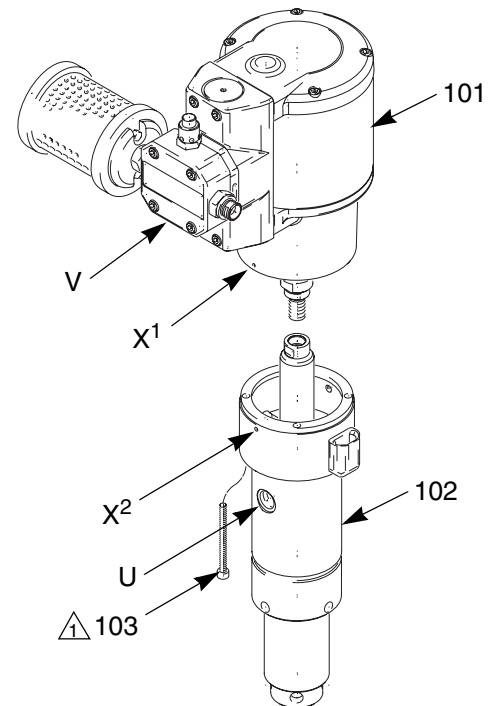

T11975A

FIG. 4. Pump Connection

Air Valve Repair

To repair the air valve, order Repair Kit 233836. Parts included in the kit are marked, for example (18†).

1. Remove the screws (19) and take the air valve housing (21) off the air motor. Remove the gaskets (18). See FIG. 5.

 Torque to 10-11 N•m (90-100 in-lb)

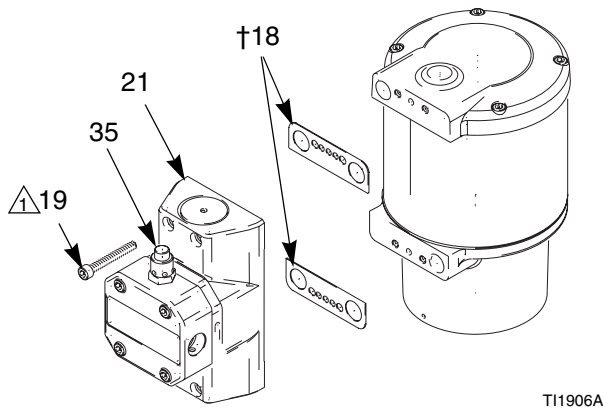



FIG. 5. Air Valve

2. Remove the air valve cover (31), seat (30), and cup (29). See FIG. 6.

 Torque to 10-11 N•m (90-100 in-lb)

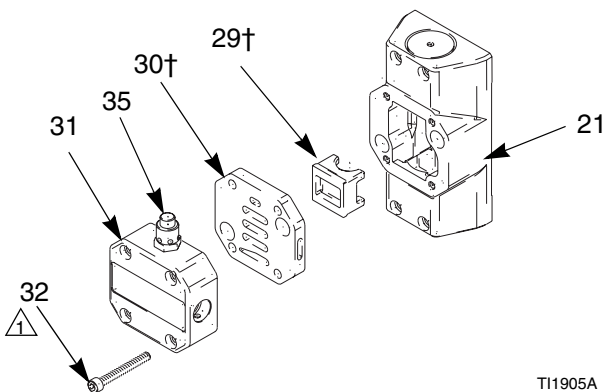

FIG. 6. Air Valve Cover, Seat, and Cup

3. Remove the setscrews (36). Disassemble the piston assembly. See FIG. 7.

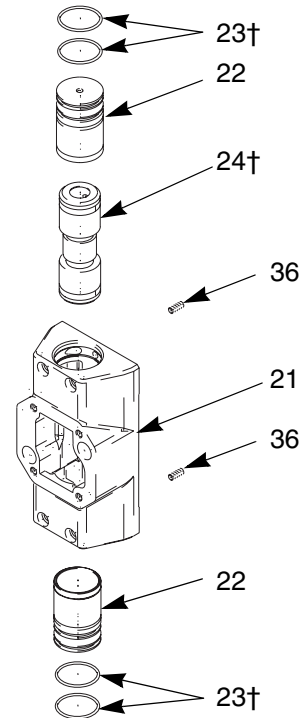

FIG. 7. Air Valve Piston Assembly

4. Install the o-rings (23†) on the bushings (22) and install one bushing in the housing (21). Install the piston (24†) and the other bushing. Install the setscrews (36) to secure.
5. Place the cup (29†) into the housing (21) so it rides on the air valve piston. See FIG. 6.
6. Install the seat (30†) and cover (31) as shown. Make sure the holes in the seat align with the holes in the housing (21), and note the orientation of the relief valve (35) in the cover. Torque the screws (32) to 10-11 N•m (90-100 in-lb).
7. Grease the inside surfaces of the housing (21) facing the gaskets (18†), then position the gaskets as shown in FIG. 5. Install the air valve with the relief valve (35) facing up. Torque the screws (19) to 10-11 N•m (90-100 in-lb).

Air Motor Piston and Cylinder Repair

Disassembly

NOTE: Air Motor Seal Repair Kits are available. See the chart on page 27 to order the correct kit for your motor. Parts included in the kit are marked, for example (7‡).

To repair the piston rod, order Repair Kit 233838. Parts included in the kit are marked, for example (11★).

1. Disconnect the displacement pump from the air motor (page 15).
2. Remove the air valve (page 16).
3. Remove the screws (10). Lift the top cover (6) off the air motor. Turn the cover over and remove the pilot valve (3). Remove the o-ring (7). See FIG. 8.

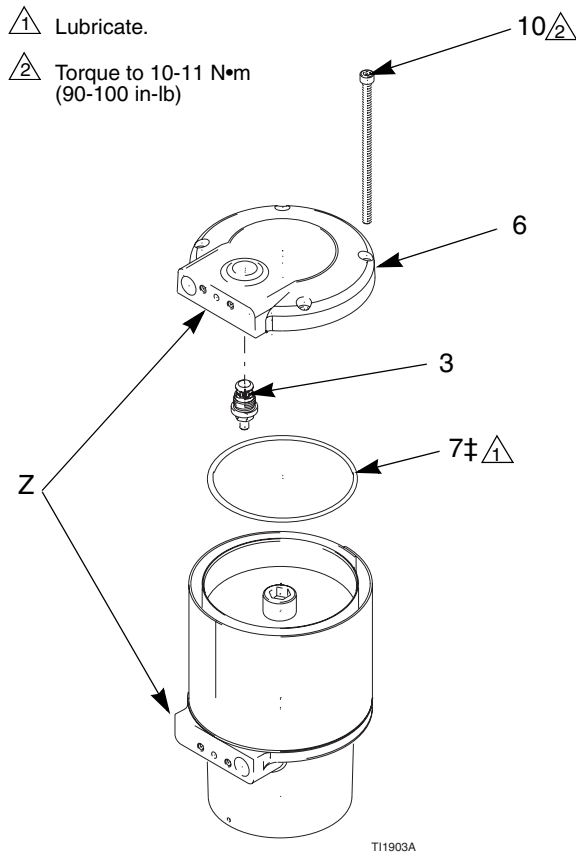

FIG. 8. Top Cover

4. Remove the side cover (4) and cylinder (5). Inspect the inside surface of the cylinder for scratches or other damage. See FIG. 9.

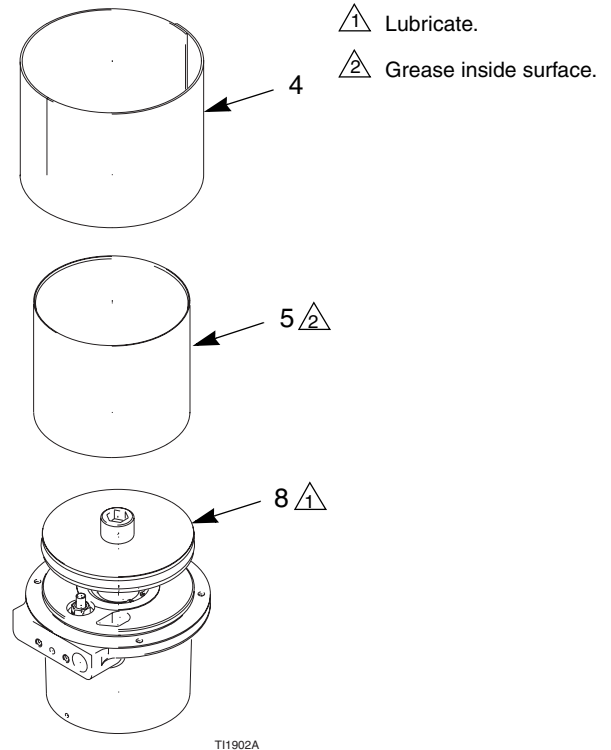





FIG. 9. Side Cover and Cylinder

5. Pull the piston (8) and rod (12) straight out of the air motor base (2). Do not tilt the piston to prevent damage to the rod. Remove the o-ring (9) and pilot valve (3). See FIG. 10.
6. Inspect the piston rod (12) for wear or damage. If the rod is damaged, disassemble the piston assembly. Keep the connecting rod (104) and the piston (8) for reuse. Discard the piston rod (12) and the cap screw (11). These parts must be replaced together.

-  Lubricate.
-  Torque to 150-163 N•m (110-120 ft-lb)
-  Torque to 61-68 N•m (45-50 ft-lb)

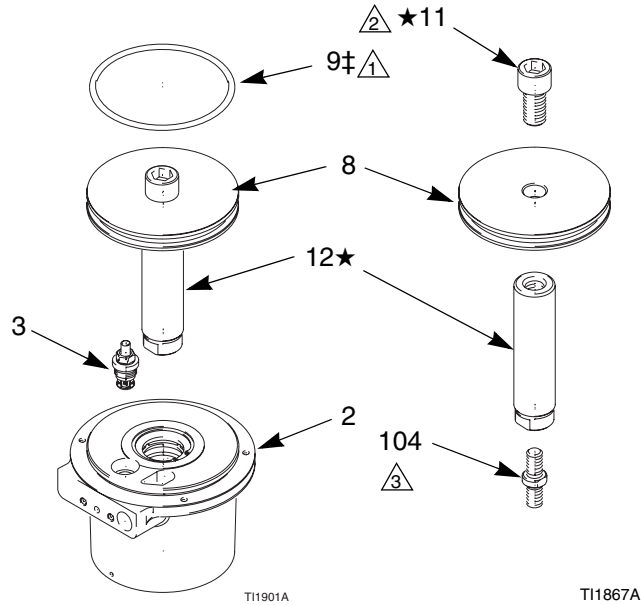



FIG. 10. Air Motor Piston

7. Remove the o-ring (7) from the air motor base. Use a clip removal tool to take out the c-clip (15), then remove the washer (14), ring (13‡ A), and seal (13‡ B). Note the orientation of these parts. See FIG. 11.

-  Lubricate.

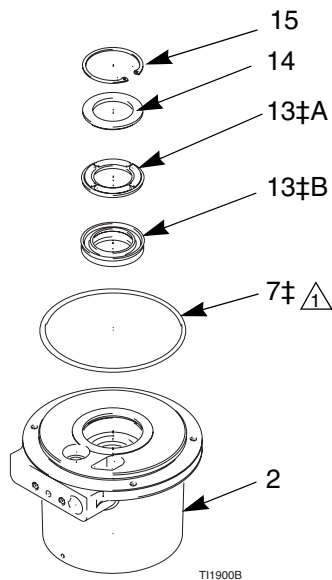



FIG. 11. Air Motor Base

Reassembly

1. Place the o-ring (7‡) on the air motor base (2). Lubricate the o-ring and the center bore in the base. Install the seal (13‡ B) with the groove facing up. Install the ring (13‡ A) in groove with notches facing up. Install the washer (14) with the flat side facing up, then the c-clip (15). See FIG. 11.
2. If the piston was disassembled, reassemble the cap screw (11★), piston (8), rod (12★), and connecting rod (104). See FIG. 10. Make sure the flat side of the piston faces up. Torque the cap screw to 150-163 N•m (110-120 ft-lb) using Loctite® from kit on threads. Torque the connecting rod to 61-68 N•m (45-50 ft-lb).
3. Install the pilot valve (3) in the base (2). Place the o-ring (9‡) on the piston (8). Grease the piston rod (12) and o-ring (9), and carefully lower the piston into the base.
4. Generously grease the lower half of the cylinder's (5) inside surface. Install the cylinder and the side cover (4). See FIG. 9.
5. Install the o-ring (7‡) and the pilot valve (3) on the inside surface of the top cover (6). Lubricate the o-ring. Install the top cover (6), making sure the air valve porting (Z) faces the same way as the porting on the base. Torque the screws (10) to 10-11 N•m (90-100 in-lb). See FIG. 8.
6. Reinstall the air valve (page 16).
7. Reconnect the displacement pump to the air motor (page 15).

Displacement Pump Repair

Intake Valve

 Intake Ball and Seat Repair Kits are available. See the chart on page 31 to order the correct kit for your pump. Parts included in the kit are marked, for example (79⇄).

1. Flush the pump, if possible (page 11). Relieve the pressure (page 9).
2. Using the supplied tool (107) or a spanner wrench, unscrew the intake housing (83) from the lower cylinder (77). Disassemble the intake valve. See FIG. 12.
3. Clean and inspect all parts.
4. Replace the seals (80⇄, 82⇄) and seat (81⇄). Lubricate the seal (80⇄) and threads of the housing (83). Place the ball (79⇄) on the seat. Screw the housing into the lower cylinder (77). Torque to 47-54 N•m (35-40 ft-lb).

 1 Lubricate.

 2 Torque to 47-54 N•m (35-40 ft-lb)

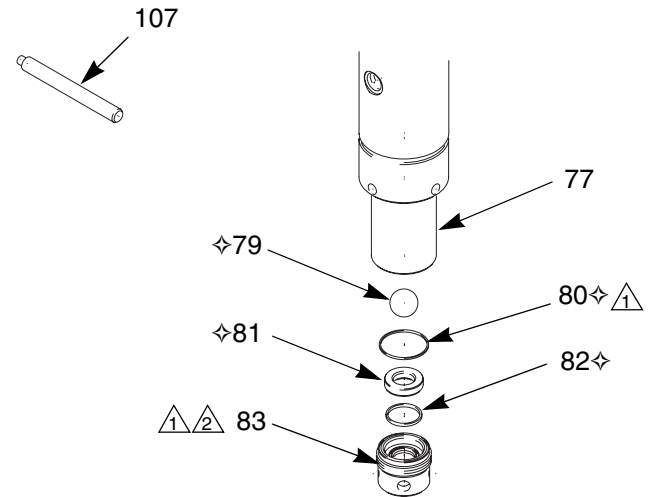

TI1968A

FIG. 12. Intake Valve

Piston Valve

-  Pump Seal Repair Kits are available. See the chart on page 31 to order the correct kit for your pump. Parts included in the kit are marked, for example (73*).
 - Piston Ball and Seat Repair Kits are available. See the chart on page 31 to order the correct kit for your pump. Parts included in the kit are marked, for example (52♦).
1. Flush the pump, if possible (page 11). Relieve the pressure (page 9).
 2. Using the supplied tool (107) or a spanner wrench, unscrew the union nut (78) from the upper cylinder (57) and slide it off the pump. Remove the lower cylinder (77) and the flat seal (76). Inspect the inner surface of the cylinder for damage. See FIG. 13.

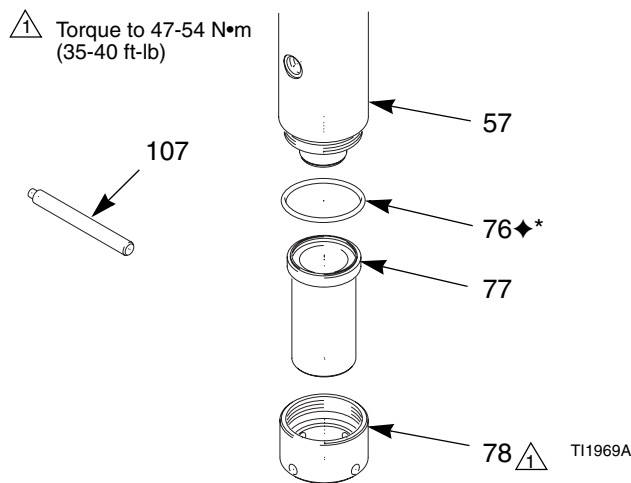

FIG. 13. Lower Cylinder

7. Install the seal (76♦) on the lower cylinder (77). Install the female gland (72), v-packings (73*, 74*), and male gland (75) into the cylinder. Alternate the v-packings, with the lips facing up. See FIG. 14.
8. Lubricate the inside and outside of the packings.
9. Assemble the spring discs (71); the bottom two face up, middle two face down, top two face up. Place the spring on top of the packing stack.
10. Position the lower cylinder (77) over the end of the displacement rod (51), sliding the packing stack onto the rod and into the upper cylinder (57).
11. Slide the union nut (78) onto the lower cylinder (77) and thread it onto the upper cylinder (57). Tighten with a spanner wrench. Torque to 47-54 N•m (35-40 ft-lb). See FIG. 13.

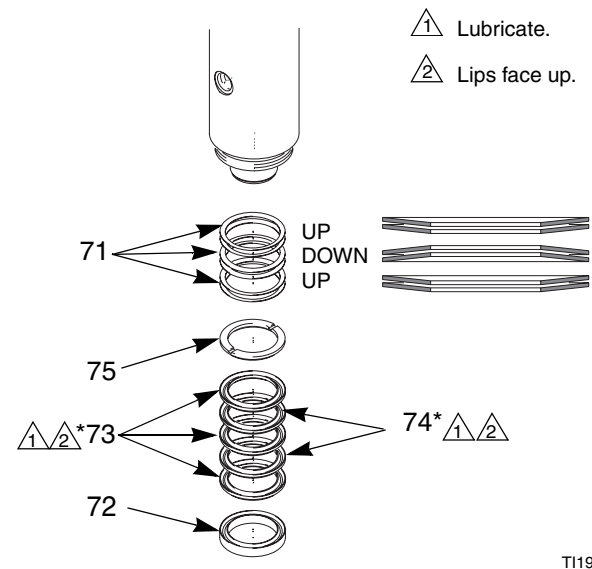

FIG. 14. Piston Packings

3. Remove the piston packings. See FIG. 14.
4. Unscrew the piston body (56) from the rod (51). Disassemble the piston. See FIG. 15.
5. Clean and inspect all parts.
6. Install the o-ring (55♦) and seat (54♦) in the piston body (56). Install the large o-ring (53♦). Lubricate the o-ring (53♦) and threads of the piston. Place the ball (52♦) on the seat. Screw the piston into the rod (51). Torque to 102-108 N•m (75-80 ft-lb).

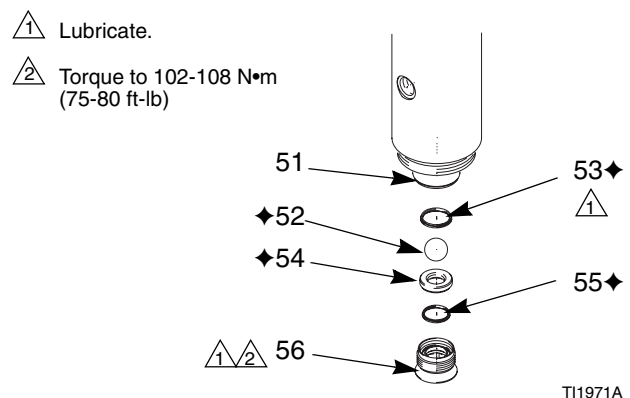

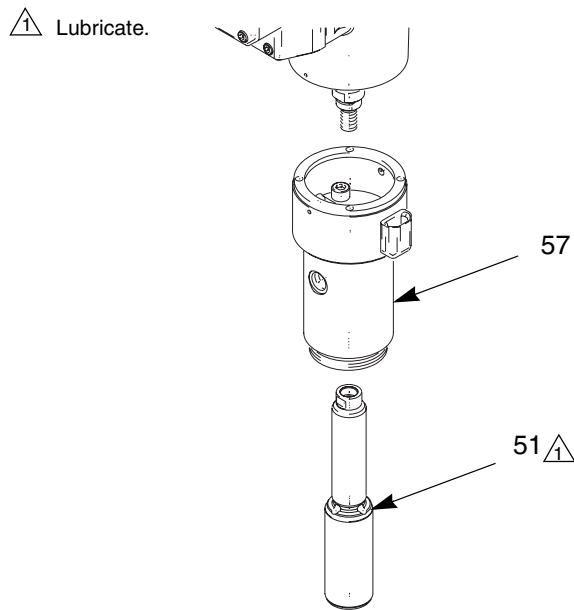

FIG. 15. Piston Valve

Cylinder, Rod, and Throat Packing Repair

-  Pump Seal Repair Kits are available. See the chart on page 31 to order the correct kit for your pump. Parts included in the kit are marked, for example (60*).
- To repair the wet-cup level display, order Repair Kit 233829. Parts included in the kit are marked, for example (68**).

1. Relieve the pressure (page 9).
2. Disconnect the displacement pump from the air motor, page 15.
3. Remove the intake valve, page 19.
4. Remove the lower cylinder (77), flat seal (76), and piston packings, page 20.
5. Pull the displacement rod (51) down, out of the upper cylinder (57). Inspect the surface of the rod and replace if damaged. To repair the piston, see page 20.



TI1973A

FIG. 16

6. Remove the screws (65) and lift the wet-cup (64) off the pump. Remove the gasket (63). See FIG. 17.

-  If leaking is observed at the wet-cup, replace the seals (68**, 69**, 66) and the level display (70**).

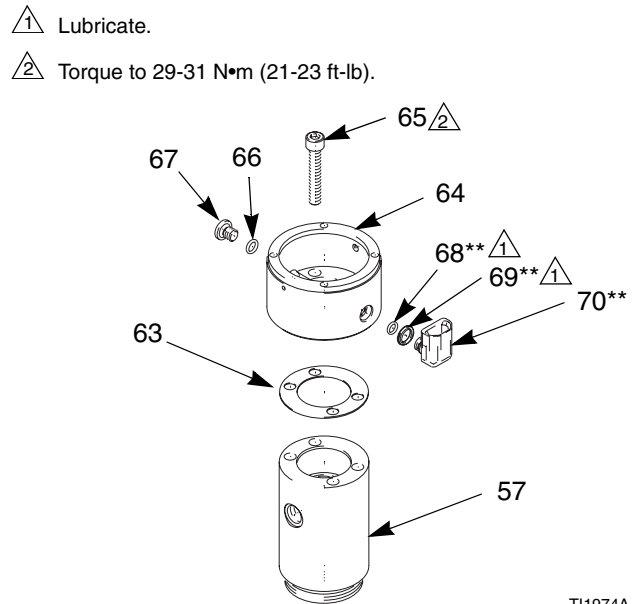

TI1974A

FIG. 17. Wet-Cup

7. Remove the throat packings and the springs from the upper cylinder (57). See FIG. 18.

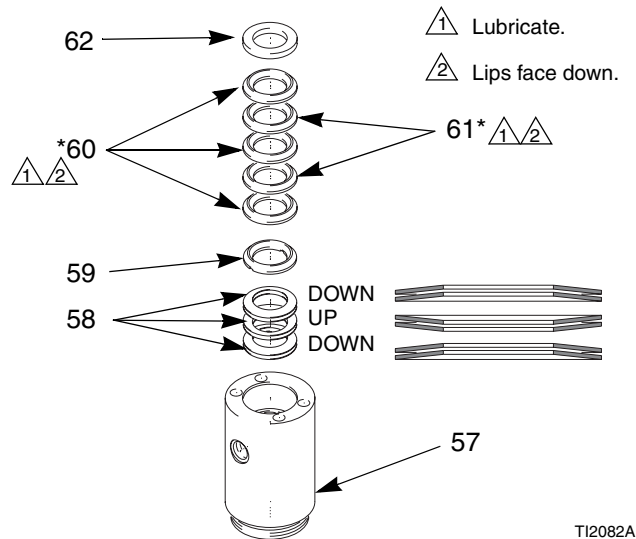

TI2082A

FIG. 18. Throat Packings

8. Assemble the spring discs (58); the bottom two face down, middle two face up, top two face down. Place the spring into the upper cylinder (57).
9. Install the male gland (59), v-packings (60*, 61*), and female gland (62) into the cylinder. Alternate the v-packings, with the lips facing down. Lubricate the packings.

10. Install the gasket (63*); make sure the holes align with the holes in the upper cylinder (57).
11. Position the wet-cup (64) on the upper cylinder (57) with the level display (70) oriented 90° counterclockwise from the fluid outlet (U), as shown in FIG. 17. Install the screws (65) and torque to 29-31 N•m (21-23 ft-lb).
12. Lubricate the displacement rod (51) and push it up into the cylinder (57) until it protrudes from the wet-cup.
13. Install the piston packings, flat seal (76), and lower cylinder (77), page 20.
14. Install the intake valve, page 19.
15. Reconnect the displacement pump to the air motor (page 15).

Parts

Complete Pump

Pump Part No.	Series	Pump Ratio	Pump Model	Displacement Volume per Stroke	Thread Type
233752	A	15:1	015.050 BSPP	50 cc (1.7 oz)	BSPP
233753	A	20:1	020.035 BSPP	35 cc (1.2 oz)	BSPP
233754	A	30:1	030.020 BSPP	20 cc (0.7 oz)	BSPP
233755	A	30:1	030.050 BSPP	50 cc (1.7 oz)	BSPP
233756	A	40:1	040.035 BSPP	35 cc (1.2 oz)	BSPP
233818	A	15:1	015.050 NPT	50 cc (1.7 oz)	NPT
233819	A	20:1	020.035 NPT	35 cc (1.2 oz)	NPT
233820	A	30:1	030.020 NPT	20 cc (0.7 oz)	NPT
233821	A	30:1	030.050 NPT	50 cc (1.7 oz)	NPT
233822	A	40:1	040.035 NPT	35 cc (1.2 oz)	NPT

Part Nos. 233752, 233753, 233754, 233755, and 233756 include items 101-107
Part Nos. 233818, 233819, 233820, 233821, and 233822 include items 101-110

Ref. No.	Part No.	Description	Qty
101	245354	MOTOR, air, D110; for 233752, 233753, 233754, 233818, 233819, and 233820; see page 26	1
	245355	MOTOR, air, D160; for 233755, 233756, 233821, and 233822; see page 26	1
102	245351	DISPLACEMENT PUMP, 020; for 233754 and 233820; see page 28	1
	245352	DISPLACEMENT PUMP, 050; for 233752, 233755, 233818, and 233821; see page 28	1
	245353	DISPLACEMENT PUMP, 035; for 233753, 233756, 233819, and 233822; see page 28	1
103	117083	SCREW, socket-hd; M6 x 70	4
104	15A087	ROD, connecting	1
105	117237	MUFFLER	1
106	206994	THROAT SEAL LIQUID; 0.24 l (8 oz); not shown	1
107	15A724	TOOL, pump repair	1
108	15A641	NIPPLE, fluid outlet; 3/8 npt x 3/8 bspt; for 233818, 233819, 233820, 233821, and 233822 only	1
109	245681	ADAPTER, fluid inlet; 3/4 npt(m) x M26 x 1.5; for 233818, 233819, 233820, 233821, and 233822 only; includes item 109a	1
109a	15F150	. O-RING	1
110	245718	ADAPTER, air inlet; 1/4 npt(m); for 233818, 233819, 233820, 233821, and 233822 only; includes item 110a	1
110a	117114	. O-RING	1

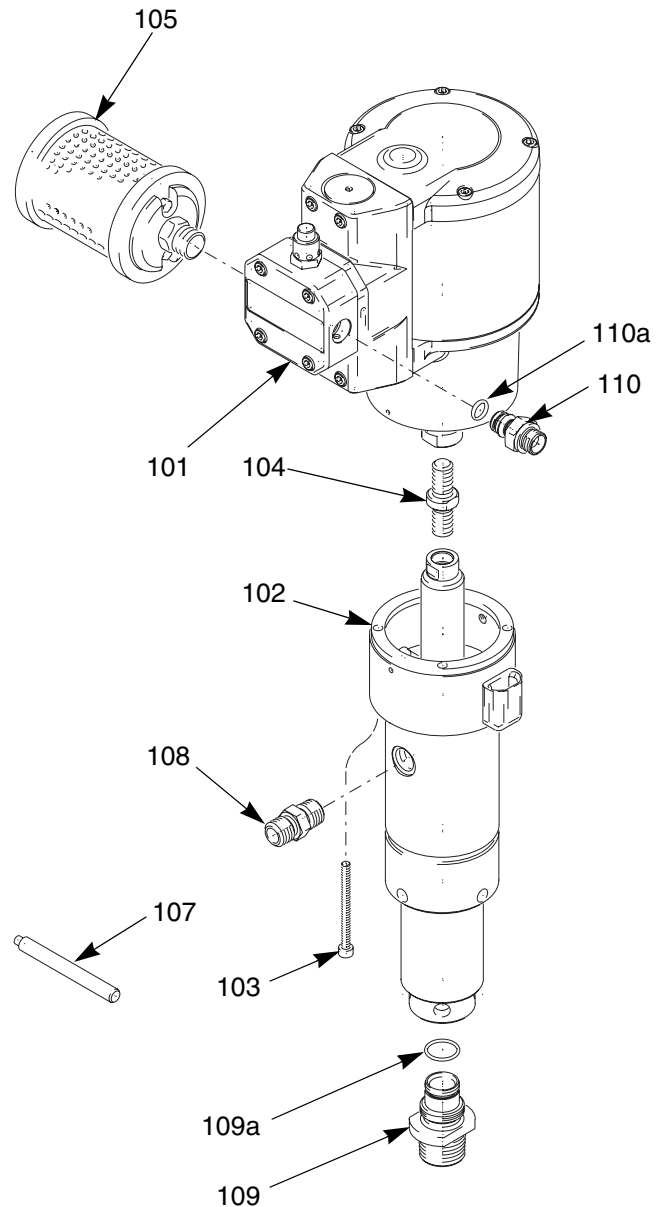

T11864A



A series of horizontal lines for writing, consisting of 25 evenly spaced lines that span the width of the page.

Part No. 245354 D110 Air Motor, Series B**Part No. 245355 D160 Air Motor, Series B**

Ref. No.	Part No.	Description	Qty	Ref. No.	Part No.	Description	Qty
				20	245357	VALVE, Air Includes 21-33 and 36	1
2	245828	COVER, bottom; for 245354	1	21	.15A110	HOUSING, air valve	1
	245829	COVER, bottom; for 245355	1	22	.15A056	BUSHING, air valve	2
3	245350	VALVE, pilot	2	23†	.	O-RING	4
4	15A104	COVER, side; for 245354	1	24†	.245356	CARRIAGE, driver	1
	15A105	COVER, side; for 245355	1	29†	.	CUP, air valve	1
5	15A135	CYLINDER; for 245354	1	30†	.	SEAT, air valve	1
	15A136	CYLINDER; for 245355	1	31	.15A053	COVER, air valve	1
6	15A139	COVER, top; for 245354	1	32	.117078	SCREW, cap, socket hd; M6 x 45	4
	15A140	COVER, top; for 245355	1	33	.117052	SCREW, set; M6 x 12	1
7‡		O-RING, cylinder	2	34▲	196155	LABEL, warning	1
8	15A108	PISTON; for 245354	1	35	197660	VALVE, relief; 0.8 MPa, 8 bar (115 psi)	1
	15A109	PISTON; for 245355	1	36	117377	SCREW, set, cup pt; M5 x 0.8	2
9‡		O-RING, piston	1				
10	117084	SCREW, cap, socket hd; M6 x 125	4				
11★		SCREW, cap, socket hd; with patch; M6 x 16	1			† These parts are included in Air Valve Repair Kit 233836. See the chart below.	
12★		ROD, piston	1				
13‡A		RING	1			‡ These parts are included in the Air Motor Seal Repair Kits. See the chart below to order the correct kit for your air motor.	
13‡B		SEAL	1				
14	15A107	WASHER	1				
15	117069	CLIP, c-ring	1			★ These parts are included in Piston Rod Repair Kit 233838. See the chart below.	
16	116343	CLAMP, grounding	1				
17	111307	WASHER (used with #16, 116343)	1				
18† ‡		GASKET, air valve	2			▲ Replacement Warning labels, signs, tags, and cards are available at no cost.	
19	117276	SCREW, cap, socket hd; M6 x 50	4				

Air Motor Repair Kits

Air Motor Part No.	† Air Valve Repair Kit (includes items 18, 23, 24, 29, 30)	‡ Air Motor Seal Repair Kit (includes items 7, 9, 13A, 13B, 18)	★ Piston Rod Repair Kit (includes items 11, 12)
245354	233836	233837	233838
245355	233836	233842	233838

020, 035, and 050 Displacement Pumps

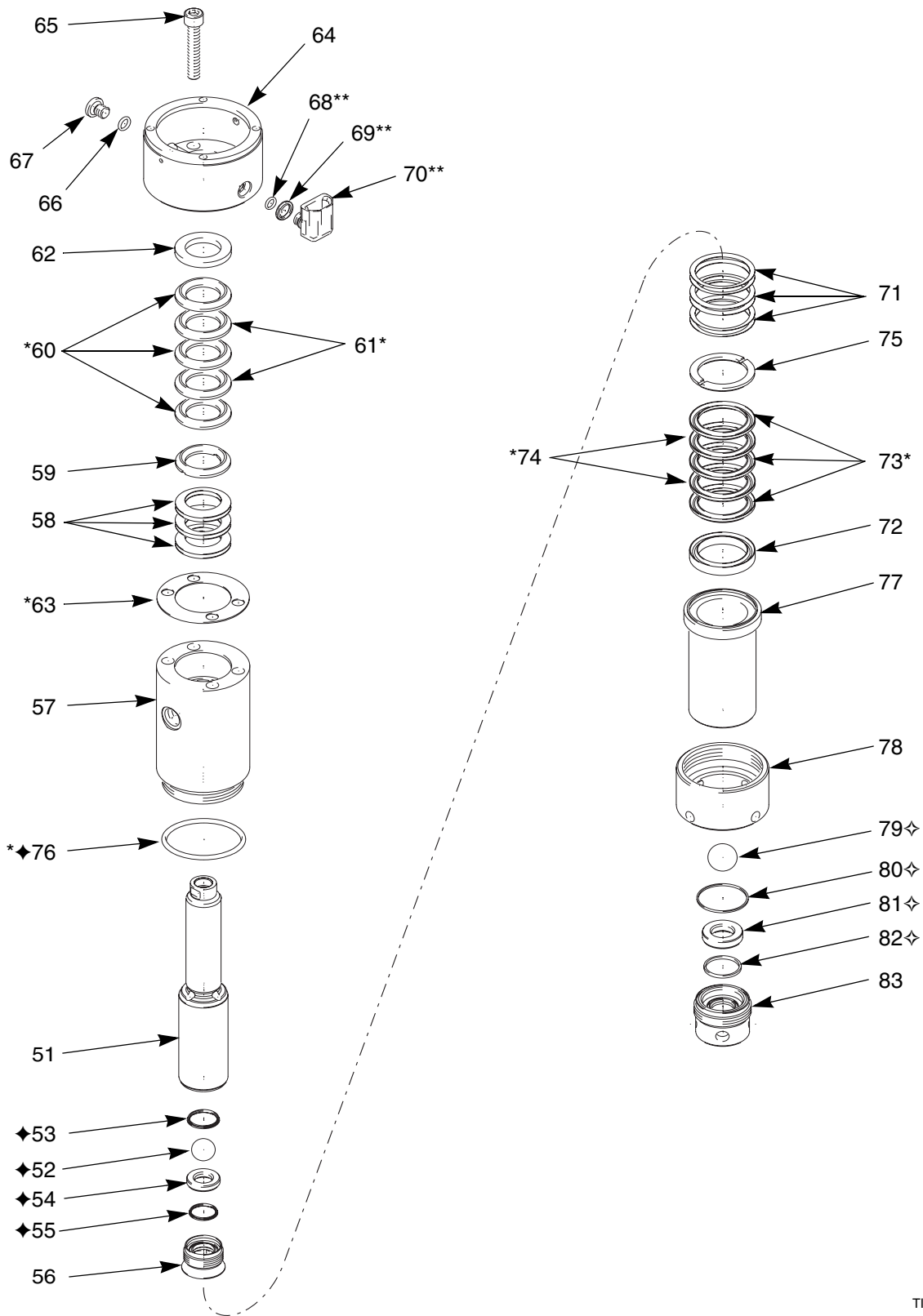

T11866A

Part No. 245351 020 Displacement Pump, Series A**Part No. 245352 050 Displacement Pump, Series A****Part No. 245353 035 Displacement Pump, Series A**

Ref. No.	Part No.	Description	Qty	Ref. No.	Part No.	Description	Qty
51	15A119	ROD, displacement; for 245351	1	68**		O-RING	1
	15A118	ROD, displacement; for 245352	1	69**		O-RING	1
	15A120	ROD, displacement; for 245353	1	70**		DISPLAY, level	1
52◆		BALL, piston	1	71	117072	SPRING, disc, piston; for 245351	6
53◆		SEAL, flat, piston; UHMWPE	1		117075	SPRING, disc, piston; for 245352	6
54◆		SEAT, valve, piston	1		117074	SPRING, disc, piston; for 245353	6
55◆		SEAL, valve, piston	1	72	15A070	GLAND, piston, female; for 245351	1
56	15A093	BODY, piston; for 245351	1		15A074	GLAND, piston, female; for 245352	1
	15A095	BODY, piston; for 245352	1		15A072	GLAND, piston, female; for 245353	1
	15A094	BODY, piston; for 245353	1				
57	15A130	CYLINDER, upper; for 245351	1	73*	15A064	V-PACKING, piston; UHMWPE; for 245351	3
	15A134	CYLINDER, upper; for 245352	1		15A068	V-PACKING, piston; UHMWPE; for 245352	3
	15A132	CYLINDER, upper; for 245353	1		15A066	V-PACKING, piston; UHMWPE; for 245353	3
58	117071	SPRING, disc, throat; for 245351	6	74*	15A058	V-PACKING, piston; PTFE; for 245351	2
	117076	SPRING, disc, throat; for 245352	6		15A062	V-PACKING, piston; PTFE; for 245352	2
	117073	SPRING, disc, throat; for 245353	6		15A060	V-PACKING, piston; PTFE; for 245353	2
59	15A112	GLAND, throat, male; for 245351	1	75	15A113	GLAND, piston, male; for 245351	1
	15A116	GLAND, throat, male; for 245352	1		15A117	GLAND, piston; male for 245352	1
	15A114	GLAND, throat, male; for 245353	1		15A115	GLAND, piston; male for 245353	1
60*	15A063	V-PACKING, throat; UHMWPE; for 245351	3	76*◆		SEAL, flat; UHMWPE	1
	15A067	V-PACKING, throat; UHMWPE; for 245352	3	77	15A129	CYLINDER, lower; for 245351	1
	15A065	V-PACKING, throat; UHMWPE; for 245353	3		15A133	CYLINDER, lower; for 245352	1
61*	15A057	V-PACKING, throat; PTFE; for 245351	2		15A131	CYLINDER, lower; for 245353	1
	15A061	V-PACKING, throat; PTFE; for 245352	2				
	15A059	V-PACKING, throat; PTFE; for 245353	2				
62	15A069	GLAND, throat, female; for 245351	1				
	15A073	GLAND, throat, female; for 245352	1				
	15A071	GLAND, throat, female; for 245353	1				
63*		GASKET, cylinder	1				
64	15A102	WET-CUP; for 245351	1				
	15A101	WET-CUP; for 245352	1				
	15A103	WET-CUP; for 245353	1				
65	117080	SCREW, cap, socket-hd; M10 x 60; for 245351	4				
	117081	SCREW, cap, socket-hd; M10 x 60; for 245352 and 245353	4				
66	117036	SEAL, flat, plug	1				
67	117077	PLUG, wet-cup	1				

Ref. No.	Part No.	Description	Qty	
78	15A121	NUT, union; for 245351	1	* These parts are included in the Seal Repair Kits. See the chart on page 31 to order the correct kit for your pump.
	15A123	NUT, union; for 245352	1	
	15A122	NUT, union; for 245353	1	
79	◇	BALL, intake	1	◆ These parts are included in the Piston Ball and Seat Repair Kits. See the chart on page 31 to order the correct kit for your pump.
80	◇	SEAL, flat; UHMWPE	1	
81	◇	SEAT, valve, intake	1	
82	◇	SEAL, intake	1	◇ These parts are included in the Intake Ball and Seat Repair Kits. See the chart on page 31 to order the correct kit for your pump.
83	15A096	HOUSING, intake; for 245351	1	
	15A098	HOUSING, intake; for 245352	1	
	15A097	HOUSING, intake; for 245353	1	** These parts are included in Wet-Cup Repair Kit 233829. See the chart on page 31.

Displacement Pump Repair Kits

Displacement Pump Part No.	* Seal Repair Kit (includes items 60, 61, 63, 73, 74, 76)	◆ Piston Ball and Seat Repair Kit (includes items 52, 53, 54, 55, 76)	◇ Intake Ball and Seat Repair Kit (includes items 79, 80, 81, 82)	** Wet Cup Repair Kit (includes items 68, 69, 70)
245351	233826	233827	233828	233829
245353	233830	233831	233832	233829
245352	233833	233834	233835	233829
245639	n/a	233827	233828	233829
245640	n/a	233831	233832	233829
245641	n/a	233834	233835	233829

ECOMIX Displacement Pumps

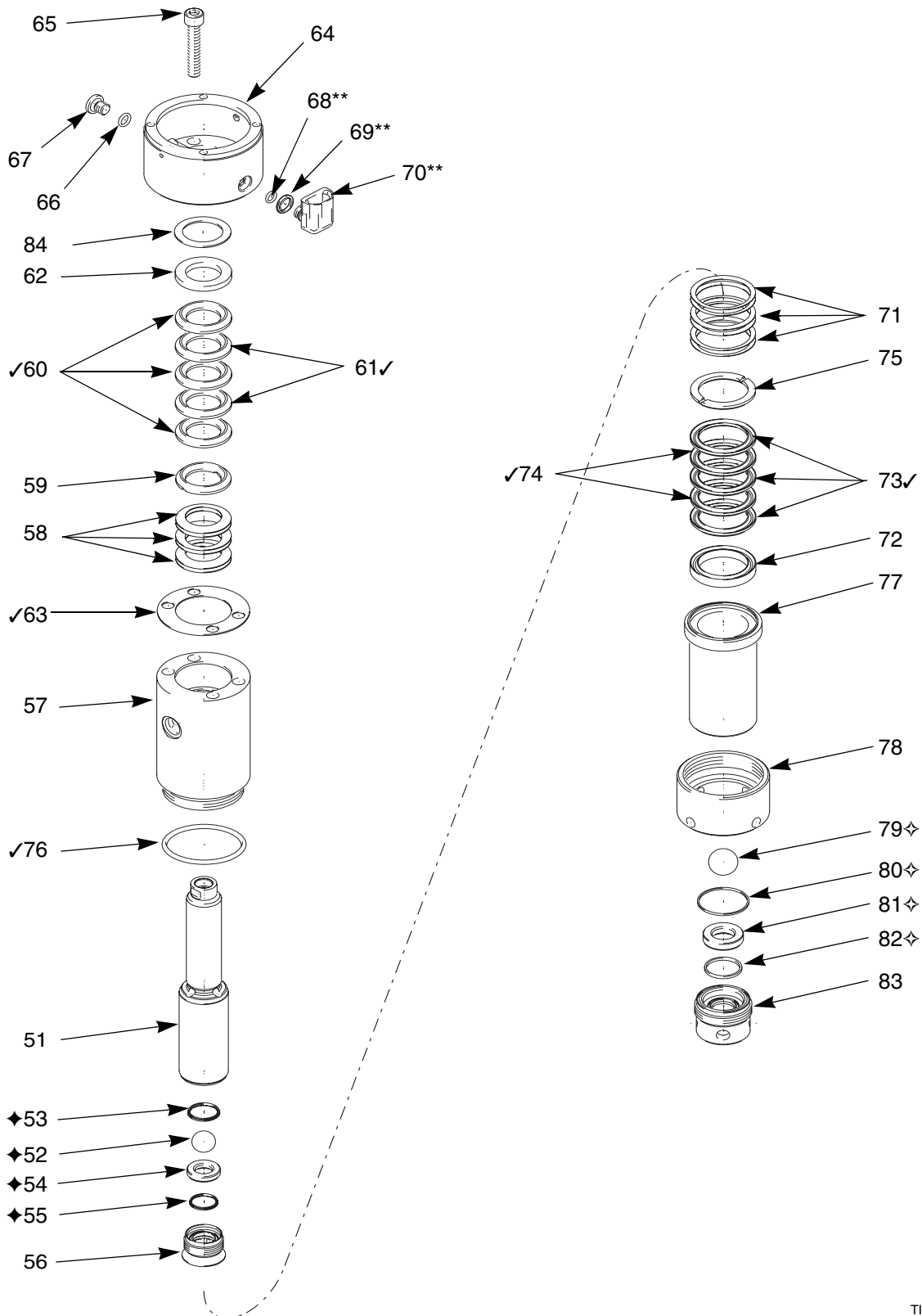

T11976A

Part No. 245639 020 ECOMIX Displacement Pump, Series A**Part No. 245640 035 ECOMIX Displacement Pump, Series A****Part No. 245641 050 ECOMIX Displacement Pump, Series A**

Ref. No.	Part No.	Description	Qty	Ref. No.	Part No.	Description	Qty
51	15A118	ROD, displacement; for 245641	1	66	117036	SEAL, flat, plug	1
	15A119	ROD, displacement; for 245639	1	67	117077	PLUG, wet-cup	1
	15A120	ROD, displacement; for 245640	1	68**		O-RING	1
52♦		BALL, piston	1	69**		O-RING	1
53♦		SEAL, flat, piston; UHMWPE	1	70**		DISPLAY, level	1
54♦		SEAT, valve, piston	1	71	117075	SPRING, disc, piston; for 245641	6
55♦		SEAL, valve, piston	1		117072	SPRING, disc, piston; for 245639	6
56	15A095	BODY, piston; for 245641	1		117074	SPRING, disc, piston; for 245640	6
	15A093	BODY, piston; for 245639	1	72	15A074	GLAND, piston, female; for 245641	1
	15A094	BODY, piston; for 245640	1		15A070	GLAND, piston, female; for 245639	1
57	15A134	CYLINDER, upper; for 245641	1		15A072	GLAND, piston, female; for 245640	1
	15A130	CYLINDER, upper; for 245639	1	73✓	15A068	V-PACKING, piston; UHMWPE; for 245641	3
	15A132	CYLINDER, upper; for 245640	1		15A064	V-PACKING, piston; UHMWPE; for 245639	3
58	117076	SPRING, disc, throat; for 245641	6		15A066	V-PACKING, piston; UHMWPE; for 245640	3
	117071	SPRING, disc, throat; for 245639	6				
	117073	SPRING, disc, throat; for 245640	6				
59	15A116	GLAND, throat, male; for 245641	1	74✓	15A062	V-PACKING, piston; PTFE; for 245641	2
	15A112	GLAND, throat, male; for 245639	1		15A058	V-PACKING, piston; PTFE; for 245639	2
	15A114	GLAND, throat, male; for 245640	1		15A060	V-PACKING, piston; PTFE; for 245640	2
60✓	15A061	V-PACKING, throat; PTFE; for 245641	3				
	15A057	V-PACKING, throat; PTFE; for 245639	3	75	15A117	GLAND, piston, male; for 245641	1
	15A059	V-PACKING, throat; PTFE; for 245640	3		15A113	GLAND, piston, male; for 245639	1
					15A115	GLAND, piston, male; for 245640	1
61✓	15A523	V-PACKING, throat; leather; for 245641	2	76✓	117042	SEAL, flat; UHMWPE; for 245641	1
	15A521	V-PACKING, throat; leather; for 245639	2		117040	SEAL, flat; UHMWPE; for 245639	1
	15A522	V-PACKING, throat; leather; for 245640	2		117041	SEAL, flat; UHMWPE; for 245640	1
62	15A073	GLAND, throat, female; for 245641	1	77	15A133	CYLINDER, lower; for 245641	1
	15A069	GLAND, throat, female; for 245639	1		15A129	CYLINDER, lower; for 245639	1
	15A071	GLAND, throat, female; for 245640	1		15A131	CYLINDER, lower; for 245640	1
63✓	15A083	GASKET, cylinder; for 245641	1	Continued on page 34.			
	15A081	GASKET, cylinder; for 245639	1				
	15A082	GASKET, cylinder; for 245640	1				
64	15A101	WET-CUP for 245641	1				
	15A102	WET-CUP; for 245639	1				
	15A103	WET-CUP; for 245640	1				
65	117081	SCREW, cap, socket-hd; M10 x 60; for 245641 and 245640	4				
	117080	SCREW, cap, socket-hd; M10 x 60; for 245639	4				

Ref. No.	Part No.	Description	Qty	
78	15A123	NUT, union; for 245641	1	✓ Recommended spare parts. Keep on hand to reduce downtime.
	15A121	NUT, union; for 245639	1	◆ These parts are included in the Piston Ball and Seat Repair Kits. See the chart on page 31 to order the correct kit for your pump.
	15A122	NUT, union; for 245640	1	
79	◆	BALL, intake	1	◆ These parts are included in the Intake Ball and Seat Repair Kits. See the chart on page 31 to order the correct kit for your pump.
80	◆	SEAL, flat; UHMWPE	1	
81	◆	SEAT, valve, intake	1	
82	◆	SEAL, intake	1	
83	15A098	HOUSING, intake; for 245641	1	** These parts are included in Wet-Cup Repair Kit 233829. See the chart on page 31.
	15A096	HOUSING, intake; for 245639	1	
	15A097	HOUSING, intake; for 245640	1	
84	15A701	SPACER	1	

Technical Data

Category	Data
Maximum fluid working pressure	Part No. 233752, 233818: 10.5 MPa, 105 bar (1500 psi) Part No. 233753, 233819: 14.0 MPa, 140 bar (2000 psi) Part No. 233754, 233755, 233820, 233821: 21.0 MPa, 210 bar (3000 psi) Part No. 233756, 233822: 28.0 MPa, 280 bar (4000 psi)
Maximum air input pressure	0.7 MPa, 7 bar (100 psi)
Minimum air input pressure	0.05 MPa, 0.5bar (7 psi)
Ratio	Part No. 233752, 233818: 15:1 Part No. 233753, 233819: 20:1 Part No. 233754, 233755, 233820, 233821: 30:1 Part No. 233756, 233822: 40:1
Volume per stroke	Part No. 233754, 233820: 20 cc (0.7 oz) Part No. 233753, 233756, 233819, 233822: 35 cc (1.2 oz) Part No. 233752, 233755, 233818, 233821: 50 cc (1.7 oz)
Fluid flow at 60 cycles per minute	Part No. 233754, 233820: 2.4 lpm (0.6 gpm) Part No. 233753, 233756, 233819, 233822: 4.2 lpm (1.1 gpm) Part No. 233752, 233755, 233818, 233821: 6.0 lpm (1.6 gpm)
Operating temperature range	10-71°C (50-160°F)
Air motor piston diameter	Part No. 245354: 110 mm (4.3 in.) Part No. 245355: 160 mm (6.3 in.)
Stroke length	70 mm (2.75 in.)
Displacement pump effective area	Part No. 233754, 233820: 2.85 cm ² (0.44 in. ²) Part No. 233753, 233756, 233819, 233822: 5.00 cm ² (0.77 in. ²) Part No. 233752, 233755, 233818, 233821: 7.14 cm ² (1.11 in. ²)
Wetted parts	301, 303, and 440C stainless steel, carbide, nylon, fluoroelastomer, ultra-high molecular weight polyethylene, PTFE ECOMIX displacement pumps: 301, 303, and 440C stainless steel, carbide, nylon, fluoroelastomer, ultra-high molecular weight polyethylene, PTFE, leather

Loctite® is a registered trademark of the Loctite Corporation.

Sound Pressure Levels in dB(A), measured at 1 m from equipment

Air Motor	Input Air Pressure			
	0.2 MPa, 2 bar (29 psi)	0.4 MPa, 4 bar (58 psi)	0.6 MPa, 6 bar (87 psi)	0.7 MPa, 7 bar (100 psi)
245354 (D110)	76	81	84	85
245355 (D160)	78	82	85	89

Performance Charts

Part Nos. 233752 and 233818, 15:1 Ratio, 50 cc (1.7 oz) per stroke

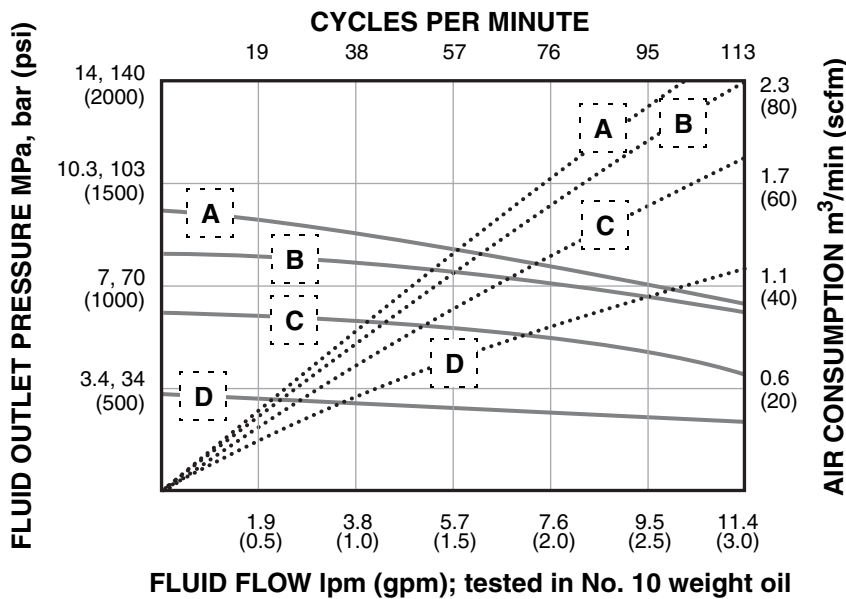

Key

A = 0.7 MPa, 7 bar (100 psi)
B = 0.6 MPa, 6.3 bar (90 psi)
C = 0.5 MPa, 4.9 bar (70 psi)
D = 0.3 MPa, 2.8 bar (40 psi)
Fluid Flow curves (solid lines) slope down, from left to right
Air Consumption curves (dotted lines) slope up, from left to right

Part Nos. 233753 and 233819, 20:1 Ratio, 35 cc (1.2 oz) per stroke

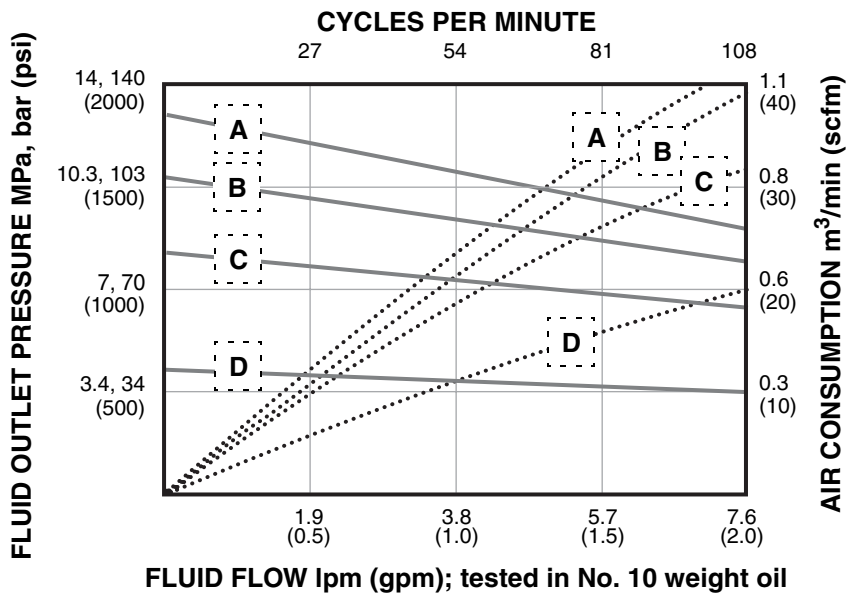

Key

A = 0.7 MPa, 7 bar (100 psi)
B = 0.6 MPa, 6.3 bar (90 psi)
C = 0.5 MPa, 4.9 bar (70 psi)
D = 0.3 MPa, 2.8 bar (40 psi)
Fluid Flow curves (solid lines) slope down, from left to right
Air Consumption curves (dotted lines) slope up, from left to right

Part Nos. 233754 and 233820, 30:1 Ratio, 20 cc (0.7 oz) per stroke

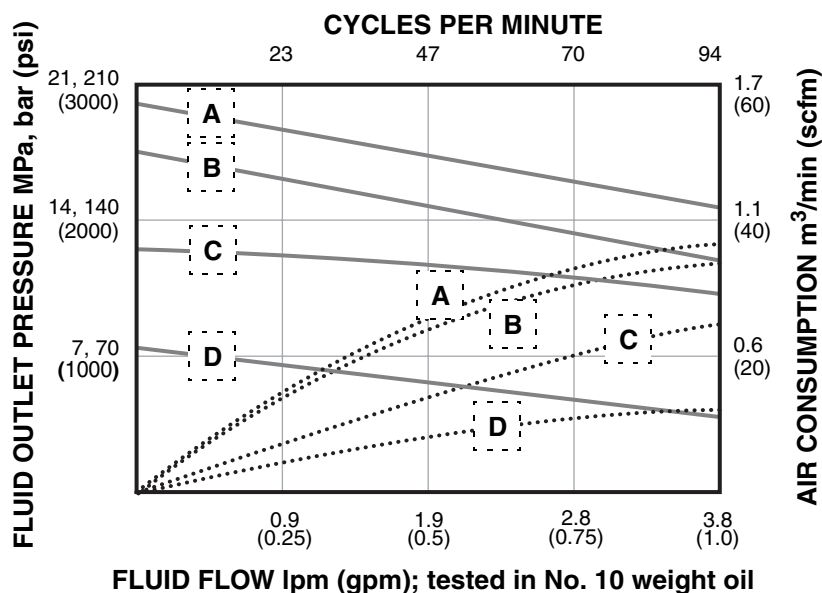

Key

A = 0.7 MPa, 7 bar (100 psi)
B = 0.6 MPa, 6.3 bar (90 psi)
C = 0.5 MPa, 4.9 bar (70 psi)
D = 0.3 MPa, 2.8 bar (40 psi)
Fluid Flow curves (solid lines) slope down, from left to right
Air Consumption curves (dotted lines) slope up, from left to right

Part Nos. 233755 and 233821, 30:1 Ratio, 50 cc (1.7 oz) per stroke

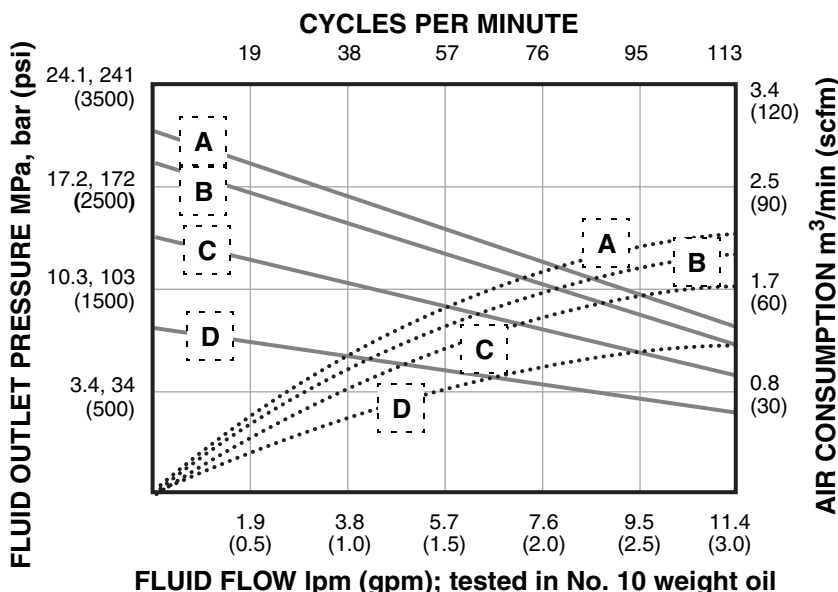

Key

A = 0.7 MPa, 7 bar (100 psi)
B = 0.6 MPa, 6.3 bar (90 psi)
C = 0.5 MPa, 4.9 bar (70 psi)
D = 0.3 MPa, 2.8 bar (40 psi)
Fluid Flow curves (solid lines) slope down, from left to right
Air Consumption curves (dotted lines) slope up, from left to right

Part Nos. 233756 and 233822, 40:1 Ratio, 35 cc (1.2 oz) per stroke

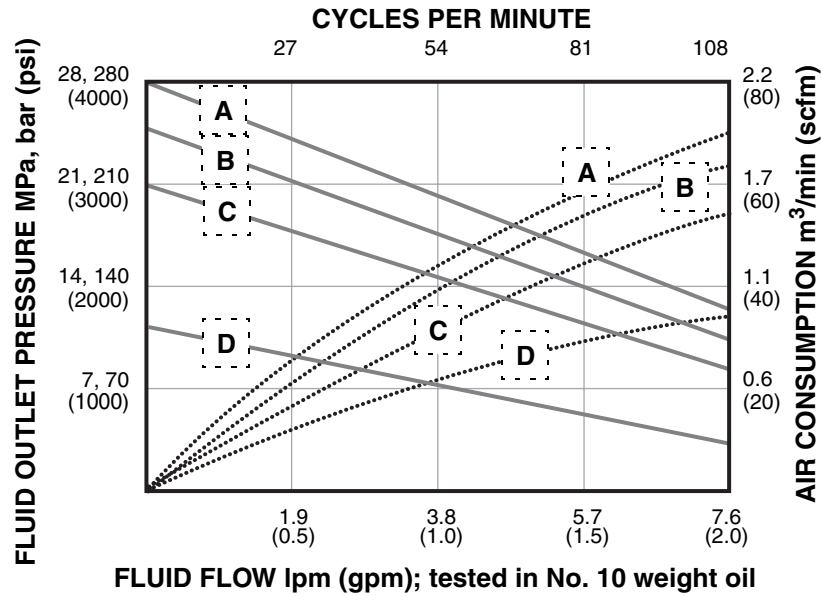

Key

A = 0.7 MPa, 7 bar (100 psi)
B = 0.6 MPa, 6.3 bar (90 psi)
C = 0.5 MPa, 4.9 bar (70 psi)
D = 0.3 MPa, 2.8 bar (40 psi)
Fluid Flow curves (solid lines) slope down, from left to right
Air Consumption curves (dotted lines) slope up, from left to right

Dimensions

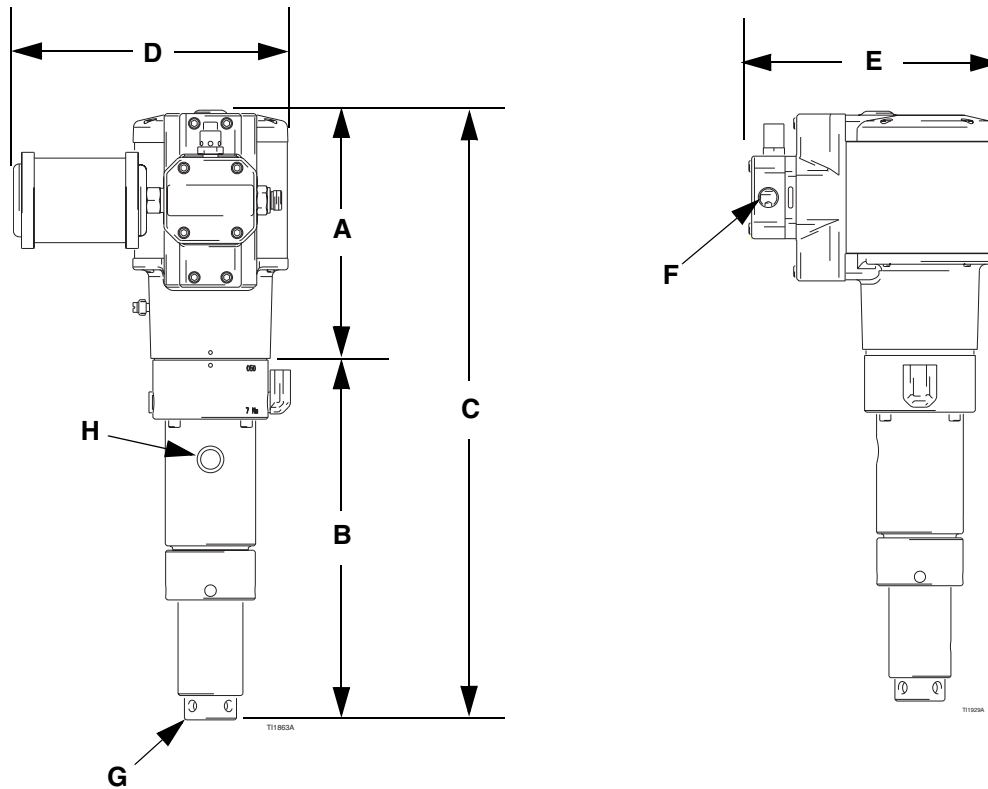

Pump Model	Weight kg (lb)	A cm (in.)	B cm (in.)	C cm (in.)	D cm (in.)	E cm (in.)	F: Air Inlet Size	G: Fluid Inlet Size	H: Fluid Outlet Size
233752	12.6 (28)	21.4 (8.4)	31.4 (12.4)	52.8 (20.8)	10.7 (4.2)	22.0 (8.7)	15.5 mm bore	M26 x 1.5(f)	3/8 bspp(f)
233753	12.2 (27)	21.4 (8.4)	31.4 (12.4)	52.8 (20.8)	10.7 (4.2)	22.0 (8.7)	15.5 mm bore	M26 x 1.5(f)	3/8 bspp(f)
233754	11.7 (26)	21.4 (8.4)	31.4 (12.4)	52.8 (20.8)	10.7 (4.2)	22.0 (8.7)	15.5 mm bore	M26 x 1.5(f)	3/8 bspp(f)
233755	14.9 (33)	21.4 (8.4)	31.4 (12.4)	52.8 (20.8)	13.2 (5.2)	27.0 (10.6)	15.5 mm bore	M26 x 1.5(f)	3/8 bspp(f)
233756	14.4 (32)	21.4 (8.4)	31.4 (12.4)	52.8 (20.8)	13.2 (5.2)	27.0 (10.6)	15.5 mm bore	M26 x 1.5(f)	3/8 bspp(f)
233818	17.1 (38)	21.4 (8.4)	34.2 (13.5)	55.6 (21.9)	10.7 (4.2)	22.0 (8.7)	1/4 npt(m)	3/4 npt(m)	3/8 npt(m)
233819	12.2 (27)	21.4 (8.4)	34.2 (13.5)	55.6 (21.9)	10.7 (4.2)	22.0 (8.7)	1/4 npt(m)	3/4 npt(m)	3/8 npt(m)
233820	11.7 (26)	21.4 (8.4)	34.2 (13.5)	55.6 (21.9)	10.7 (4.2)	22.0 (8.7)	1/4 npt(m)	3/4 npt(m)	3/8 npt(m)
233821	14.9 (33)	21.4 (8.4)	34.2 (13.5)	55.6 (21.9)	13.2 (5.2)	27.0 (10.6)	1/4 npt(m)	3/4 npt(m)	3/8 npt(m)
233822	14.4 (32)	21.4 (8.4)	34.2 (13.5)	55.6 (21.9)	13.2 (5.2)	27.0 (10.6)	1/4 npt(m)	3/4 npt(m)	3/8 npt(m)
245639*	6.1 (13.6)	n/a	31.2 (12.3)	n/a	n/a	n/a	n/a	M26 x 1.5(f)	3/8 bspp(f)
245640*	6.6 (14.7)	n/a	31.2 (12.3)	n/a	n/a	n/a	n/a	M26 x 1.5(f)	3/8 bspp(f)
245641*	7.3 (16.3)	n/a	31.2 (12.3)	n/a	n/a	n/a	n/a	M26 x 1.5(f)	3/8 bspp(f)

* 245639, 245640, and 245641 are ECOMIX Displacement Pumps only.

Graco Warranty

Graco warrants all equipment referenced in this document which is manufactured by Graco and bearing its name to be free from defects in material and workmanship on the date of sale to the original purchaser for use. With the exception of any special, extended, or limited warranty published by Graco, Graco will, for a period of twelve months from the date of sale, repair or replace any part of the equipment determined by Graco to be defective. This warranty applies only when the equipment is installed, operated and maintained in accordance with Graco's written recommendations.

This warranty does not cover, and Graco shall not be liable for general wear and tear, or any malfunction, damage or wear caused by faulty installation, misapplication, abrasion, corrosion, inadequate or improper maintenance, negligence, accident, tampering, or substitution of non-Graco component parts. Nor shall Graco be liable for malfunction, damage or wear caused by the incompatibility of Graco equipment with structures, accessories, equipment or materials not supplied by Graco, or the improper design, manufacture, installation, operation or maintenance of structures, accessories, equipment or materials not supplied by Graco.

This warranty is conditioned upon the prepaid return of the equipment claimed to be defective to an authorized Graco distributor for verification of the claimed defect. If the claimed defect is verified, Graco will repair or replace free of charge any defective parts. The equipment will be returned to the original purchaser transportation prepaid. If inspection of the equipment does not disclose any defect in material or workmanship, repairs will be made at a reasonable charge, which charges may include the costs of parts, labor, and transportation.

THIS WARRANTY IS EXCLUSIVE, AND IS IN LIEU OF ANY OTHER WARRANTIES, EXPRESS OR IMPLIED, INCLUDING BUT NOT LIMITED TO WARRANTY OF MERCHANTABILITY OR WARRANTY OF FITNESS FOR A PARTICULAR PURPOSE.

Graco's sole obligation and buyer's sole remedy for any breach of warranty shall be as set forth above. The buyer agrees that no other remedy (including, but not limited to, incidental or consequential damages for lost profits, lost sales, injury to person or property, or any other incidental or consequential loss) shall be available. Any action for breach of warranty must be brought within two (2) years of the date of sale.

GRACO MAKES NO WARRANTY, AND DISCLAIMS ALL IMPLIED WARRANTIES OF MERCHANTABILITY AND FITNESS FOR A PARTICULAR PURPOSE, IN CONNECTION WITH ACCESSORIES, EQUIPMENT, MATERIALS OR COMPONENTS SOLD BUT NOT MANUFACTURED BY GRACO. These items sold, but not manufactured by Graco (such as electric motors, switches, hose, etc.), are subject to the warranty, if any, of their manufacturer. Graco will provide purchaser with reasonable assistance in making any claim for breach of these warranties.

In no event will Graco be liable for indirect, incidental, special or consequential damages resulting from Graco supplying equipment hereunder, or the furnishing, performance, or use of any products or other goods sold hereto, whether due to a breach of contract, breach of warranty, the negligence of Graco, or otherwise.

FOR GRACO CANADA CUSTOMERS

The Parties acknowledge that they have required that the present document, as well as all documents, notices and legal proceedings entered into, given or instituted pursuant hereto or relating directly or indirectly hereto, be drawn up in English. Les parties reconnaissent avoir convenu que la rédaction du présente document sera en Anglais, ainsi que tous documents, avis et procédures judiciaires exécutés, donnés ou intentés, à la suite de ou en rapport, directement ou indirectement, avec les procédures concernées.

Graco Phone Numbers

TO PLACE AN ORDER, contact your Graco distributor, or call this number to identify the distributor closest to you:

1-800-328-0211 Toll Free

612-623-6921

612-378-3505 Fax

*All written and visual data contained in this document reflects the latest product information available at the time of publication.
Graco reserves the right to make changes at any time without notice.*

This manual contains English. MM 309462

Graco Headquarters: Minneapolis

International Offices: Belgium, China, Japan, Korea

GRACO INC. P.O. BOX 1441 MINNEAPOLIS, MN 55440-1441

www.graco.com

04/2002, Revised 3/2007