

Repair

MAGNUM[™]
by GRACO[®]



Airless Sprayer

309477 rev. G

US Patent 6,752,067
Europe Patent 1 208 287
Korean Patent 10-0668583

*- For portable spray applications of architectural paints and coatings -
(Specifications, page 3)*



Important Safety Instructions

Read all warnings and instructions in this manual. Save these instructions.

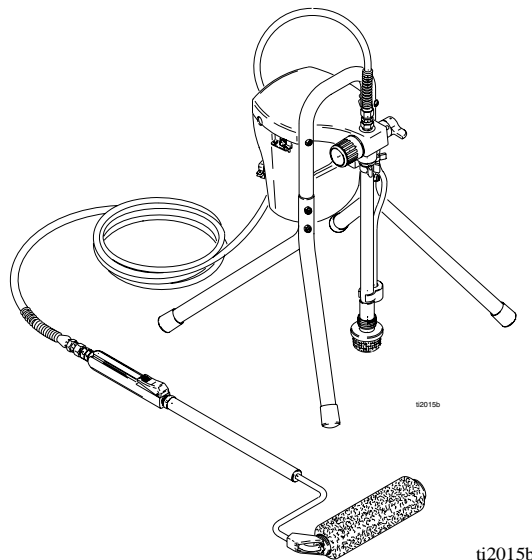

dx Pressure Roller/Spray System
Models 232736, 232737, 232738 - Series B

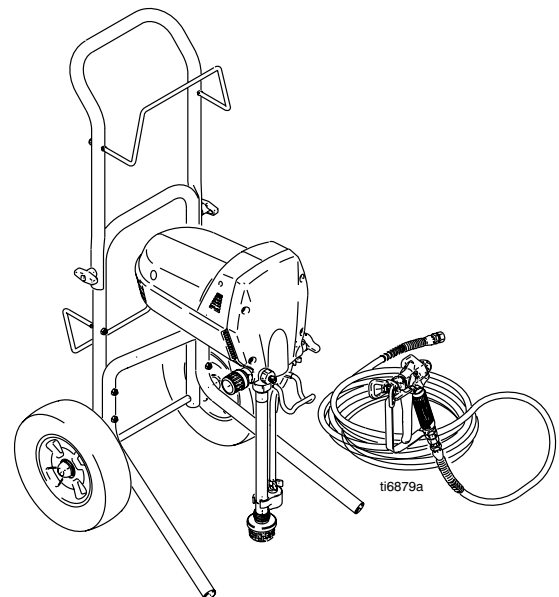

XR9 Sprayer
Models 232751, 232752, 232753 - Series A,B, C

Related Manuals

dx Pressure Roller Operation:	3W9470, 3X9470, 3Y9470, 3Z9470
XR9 Operation:	3W9478, 3X9478, 3Y9478, 3Z9478
SG3 Gun:	309097





PROVEN QUALITY. LEADING TECHNOLOGY.

Contents

Manual Conventions	3
Specifications	3
Warnings	4
Pressure Relief Procedure	6
Grounding and Electrical Requirements	7
Thermal Overload	7
General Repair Information	8
Basic Troubleshooting	9
Advanced Troubleshooting	11
General Problem: Motor Does Not Operate	11
General Problem: Circuit Breaker is Tripping	13
General Problem: Erratic Motor Operation	14
General Problem: Low or Fluctuating Output	15
General Problem: No Output	17
General Problem: Excessive Pressure Build Up	17
List of Kits	18
Motor Diagnostics	19
Control Board Diagnostics	20
Pump Diagnostics	20
Pump Service	20
Parts	21
dx Pressure Roller/Spray System	21
Pressure Roller Assembly	23
Parts	24
XR9 Spray System	24
XR9 Spray System Labels	27
Technical Data	29
Graco Warranty	30

Manual Conventions

 WARNING
 Hazard Symbol
WARNING: a potentially hazardous situation which, if not avoided, could result in death or serious injury.
Warnings in the instructions usually include a symbol indicating the hazard. Read the general Warnings section for additional safety information.

CAUTION
CAUTION: a potentially hazardous situation which, if not avoided, may result in property damage or destruction of equipment.

Note







Additional helpful information.







Specifications

This equipment is not intended for use with flammable or combustible materials used in places such as cabinet shops or other “factory”, or fixed locations. If you intend to use this equipment in this type of application, you must comply with NFPA 33 and OSHA requirements for the use of flammable and combustible materials.

Warnings

The following are general related to the safe setup, grounding, use, maintenance, and repair of this equipment. Additional, more specific warnings may be found throughout the text of this manual, where applicable.

 WARNING	
	<p>FIRE AND EXPLOSION HAZARD</p> <p>Flammable fumes, such as solvent and paint fumes, in work area can ignite or explode. To help prevent fire and explosion:</p> <ul style="list-style-type: none"> • Use equipment only in well ventilated area. • Eliminate all ignition sources; such as pilot lights, cigarettes, portable electric lamps, and plastic drop cloths (potential static arc). • When flammable liquid is used in or near the sprayer or for flushing or cleaning, keep sprayer at least 20 feet (6 m) away from explosive vapors. • Do not clean with materials having flash points lower than 70°F (21°C). Use water-based materials or mineral spirits type material only. For complete information about your fluid, request the MSDS from the fluid distributor or retailer. • Keep work area free of debris, including solvent, rags and gasoline. • Do not plug or unplug power cords or turn lights on or off when flammable fumes are present. • Ground equipment and conductive objects in work area. See Grounding instructions. • If there is static sparking or you feel a shock, stop operation immediately. Do not use equipment until you identify and correct the problem. • Keep a working fire extinguisher in the work area.
	<p>ELECTRIC SHOCK HAZARD</p> <p>Improper grounding, setup, or usage of the system can cause electric shock.</p> <ul style="list-style-type: none"> • Turn off and disconnect power cord before servicing equipment. • Use only grounded electrical outlets. • Use only 3-wire extension cords. • Ensure ground prongs are intact on sprayer and extension cords.
	<p>SKIN INJECTION HAZARD</p> <p>High-pressure fluid from gun, hose leaks, or ruptured components will pierce skin. This may look like just a cut, but it is a serious injury that can result in amputation. Get immediate surgical treatment.</p> <ul style="list-style-type: none"> • Do not point gun at anyone or at any part of the body. • Do not put your hand over the spray tip. • Do not stop or deflect leaks with your hand, body, glove, or rag. • Engage trigger lock when not spraying. • Follow Pressure Relief Procedure in this manual, when you stop spraying and before cleaning, checking, or servicing equipment.

 WARNING	
	<p>EQUIPMENT MISUSE HAZARD</p> <p>Misuse can cause death or serious injury.</p> <ul style="list-style-type: none"> • Do not exceed the maximum working pressure or temperature rating of the lowest rated system component. See Technical Data in all equipment manuals. • Use fluids and solvents that are compatible with equipment wetted parts. See Technical Data in all equipment manuals. Read fluid and solvent manufacturer's warnings. • Check equipment daily. Repair or replace worn or damaged parts immediately. • Do not alter or modify equipment. • Use equipment only for its intended purpose. Call your Graco distributor for information. • Route hoses and cables away from traffic areas, sharp edges, moving parts, and hot surfaces. • Do not kink or over bend hose or use hoses to pull equipment. • Keep children and animals away from work area. • Comply with all applicable safety regulations.
	<p>BURN HAZARD</p> <p>Equipment surfaces and fluid that's heated can become very hot during operation. To avoid severe burns, do not touch hot fluid or equipment. Wait until equipment/fluid has cooled completely.</p>
	<p>PRESSURIZED ALUMINUM PARTS HAZARD</p> <p>Do not use 1,1,1-trichloroethane, methylene chloride, other halogenated hydrocarbon solvents or fluids containing such solvents in pressurized aluminum equipment. Such use can cause serious chemical reaction and equipment rupture, and result in death, serious injury, and property damage.</p>
	<p>TOXIC FLUID OR FUMES HAZARD</p> <p>Toxic fluids or fumes can cause serious injury or death if splashed in the eyes or on skin, inhaled, or swallowed.</p> <ul style="list-style-type: none"> • Read MSDS's to know the specific hazards of the fluids you are using. • Store hazardous fluid in approved containers, and dispose of it according to applicable guidelines.
	<p>PERSONAL PROTECTIVE EQUIPMENT</p> <p>You must wear appropriate protective equipment when operating, servicing, or when in the operating area of the equipment to help protect you from serious injury, including eye injury, inhalation of toxic fumes, burns, and hearing loss. This equipment includes but is not limited to:</p> <ul style="list-style-type: none"> • Protective eye wear • Clothing and respirator as recommended by the fluid and solvent manufacturer • Gloves • Hearing protection

Pressure Relief Procedure

 To help prevent injuries, follow this procedure when you stop spraying and before you service or clean the sprayer, remove parts or repair leaks.

1. Turn OFF power switch.

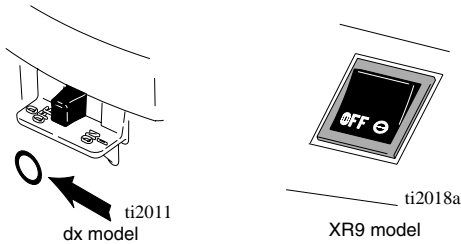

2. Unplug sprayer.

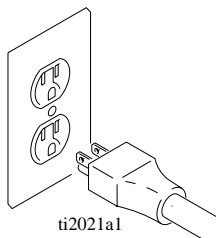

3. Turn Prime/Spray valve to PRIME. Trigger gun to relieve pressure in hose.



4. Engage trigger safety.

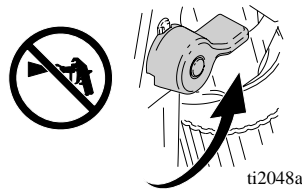

 Leave Prime/Spray valve in PRIME position until you are ready to spray again.

If you suspect the spray tip or hose is completely clogged or that pressure has not been fully relieved after following the above steps, **VERY SLOWLY** loosen the tip guard retaining nut or hose end coupling to relieve pressure gradually. Then loosen it completely. Clear tip or hose obstruction.

Grounding and Electrical Requirements

This sprayer requires 220-240 VAC, 50/60 Hz, 10A circuit with a grounding receptacle. Do not use an outlet that is not grounded.

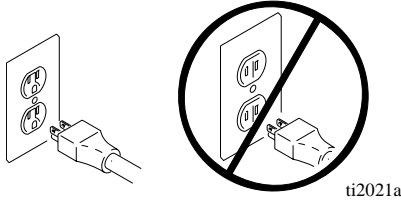

Do not use the sprayer if the electrical cord has a damaged ground prong. Only use an extension cord with an undamaged 3-prong plug.



Only use an extension cord with an undamaged 3-prong plug. Recommended extension cords for use with this sprayer are:

- 15 m (49.2 ft) 1.0 mm²
- 30 m (88.4 ft) 1.5 mm²
- 50 m (164.0 ft) 2.5 mm²

 Smaller-gauge or longer extension cords may reduce sprayer performance.

Spray gun: ground through connection to a properly grounded fluid hose and pump.

Fluid supply container: follow local code.

Solvent pails used when flushing: follow local code. Use only conductive metal pails, placed on a grounded surface such as concrete. Do not place the pail on a nonconductive surface, such as paper or cardboard, which interrupts grounding continuity.

Grounding the metal pail: connect a ground wire to the pail by clamping one end to pail and other end to ground such as a water pipe.

To maintain grounding continuity when flushing or relieving pressure: hold metal part of the spray gun firmly to the side of a grounded metal pail, then trigger the gun.

Thermal Overload

Motor has a thermal overload switch to shut itself down if overheated.



WARNING

To reduce risk of injury from motor starting unexpectedly when it cools, always turn power switch OFF if motor shuts down.

General Repair Information

WARNING



Page 4.

- Keep all screws, nuts, washers, gaskets, and electrical fittings removed during repair procedures. These parts are not normally provided with replacement assemblies.
- Test repair after problem is corrected.
- If sprayer does not operate properly, review repair procedure to verify you did it correctly. See Basic Troubleshooting, page 9 and Advanced Troubleshooting, page 11.
- Overspray may build up in the air passages. Remove any overspray and residue from the air passages and openings in the enclosures whenever you service the sprayer.

- Do not operate the sprayer without the enclosure. Replace if damaged. Enclosures direct cooling air around the motor to prevent overheating. They also reduce the risk of burns, fire or explosion.

CAUTION

Do not run sprayer dry for more than 30 seconds. Doing so could damage pump packings.

Protect internal drive parts of this sprayer from water. Openings in enclosures allow for air cooling of mechanical parts and electronics inside. If water gets into these openings, the sprayer could malfunction or be permanently damaged.

Prevent pump corrosion and damage from freezing. Never leave water or water-based paint in sprayer when it is not in use in cold weather. Freezing fluids can seriously damage sprayer.

Store sprayer with mineral spirits/paint thinner or Graco Pump Armor to protect equipment during storage.

Basic Troubleshooting

The following troubleshooting guidelines are included here as preemptive measures against **Advanced Troubleshooting**, page 11.

Problem	Cause	Solution
Power switch is on and sprayer is plugged in, but motor does not run and pump does not cycle	Pressure is set at zero pressure	Turn pressure control knob counterclockwise to increase pressure setting.
	Motor control is damaged	See Motor Does Not Operate , page 11.
	Electrical outlet is not providing power	<ul style="list-style-type: none"> Try a different outlet or plug in something that you know is working to test outlet Reset building circuit breaker or replace fuse
	Extension cord is damaged	Replace extension cord. See Grounding and Electrical Requirements , page 7.
	Sprayer electrical cord is damaged	Check for broken insulation or wires. Replace electrical cord if damaged.
	Paint is frozen or hardened in pump	See Motor Does Not Operate , page 11.
Pump does not prime	Spray-PRIME valve is in SPRAY position	Turn Prime/Spray valve to PRIME position (pointing down).
	Inlet screen is clogged or suction tube is not immersed	Clean debris off inlet screen and make sure suction tube is at bottom of paint pail.
	Balls in check valve are stuck or check valves are damaged	Clean or replace check valves. See Pump Service , page 20. Do not store in water.
	Suction tube is leaking	Tighten suction tube connection. Inspect for other cracks or vacuum leaks.
Spray gun stopped spraying	Spray tip is plugged	Unplug spray tip. Manual 309097.
Pump cycles but does not build up pressure	Pump is not primed	Prime pump.
	Inlet screen is clogged or suction tube is not immersed	Clean debris off inlet screen and make sure suction tube is at bottom of paint pail.
	Paint pail is empty	Refill paint pail and reprime sprayer.
	Suction tube is leaking	Tighten suction tube connection. Inspect for other cracks or vacuum leaks.
	Pump check valves are dirty or damaged. (Usually only one valve)	Clean or replace check valves. See Pump Service , page 20.
	Prime/Spray valve is worn or obstructed with debris	Check Prime/Spray valve for debris trapped on seat and worn parts. Torque to 21 N·m (185 in-lb).
Pump cycles but paint only dribbles or spurts when spray gun is triggered	Pressure is set too low	Slowly turn pressure control knob clockwise to increase pressure setting. Sprayer should develop more pressure.
	Spray tip is plugged	Unplug spray tip. Manual 309097.
	InstaClean fluid filter is clogged (XR9 only)	Clean or replace InstaClean fluid filter.
	Spray gun fluid filter is clogged	Clean or replace spray gun fluid filter.

Problem	Cause	Solution
Spray pattern is inconsistent or is leaving stripes	Pressure is set too low	Turn pressure control knob clockwise to increase pressure.
	Spray tip is worn beyond capability of sprayer	Replace spray tip.
Pressure is set at maximum but cannot achieve a good spray pattern	Spray tip is too big for sprayer	Select smaller spray tip.
	Spray tip is worn beyond capability of sprayer	Replace spray tip.
	Extension cord is too long or not heavy enough gauge	Replace extension cord. Grounding and Electrical Requirements , page 7.
	Spray gun fluid filter is clogged	Clean or replace spray gun fluid filter.
	InstaClean fluid filter is clogged (XR9 only)	Clean or replace InstaClean fluid filter.
	Inlet screen is clogged	Clean debris off inlet screen.
	Pump valves are worn	See Low or Fluctuating Output , page 15.
Motor is hot and runs intermittently. This is NOT a thermal overload condition. Motor automatically shuts off due to excessive heat. Damage can occur if cause is not corrected. Thermal Overload , page 7.	Vent holes in enclosure are plugged or sprayer is covered	Keep vent holes clear of obstructions and overspray and keep sprayer open to air.
	Extension cord is too long or not a heavy enough gauge	Replace extension cord. See Grounding and Electrical Requirements , page 7.
	Unregulated electrical generator being used has excessive voltage	Use electrical generator with a proper voltage regulator. Sprayer requires 220-240 VAC, 50/60 Hz, 1500-Watt generator.
	Sprayer was operated at high pressure with very small tip which causes frequent motor starts and excessive heat build up	Decrease pressure setting or increase tip size.
Building circuit breaker opens after sprayer operates for 5 to 10 minutes.	Too many appliances are plugged in on same circuit.	Free up circuit (unplug things), or use a less busy circuit.
	Sprayer electrical cord is damaged.	Check broken insulation or wires. Replace electrical cord if damaged.
Fan pattern varies dramatically while spraying OR Sprayer does not turn on promptly when resuming spraying	Pressure control switch is worn and causing excessive pressure variation	Replace pressure control knob using Pressure Control Switch Kit , page 18.
Cannot trigger spray gun	Spray gun trigger safety lever is in SAFETY ON position	Rotate trigger safety lever to SAFETY OFF position.
Spray comes out of spray gun in two thick streams	Reversible spray tip is in UNCLOG position	Rotate arrow-shaped handle on spray tip so it points forward in SPRAY position.
Paint is coming out of pressure control switch	Pressure control switch is worn	Replace pressure control using Pressure Control Switch Kit , page 18.
Spray-PRIME valve actuates automatically relieving pressure through drain tube	System is over pressurizing	See Excessive Pressure Build Up , page 17.
Paint leaks down outside of pump	Pump packings are worn	Replace pump packings. See Pump Service , page 20.

Advanced Troubleshooting

 **WARNING**

Page 4.

General Problem: Motor Does Not Operate

Specific Problem	Cause	Solution
Power switch is on and sprayer is plugged in; pump does not cycle	See Basic Troubleshooting , page 9	
Basic mechanical problems	Paint is frozen or hardened in pump	<p>Unplug sprayer from electrical outlet.</p> <p>If paint is frozen in sprayer:</p> <ul style="list-style-type: none"> Do NOT try to start sprayer until completely thawed or you may damage the motor, control board, and/or drivetrain. <ol style="list-style-type: none"> Turn OFF power switch Place sprayer in warm area for several hours Plug in and turn on sprayer Slowly increase pressure until motor starts <p>If paint hardened in sprayer:</p> <ol style="list-style-type: none"> Replace pump packings Remove all residue from valves <p>Pump Service, page 20.</p>
	Motor is damaged	Remove gear and try to rotate motor shaft by hand. See Motor Diagnostics , page 19. If shaft will not turn, replace motor using Motor Kit , page 18.
	Yoke is broken because pump is locked up due to dried paint or worn packings (XR9 only)	<p>Repair or replace using Gear/Yoke Kit, page 18.</p> <p>Repair pump, page 20.</p>

Specific Problem	Cause	Solution
Basic electrical problems	Motor overheated	Allow motor to cool for 30 minutes. Retry.
	Electrical outlet is damaged	Reset building circuit breaker or replace building fuse. Try another outlet. Check electric supply with volt meter. Meter must read 200-260V AC. If voltage is too high, do not plug sprayer in until outlet is corrected.
	Control board leads are improperly fastened or improperly mated	Replace any loose terminals. Make sure all leads and harnesses are firmly connected. Check pressure control harness connection on front side of drive housing. Clean control board terminals. Securely reconnect leads.
	Motor brushes are worn.	Check length of BOTH brushes (brushes do not wear evenly on both sides of the motor). Brush length must be 6.4mm (0.25 in). If brushes are worn replace motor using Motor Kit , page 18.
	Motor armature commutator damaged	Check for burn spots, gouges and extreme roughness. Have motor shop resurface commutator if possible, or replace motor using Motor Kit , page 18.
	Motor armature shorting	Check for shorts using armature tester (growler) or perform spin test, Motor Diagnostic , page 19. If shorts are evident, replace motor using Motor Kit , page 18.
	Control board damaged. CAUTION: Do not perform control board diagnostics until you have determined the armature is good. A bad armature can burn out a good control board.	See Control Board Diagnostics , page 19. Replace control board if damaged using Control Board Kit , page 18.
Sprayer Wiring Problems NOTE: Remove enclosure mounting screws and pull enclosure away from drive housing. Take care not to pull on leads from electrical cord and power switch.	Sprayer electrical cord damaged	<ol style="list-style-type: none"> 1. Unplug sprayer electrical cord. 2. Disconnect black electrical cord wire at power switch 3. Unplug in-line connection white cord wire. 4. Plug in electrical cord 5. Test voltage between black and white wires. Meter must read 200-260 V AC. 6. Replace electrical cord if no voltage.
	Sprayer power switch damaged	<ol style="list-style-type: none"> 1. Unplug sprayer electrical cord. 2. Disconnect black control board wire at power switch. 3. Unplug in-line connection white cord wire. 4. Plug in electrical cord. 5. Turn power switch ON. 6. Test voltage between open terminal of power switch and white electrical cord wire. Meter must read 200-260 V AC. 7. Replace power switch if no voltage.

Specific Problem	Cause	Solution
Sprayer Wiring Problems (cont.)	Motor thermal overload cutoff switch damaged. Thermal Overload , page 7.	<ol style="list-style-type: none"> 1. Unplug sprayer electrical cord. 2. Remove motor harness from control card 3. Check for continuity between yellow leads or motor harness. 4. If thermal relief switch is open (no continuity) allow motor to cool. 5. If switch remains open after motor cools, replace motor using Motor Kit, page 18. 6. If thermal relief switch closes after motor cools, find correct cause of overheating.
	Terminals are damaged or loose	Replace any damaged terminals. Make sure all terminal connections are tight.

General Problem: Circuit Breaker is Tripping

Specific Problem	Cause	Solution
Building circuit breaker opens as soon as sprayer is turned on	Sprayer electrical wiring is pinched or insulation is damaged.	Repair or replace any damaged wiring or terminals. Securely reconnect wires.
	Wires between pressure control switch and control board are pinched	
	Motor armature is shorting	Check for shorts using armature tester (growler) or perform spin test, Motor Diagnostics , page 19. If shorts are evident, replace motor using Motor Kit , page 18.
	Control board is damaged. CAUTION: Do not perform control board diagnostics until you have determined the armature is good. A bad motor armature can burn out a good motor control board.	See Control Board Diagnostics , page 19. Replace control board if damaged using Control Board Kit , page 18.

Specific Problem	Cause	Solution
Building circuit breaker opens as soon as sprayer is plugged into outlet and sprayer is NOT turned on. NOTE: Remove enclosure mounting screws and pull enclosure away from drive housing. Take care not to pull on leads from electrical cord and power switch.	Sprayer electrical cord is damaged	1. Unplug sprayer electrical cord. 2. Disconnect black electrical cord wire at power switch 3. Unplug in-line connection white cord wire. 4. Plug in electrical cord 5. Test voltage between black and white wires. Meter must read 200-260 V AC. 6. Replace electrical cord if no voltage.
	Sprayer power switch damaged	1. Unplug sprayer electrical cord. 2. Disconnect black control board wire at power switch. 3. Check resistance of switch with ohmmeter. 4. Reading must be infinity with power switch OFF. 5. Reading must be zero with power switch ON. 6. Replace power switch if damaged.
	Also "Basic Electrical Problems" and "Sprayer Wiring Problems", page 12.	

General Problem: Erratic Motor Operation

Specific Problem	Cause	Solution
Sprayer quits after running for 5 to 10 minutes	Electrical outlet is damaged	Reset building circuit breaker or replace building fuse.
	Electrical outlet supplying wrong voltage	Try another outlet. Check electric supply with volt meter. Meter must read 200-260 V AC. If voltage is too high, do not use outlet until corrected.
	Also "Basic Electrical Problems" and "Sprayer Wiring Problems", page 12.	
	Motor is overheating	"Motor is Hot", page 10.

General Problem: Low or Fluctuating Output

Specific Problem	Cause	Solution
Pump cycles, but output is low or surging	See Basic Troubleshooting , page 9.	
	Worn or obstructed pump valves	Check for worn pump valves as follows: <ol style="list-style-type: none"> 1. Prime sprayer with paint. 2. Trigger spray gun momentarily. 3. When spray gun trigger is released pump should cycle momentarily and stop. 4. If pump continues to cycle, pump valves may be worn or obstructed. 5. Pump Service, page 20.
	Prime/Spray valve is leaking	Check Prime/Spray valve for debris trapped on seat and for worn parts. Torque to 21 N•m (185 in-lb). Replace if parts are worn using Prime/Spray Drain Valve Kit , page 18.
	Voltage from electrical outlet is too low. Low voltages reduce sprayer performance.	Check voltage of outlet. Meter must read 200-260 V AC. Reset building circuit breaker or replace building fuse. Repair electrical outlet or try another outlet.
	Extension cord is too long or not heavy enough gauge	Replace extension cord. Grounding and Electrical Requirements , page 7.
	Leads from motor or pressure switch to control board are damaged, loose, pinched, or overheated	Be sure terminals are centered and firmly connected. Inspect for pinched wiring and wiring insulation and terminals for signs of overheating. Replace any loose terminals or damaged wiring. Securely reconnect terminals.
	Motor brushes are worn	Check length of BOTH brushes (brushes to not wear evenly on both sides of the motor). Brush length must be 6.4mm (0.25 in). If brushes are worn replace motor using Motor Kit , page 18.
	Motor brush springs are broken	If springs are broken replace motor using Motor Kit , page 18.
	Motor brushes are binding in brush holders	Clean brush holders. Remove carbon dust with small cleaning brush.
	Motor stops before sprayer reaches correct pressure (stall pressure is too low)	Replace pressure control using Pressure Control Switch Kit , page 18.
Motor armature shorted	Check for shorts using armature tester (growler) or perform spin test, Motor Diagnostics , page 19. If shorts are evident, replace motor using Motor Kit , page 18.	

Specific Problem	Cause	Solution
	Control board is damaged. CAUTION: Do not perform control board diagnostics until you have determined the armature is good. A bad motor can burn out a good control board.	See Control Board Diagnostics , page 19. If damaged replace control board using Control Board Kit , page 18.
Motor runs and pump cycles, but pressure does not build up	Intake valve ball or outlet valve ball is not seating properly	Remove and clean valves and check balls and seats for nicks; replace if necessary. Strain paint before spraying to remove particles that could clog pump. Pump Service , page 20.
	Pump packings are worn or damaged	Check for leaking around throat packing nut. Replace pump packings if there are leaks. Pump Service , page 20.
	Prime/Spray Valve leaking	Check Prime/Spray Valve for debris trapped on seat and for worn parts. Torque to 21 N•m (185 in-lb). If parts are worn, replace valve using Prime/Spray Drain Valve Kit , page 18.
Spray pattern has variations, pressure fluctuates excessively, or motor runs very slowly	Leads from motor or pressure switch to control board are damaged, loose or overheated	Be sure terminals are centered and firmly connected. Inspect wiring insulation and terminals for signs of overheating. Replace any loose terminals or damaged wiring. Securely reconnect terminals.
	Pressure control switch leads are pinched between pump and drive housing or between front cover and drive housing (XR9 only)	Make sure pressure control harness is routed behind pump, through retention clip and connected to control board connector on control board (connect with tab to right).
	Control board is damaged. CAUTION: Do not perform control board diagnostics until you have determined the armature is good. A bad armature can burn out a good control board.	See Control Board Diagnostics , page 19. If damaged, replace control board using Control Board Kit , page 18.
	Pressure control switch is damaged or worn out	Replace pressure control switch using Pressure Control Switch Kit , page 18.

General Problem: No Output

Specific Problem	Cause	Solution
Power switch is on and sprayer is plugged in but pump does not cycle	See Basic Troubleshooting, page 9.	
Motor runs but pump does not cycle	Gear and/or yoke are damaged (XR9 only)	Replace gear and yoke using Gear/Yoke Repair Kit , page 18.
Motor does not run	Water or paint entered pressure control switch or shorted control board	Clean out and/or dry out and retry. Replace if necessary using Pressure Control Switch Kit , page 18.

General Problem: Excessive Pressure Build Up

Specific Problem	Cause	Solution
Prime/Spray Valve actuates automatically, relieving pressure through drain tube.	Pressure control switch is worn	Replace pressure control switch using Pressure Control Switch Kit , page 18.
	Water or paint entered pressure control switch or shorted control board	Clean out and/or dry out and retry. Replace if necessary using Pressure Control Switch Kit , page 18.
	Control board failed	See Control Board Diagnostics , page 19. Replace damaged control board using Control Board Kit , page 18.

List of Kits

Kit Number	Models/Series	Kit Description
235014	All	Prime/Spray Drain Valve
243082	All	Inlet Strainer (or inlet of suction tube)
243090	XR9	Pump Repair (pump packing module)
245077	dx	Pump Inlet Valve Module
245070	XR9	Pump Inlet Valve Module
15A473	dx, XR9 Series A	Suction Tube
15D883	XR9 Series B, C	Suction Tube
15A475	All	Drain Tube
245076	dx	Pump Outlet Valve Module
243094	XR9	Pump Outlet Valve Module
244035	All	Drain Tube Diffuser
246286	All	Pressure Control Switch
245677	dx	Control Board
245665	XR9	Control Board
243231	XR9 Series A, B	Fan/Shroud/Brace
287770	XR9 Series C	Fan
245062	XR9	Shaft Gear/Yoke/Guides
245064	XR9	Front Cover (with ID label)
245667	XR9 Series A, B	Motor/Drive Housing (includes fan/shroud/brace)
287784	XR9 Series C	Motor/Drive Housing (includes fan)
245595	XR9 Series A, B	Enclosure (includes both sides, labels and screws)
287785	XR9 Series C	Enclosure (includes both sides, labels and screws)
245078	dx	Pump Repair
245646	dx	Motor Repair
245053	XR9	XR Pump Replacement (complete pump*) <i>* Does not include Pressure Control Switch 244267. Reuse pressure control switch from pump being replaced or order separately.</i>
245647	dx	Enclosure (includes labels and screws)
245678	dx	Cover (includes labels, bushings, and dowel pins)
245821	All	Gear Lubrication/Repair
248202	XR9	Lacquer Conversion (lacquer compatible suction tube and seals)

Motor Diagnostics

Check for electrical continuity in motor armature, windings and brush as follows:

If Motor Diagnostics reveal a damaged motor or if motor brushes are shorter than 6.4 mm (1/4 in.) or if the motor shaft cannot turn, replace the motor using **Motor Kit**, page 18.



Both Models

1. Relieve pressure.
2. Remove enclosure and disconnect motor leads from control card.
3. Connect standard 9V DC battery using test leads.

Motor and drive train should slowly rotate if motor functioning and drive train is free.

Setup (XR9 model only)

1. Relieve pressure.
2. Unplug electrical cord.
3. Remove right enclosure. Disconnect motor harness from control board.

4. Remove fan brace.
5. Remove four screws and front cover.
6. Remove yoke and guide rods (XR9 model only).
7. Remove gear.

Armature Short Circuit Spin Test (XR9 model only)

Quickly turn motor fan by hand. There should not be electrical shorts and fan should coast two or three revolutions before stopping. If fan does not spin freely, armature is shorted. Replace motor using **Motor Kit**, page 18.

Armature, Brushes and Motor Wiring Open Circuit Test (Continuity) (XR9 model only)

1. Connect red and black motor leads together with test lead.
2. Turn motor fan by hand, about two revolutions per second.
3. If there is an uneven resistance or no resistance, replace motor using **Motor Kit**, page 18.

Control Board Diagnostics



Check for motor problems before replacing control board. A damaged motor may burn out a good control card

Check for a damaged control board or pressure control switch as follows:



1. Relieve pressure.
2. Unplug electrical cord.
3. Remove four cover screws and front cover (XR9). Remove motor enclosure (dx).
4. Remove yoke and guide rods (XR9 model only).
5. Remove gear (XR9 model only).
6. Remove pressure control harness from control board. Using fingernail or tip of small, flat blade

screwdriver, press tab on right side connector to release.

7. Attach harness from a control board you know is functioning correctly to control board.



Pressure control switch does not have to be installed in pump.

8. Turn pressure control adjustment knob to maximum pressure setting.
9. Plug electrical cord into 220-240 V AC receptacle.
10. Turn power switch ON.
 - If motor runs, replace pressure switch. **Pressure Control Switch Kit**, page 18.
 - If motor does not run, replace control board repeat test. **Control Board Kit**, page 18.

Pump Diagnostics

CAUTION

When repairing or cleaning the pump, never submerge pump in water or allow fluid to enter pressure control.

When pump packings wear, paint begins to leak down outside of pump. Replace pump packings at the first sign of leaking or additional damage to drive train could occur. Use **Pump Repair Kit**, page 18.

Pump Service

CAUTION

When repairing or cleaning pump, never submerge pump in water or allow fluid to enter pressure control.

If sprayer continues to cycle (motor and pump run) when the spray gun trigger is released, or if performance is poor even with new spray tips and clean filters, the pump inlet or outlet valve may be obstructed or worn. If a pump is worn, replace it. **List of Kits**, page 18.

Parts

dx Pressure Roller/Spray System

Model 232736, 232737, 232738

Ref No.	Part No.	Description	Qty	Ref No.	Part No.	Description	Qty
2	243082	STRAINER	1		245727	CORD, Denmark	1
3	244035	DEFLECTOR, barbed	1		245728	CORD, Australia	1
5	15A473	TUBE, suction	1		245729	CORD, Sweden	1
12	15A475	TUBE, spray	1	58	241922	HOSE, paint, 1/4 in. x 25 ft	1
13	115489	CLAMP, drain tube	2	59	243238	GUN, spray, (models 232736 & 232737) includes manual 309097	1
15	15A680	FRAME, stand	1		243382	GUN, spray (model 232738) includes manual 309097	1
16	15H772	LEG, stand	2				
18	113955	SCREW, curved head	4	61▲	243308	KIT, label, warning	1
19	102040	NUT, locking	4	63	115477	SCREW, machine, pan head	9
23	246286	KIT, pressure switch repair	1	64	196574	FITTING, drain	1
30	224807	CAM, drain valve	1	69	115648	VALVE, shutoff, power flush	1
31	235014	KIT, valve repair	1	70	117219	SCREW, M3, washerhead	2
32	111600	DRIVE PIN, drain valve	1	71	115632	CLAMP, power cord	1
38	187625	HANDLE, drain valve	1	72	245648	FILTER, EMI	1
41	245647	KIT, motor enclosure	1	73	15A467	BRACKET, filter	1
42	245678	KIT, cover	1	75	245589	ROLLER ACCESSORY (manual 3W9470, 3X9470, 3Y9470, 3Z9470)	1
43	117220	PLUG, snap in	1				
44	245149	KIT, gear (includes 2 gears and connecting rod)	1	76	245590	VALVE, roller (manual 3W9470, 3X9470, 3Y9470, 3Z9470)	1
50	245078	KIT, pump repair	1	77	246187	ADAPTER, Geka to 3/4 in. GHT (not shown)	1
51	245677	KIT, control board 230V	1				
52	245646	KIT, motor repair 230V	1	78	245856	KIT, pressure gage (not shown) (included with models 232736 and 232737 only).	1
53	245076	KIT, outlet valve	1				
54	245077	KIT, inlet valve	1				
55	116295	CLAMP, spring, .88 dia.	1				
56	115478	SCREW, machine, pan head	2				
57	245725	CORD, Schuko CEE7/7	1				
	245726	CORD, Italy	1				

▲ Replacement Danger and Warning labels, tags, and cards are available at no cost.

dx Pressure Roller/Spray System

Model 232736, 232737, 232738

 Apply light coat of lithium-based grease

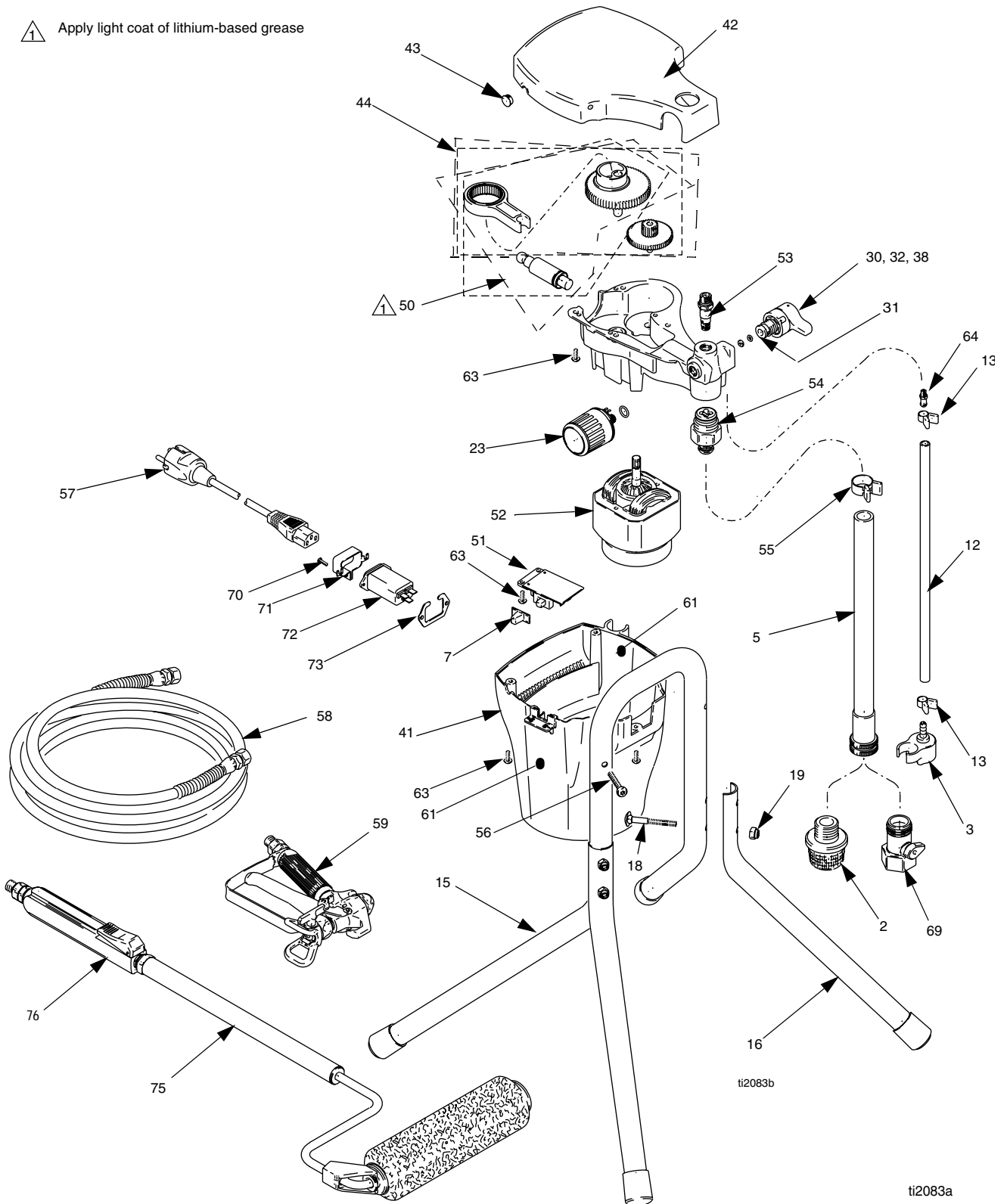

Pressure Roller Assembly

Model 245589

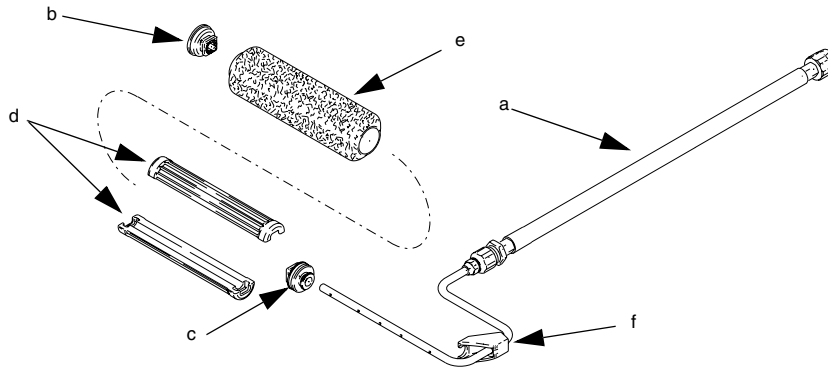

75a	15A586	TUBE, extension	1
75b	245999	CAP, end, roller	1
75c	246277	CAP, end, roller	1
75d	15B065	CORE, roller	1
75e	107590	BRUSH, roller, 9 in. x 1/2 in. nap	1
75f	197106	CLIP, roller	1

Parts

XR9 Spray System

Model 232751, 232752, 232753

Ref No.	Part No.	Description	Qty	Ref No.	Part No.	Description	Qty
1	195126	PUMP, housing	1	71	15D650	HOSE, rack	2
2	243090	KIT, pump repair	1	72	116630	SCREW, square shank	6
13	243094	KIT, outlet valve (includes #17)	1	73	115480	KNOB, t-handle	2
17	103338	PACKING, o-ring, outlet valve	1	74	195366	AXLE	1
18	195947	FILTER, adapter	1	75	195367	SPACER	2
19	243070	PUMP, filter, InstaClean	1	76	115094	WHEEL, 10 in.	2
20	245070	KIT, inlet valve, intergral hose barb (includes #25)	1	77	112612	CAP	2
25	103413	PACKING, o-ring, inlet valve	1	78	105521	PLUG	2
26	116295	CLAMP, spring, 0.88 diameter	1	80	195105	HANGER, pail	1
36	246286	KIT, pressure switch, repair	1	83	115099	WASHER, inlet strainer	1
40	235014	KIT, spray/prime valve repair	1	84	15A473	TUBE, suction, barb (includes 83), Series A	1
43	224807	CAM, drain valve	1		15D883	TUBE, suction, Series B, C	1
44	187625	HANDLE, drain valve	1	85	243082	STRAINER	1
45	111600	DRIVE PIN, drain valve	1	86	15A475	TUBE, drain	1
46	114687	CLIP, retainer	1	87	115489	CLAMP, drain tube	2
47	245667	KIT, motor/drive housing, Series A, B	1	94	244035	DEFLECTOR, barbed	1
	287784	KIT, motor/drive housing, Series C	1	95	243024	HOSE, 1/4 in. x 50 ft	1
48	243231	KIT, fan and shield, Series A, B	1	96	243238	GUN, spray (model 232751 & 232752)	1
	287770	KIT, fan, Series C	1		243382	GUN, spray (model 232753)	1
51	245665	KIT, control board 230V	1	101	115719	PACKING, o-ring, filter, adapter	1
52	115477	SCREW, thread forming, #8	11	112	115651	NUT, hex, 5/16 in.	4
54	245062	KIT, gear, yoke, guide repair	1	123	196001	SPACER, pump	2
57	117219	SCREW, M3, washerhead	2	124	245666	ENCLOSURE (includes labels and screws), Series A, B	1
58	194507	DOWEL, pin 5/16	2		287785	ENCLOSURE (includes labels and screws), Series C	1
59	245823	RECEPTACLE, IEC 320	1	127	245053	PUMP, replacement (includes, #1, 2, 13, 17, 18, 19, 20, 40. Item #36 must be purchased separately)	1
60	115632	RETAINER, power cord	1	147	197211	CAP, pump outlet (included in Kit 245064)	1
61	15A467	BRACKET, filter	1	148	246187	ADAPTER, Geka to 3/4 in. GHT (not shown)	1
62	245064	COVER, front (includes ID labels)	1	149▲		LABEL, warning, multiple languages, see page 27 for specific part numbers	1
63	245725	ADAPTER, power cord, Schuko CEE7/7	1	150	245856	KIT, pressure gage (not shown) (included with models 232751 and 232752 only)	1
	245726	POWER CORD, Italy	1	151▲		LABEL, danger, multiple languages, see page 27 for specific part numbers	1
	245727	POWER CORD, Denmark	1	152▲		LABEL, danger, multiple languages, see page 27 for specific part numbers	1
	245728	POWER CORD, Australia	1				
	245729	POWER CORD, Switzerland	1				
65	115478	SCREW, torx/slit, 1/4 in.	8				
66	117223	SWITCH, rocker, dpst, Series A, B	1				
	119904	SWITCH, rocker, dspt, Series C	1				
67	195433	SUPPORT, right, Series A	1				
	15D923	SUPPORT, right, Series B, C	1				
68	195434	SUPPORT, left, Series A	1				
	15D924	SUPPORT, right, Series B, C	1				
69	195439	FRAME, cart	1				
70	195438	HANDLE, cart	1				

▲ Replacement Danger and Warning labels, tags, and cards are available at no cost.

XR9 Spray System

Model 232751, 232752, 232753 9 (Series A, B)

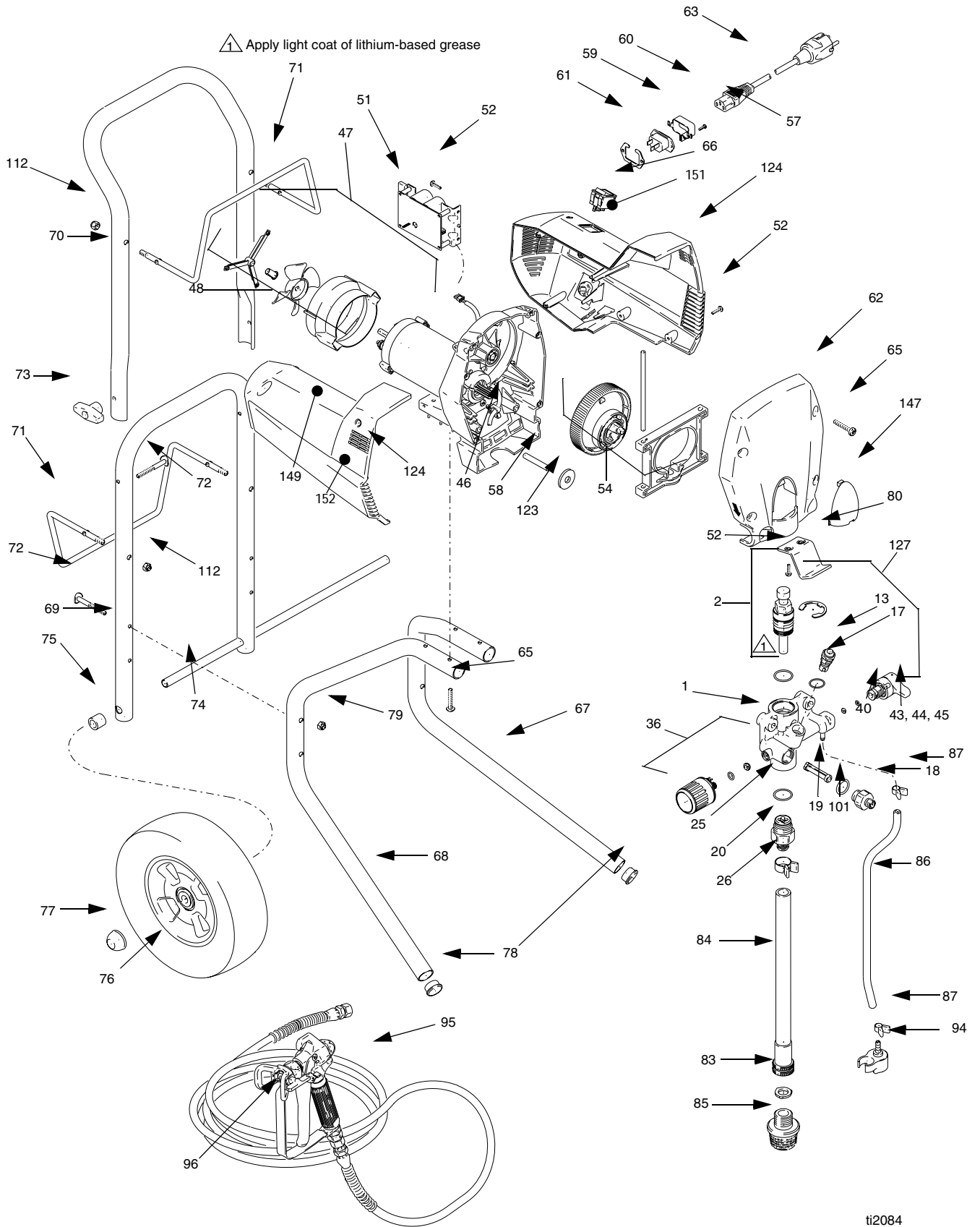

ti2084

XR9 Spray System Model 232751, 232752, 232753 (Series C)

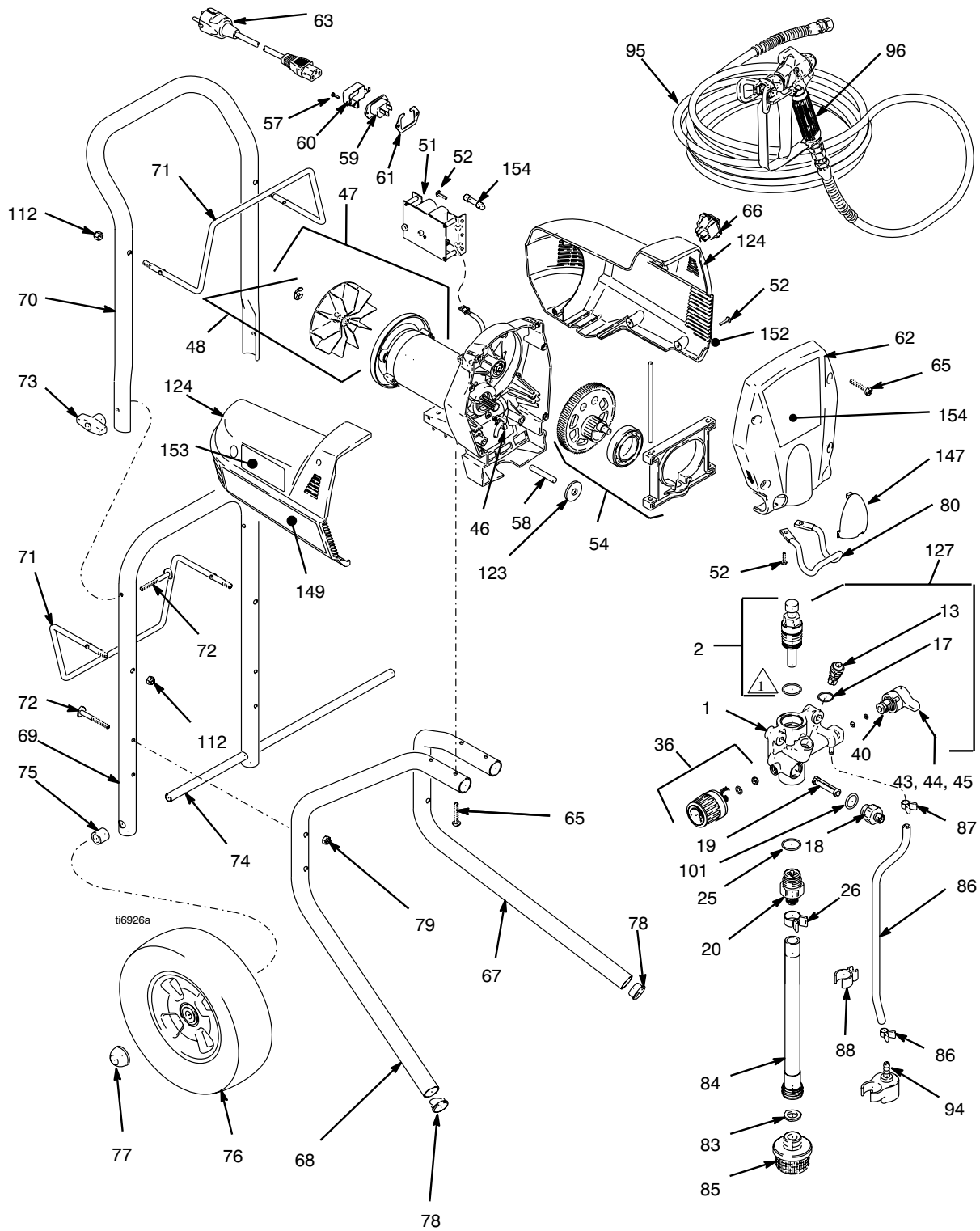

XR9 Spray System Labels

Ref No.	Part No.	Description	Qty	Ref No.	Part No.	Description	Qty
149	195792	LABEL, warning, English Japanese, Chinese, Korean	1		15G188	LABEL, danger, English Spanish, French, Series C	1
	195793	LABEL, warning, French, Spanish, German	1	152 ▲	15A674	LABEL, danger, Italian, Danish, German, Series A, B	1
	195794	LABEL, warning, Portuguese, Dutch, Italian, Greek	1		15G239	LABEL, danger, Italian, Danish, German, Series C	1
	195795	LABEL, warning, Swedish, Danish, Finnish, Norwegian	1		15A676	LABEL, danger, Finnish, Norwegian, Swedish, Series A, B	1
151	15A673	LABEL, danger, Italian, Danish, German, Series A, B	1		15G241	LABEL, danger, Finnish, Norwegian, Swedish, Series C	1
	15G238	LABEL, danger, Italian, Danish, German, Series C	1		15A678	LABEL, danger, Portuguese, Spanish, Greek, Series A, B	1
	15A675	LABEL, danger, Finnish, Norwegian, Swedish, Series A, B	1		15G243	LABEL, danger, Portuguese, Spanish, Greek, Series C	1
	15G240	LABEL, danger, Finnish, Norwegian, Swedish, Series C	1		15A706	LABEL, danger, Chinese, Korean, English, Series A, B	1
	15A677	LABEL, danger, Portuguese, Spanish, Greek, Series A, B	1		15G236	LABEL, danger, Chinese, Korean, English, Series C	1
	15G242	LABEL, danger, Portuguese, Spanish, Greek, Series C	1		195835	LABEL, danger, English, Spanish, French, Series A, B	1
	15A708	LABEL, danger, Chinese, Korean, English, Series A, B	1		15G187	LABEL, danger, English, Spanish, French, Series C	1
	15G237	LABEL, danger, Chinese, Korean, English, Series C	1				
	195834	LABEL, danger, English Spanish, French, Series A, B	1	▲		<i>Replacement Danger and Warning labels, tags, and cards are available at no cost.</i>	

Technical Data

	dx Roller/Spray System	XR9 Sprayer
Working pressure range	0 - 207 bar, 21 MPa (0 - 3,000 psi)	0 - 207 bar, 21 MPa (0 - 3,000 psi)
Electric motor	3.5 AMP (open frame, universal)	4.5 AMP (permanent magnet DC)
Operating horsepower	3/8	7/8
Maximum delivery (with tip)	0.91 lpm (0.24 gpm)	1.44 lpm (0.38 gpm)
Paint hose	7.6 m (25 ft) x 1/4 in.	15.2 m (50 ft) x 1/4 in.
Maximum tip hole size	0.38 mm (0.015 in.)	0.48 mm (0.019 in.)
Weight, sprayer only	6 kg (13 lb)	
Weight, sprayer, hose & gun	7.8 kg (17 lb)	
Dimensions:		
Length	41 cm (16 in.)	49.5 cm (19.5 in.)
Width	46 cm (18 in.)	48.3 cm (19 in.)
Height	53 cm (21 in.)	101.6 cm (40 in.)* <i>*Height with folded handle is 66 cm (26 in.)</i>
Power cord	3 wire, 1.0 mm ² x 2.0 m (78 in.)	3 wire, 1.0 mm ² x 2.0 m (78 in.)
Fluid inlet fitting		
Fluid outlet fitting	1/4 npsm external thread	1/4 npsm external thread
Inlet screen on suction tube	450 micron (35 mesh)	450 micron (35 mesh)
Wetted parts, pump & hose	stainless steel, brass, ultra-high molecular weight polyethylene (UHMWPE), carbide, nylon, aluminum, PVC, polypropylene, fluoroelastomer	stainless steel, brass, leather, ultra-high molecular weight polyethylene (UHMWPE), carbide, nylon, aluminum, PVC, polypropylene, fluoroelastomer
Wetted parts, gun	aluminum, brass, carbide, nylon, plated steel, stainless steel, UHMWPE, zinc	aluminum, brass, carbide, nylon, plated steel, stainless steel, UHMWPE, zinc
Generator requirement	1500 Watt minimum	1500 Watt minimum
Electrical power requirement	220-240 V AC, 50/60 Hz, 1 phase, 10 A	220-240 V AC, 50/60 Hz, 1 phase, 10 A
Storage temperature range *❖	-35° to 71°C (-30° to 160°F)	-35° to 71°C (-30° to 160°F)
Operating temperature range ✓	4° to 46°C (40° to 115°F)	4° to 46°C (40° to 115°F)

* When pump is stored with non-freezing fluid. Pump damage will occur if water or latex paint freezes in pump.

❖ Damage to plastic parts may result if impact occurs in low temperature conditions.

✓ Changes in paint viscosity at very low or very high temperatures can affect sprayer performance.

Graco Warranty

Graco warrants all equipment referenced in this document which is manufactured by Graco and bearing its name to be free from defects in material and workmanship on the date of sale to the original purchaser for use. With the exception of any special, extended, or limited warranty published by Graco, Graco will, for a period of twelve months from the date of sale, repair or replace any part of the equipment determined by Graco to be defective. This warranty applies only when the equipment is installed, operated and maintained in accordance with Graco's written recommendations.

This warranty does not cover, and Graco shall not be liable for general wear and tear, or any malfunction, damage or wear caused by faulty installation, misapplication, abrasion, corrosion, inadequate or improper maintenance, negligence, accident, tampering, or substitution of non-Graco component parts. Nor shall Graco be liable for malfunction, damage or wear caused by the incompatibility of Graco equipment with structures, accessories, equipment or materials not supplied by Graco, or the improper design, manufacture, installation, operation or maintenance of structures, accessories, equipment or materials not supplied by Graco.

This warranty is conditioned upon the prepaid return of the equipment claimed to be defective to an authorized Graco distributor for verification of the claimed defect. If the claimed defect is verified, Graco will repair or replace free of charge any defective parts. The equipment will be returned to the original purchaser transportation prepaid. If inspection of the equipment does not disclose any defect in material or workmanship, repairs will be made at a reasonable charge, which charges may include the costs of parts, labor, and transportation.

THIS WARRANTY IS EXCLUSIVE, AND IS IN LIEU OF ANY OTHER WARRANTIES, EXPRESS OR IMPLIED, INCLUDING BUT NOT LIMITED TO WARRANTY OF MERCHANTABILITY OR WARRANTY OF FITNESS FOR A PARTICULAR PURPOSE.

Graco's sole obligation and buyer's sole remedy for any breach of warranty shall be as set forth above. The buyer agrees that no other remedy (including, but not limited to, incidental or consequential damages for lost profits, lost sales, injury to person or property, or any other incidental or consequential loss) shall be available. Any action for breach of warranty must be brought within two (2) years of the date of sale.

GRACO MAKES NO WARRANTY, AND DISCLAIMS ALL IMPLIED WARRANTIES OF MERCHANTABILITY AND FITNESS FOR A PARTICULAR PURPOSE, IN CONNECTION WITH ACCESSORIES, EQUIPMENT, MATERIALS OR COMPONENTS SOLD BUT NOT MANUFACTURED BY GRACO. These items sold, but not manufactured by Graco (such as electric motors, switches, hose, etc.), are subject to the warranty, if any, of their manufacturer. Graco will provide purchaser with reasonable assistance in making any claim for breach of these warranties.

In no event will Graco be liable for indirect, incidental, special or consequential damages resulting from Graco supplying equipment hereunder, or the furnishing, performance, or use of any products or other goods sold hereto, whether due to a breach of contract, breach of warranty, the negligence of Graco, or otherwise.

FOR GRACO CANADA CUSTOMERS

The Parties acknowledge that they have required that the present document, as well as all documents, notices and legal proceedings entered into, given or instituted pursuant hereto or relating directly or indirectly hereto, be drawn up in English. Les parties reconnaissent avoir convenu que la rédaction du présente document sera en Anglais, ainsi que tous documents, avis et procédures judiciaires exécutés, donnés ou intentés, à la suite de ou en rapport, directement ou indirectement, avec les procédures concernées.

ADDITIONAL WARRANTY COVERAGE

Graco does provide extended warranty and wear warranty for products described in the "Graco Contractor Equipment Warranty Program".

***TO PLACE AN ORDER or to identify the nearest
Graco/Magnum distributor, contact us at
1-888-541-9788.***

*All written and visual data contained in this document reflects the latest product information available at the time of publication.
Graco reserves the right to make changes at any time without notice.*

MM 309477G

Graco Headquarters: Minneapolis

International Offices: Belgium, China, Japan, Korea

GRACO INC. P.O. BOX 1441 MINNEAPOLIS, MN 55440-1441

www.graco.com

Rev 3/2007