

Orion™ Piston Pumps and Spray Packages



Important Safety Instructions

Read all warnings and instructions in this manual.
Save these instructions.

309512 rev. C

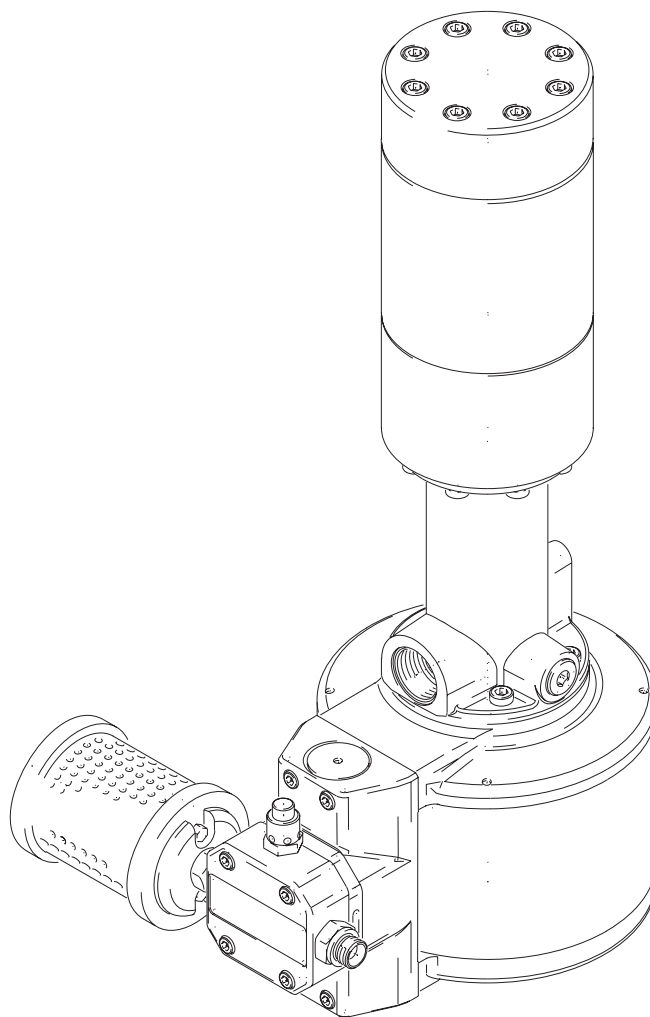

PROVEN QUALITY. LEADING TECHNOLOGY.

Contents

Model Information	3	Repair	15
Bare Pumps	3	Tools Required	15
Spray Packages	3	Disconnect the Motor from the Displacement Pump	15
Related Manuals	3	Reconnect the Motor to the Displacement Pump	15
Warnings	4	Air Valve Repair	16
General Information	6	Air Motor Piston and Cylinder Repair	17
Grounding	6	Bellows Repair	19
Mounting Accessories	7	Displacement Pump Repair	21
Install the Muffler	7	Parts	23
Air Inlet Fitting	7	Complete Pump	23
Air and Fluid Hoses	7	Air Motor	24
Air Line Accessories	7	Pump Lowers	26
Fluid Inlet Adapter	7	028.050 and 015.085	26
Fluid Line Accessories	7	Wall Mount Packages	28
Operation	9	234087 (015.085) and 234089 (028.050)	28
Pressure Relief Procedure	9	Cart Mount Packages	29
Flush the Pump Before First Use	9	Air Inlet Details	30
Start and Adjust the Pump	10	Accessories	30
Shutdown and Care of the Pump	10	Gun/Siphon Hose Kits	32
Flush the Equipment	11	Alpha+ (246300)	32
Maintenance	12	Silver+ (246301)	33
Preventive Maintenance Schedule	12	Technical Data	34
Storage	12	Performance Charts	35
Tighten Threaded Connections	12	Dimensions	36
Cleaning	12	Graco Warranty	38
Troubleshooting	13	Graco Phone Numbers	38

Manual Conventions

Warning

WARNING

A warning alerts you to the possibility of serious injury or death if you do not follow the instructions.

Symbols, such as fire and explosion (shown above), alert you to a specific hazard and direct you to read the indicated hazard warnings (pages 4-5) for detailed information.

Caution

CAUTION

A caution alerts you to the possibility of damage to or destruction of equipment if you do not follow the instructions.

Note

A note calls attention to additional helpful information.

Model Information

Bare Pumps

Pump Part No.	Thread Type	Pump Ratio	Pump Model (see key below)	Air Motor diameter in. (mm)	Displacement Pump Volume per Stroke	Maximum Air Input Pressure psi (bar, MPa)	Maximum Fluid Working Pressure psi (bar, MPa)
245934	BSPP	28:1	028.050.BSPP	6.30 (D160)	1.7 oz. (50 cc)	116 (8, 0.8)	3248 (224, 22.4)
245935	BSPP	15:1	015.085.BSPP	6.30 (D160)	2.8 oz. (85 cc)	116 (8, 0.8)	1740 (120, 12.0)
234084	npt	15:1	015.085.npt	6.30 (D160)	2.8 oz. (85 cc)	116 (8, 0.8)	1740 (120, 12.0)
234085	npt	28:1	028.050.npt	6.30 (D160)	1.7 oz. (50 cc)	116 (8, 0.8)	3248 (224, 22.4)

Key to Pump Model Designation

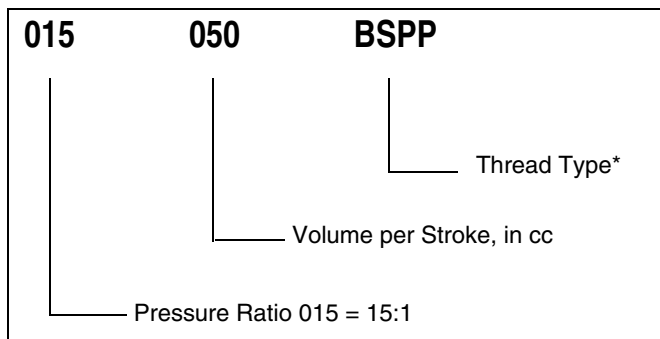

* BSPP stands for British Standard Pipe Parallel Thread
 npt stands for National Pipe Taper Thread

Spray Packages

When ordering a package, order Gun/Siphon Hose kit separately. See pages 32 and 33 for part numbers.

Sprayer Part No.	Series	Ratio	Sprayer Includes:				Mounting Configuration:		Maximum Air Input Pressure MPa, (bar, psi)	Maximum Fluid Working Pressure MPa, (bar, psi)
			Pump Model	Thread Type	Air Controls	Fluid Filter	Wall Bracket	Cart		
234087	A	15:1	015.085	npt	✓	✓	✓		0.8, (8, 116)	12.0, (120, 1740)
234089	A	28:1	028.050	npt	✓	✓	✓		0.8, (8, 116)	22.4, (224, 3248)
234091	A	15:1	015.085	npt	✓	✓		✓	0.8, (8, 116)	12.0, (120, 1740)
234093	A	28:1	028.050	npt	✓	✓		✓	0.8, (8, 116)	22.4, (224, 3248)

Related Manuals

This manual is available in the following languages:

Manual	Language	Manual	Language
309512	English	309671	German
309669	Spanish	309672	Swedish
309670	French	309673	Italian

Warnings

WARNING



EQUIPMENT MISUSE HAZARD

Equipment misuse can cause the equipment to rupture or malfunction and result in serious injury.



- This equipment is for professional use only.
- Read all instruction manuals, tags, and labels before operating the equipment.
- Use the equipment only for its intended purpose. If you are not sure, call your Graco distributor.
- Do not alter or modify this equipment.
- Check equipment daily. Repair or replace worn or damaged parts immediately.
- Do not exceed the maximum working pressure of the lowest rated system component. Refer to the Technical Data on page 34 for the maximum working pressure of this equipment.
- Use fluids and solvents which are compatible with the equipment wetted parts. Refer to the Technical Data section of all equipment manuals. Read the fluid and solvent manufacturer's warnings.
- Do not use hoses to pull equipment.
- Route hoses away from traffic areas, sharp edges, moving parts, and hot surfaces. Do not expose Graco hoses to temperatures above 82°C (180°F) or below -40°C (-40°F).
- Wear hearing protection when operating this equipment.
- Do not lift pressurized equipment.
- Comply with all applicable local, state, and national fire, electrical, and safety regulations.



SKIN INJECTION HAZARD

Spray from the gun, leaks or ruptured components can inject fluid into your body and cause extremely serious injury, including the need for amputation. Fluid splashed in the eyes or on the skin can also cause serious injury.

- Fluid injected into the skin might look like just a cut, but it is a serious injury. **Get immediate surgical treatment.**
- Do not point the gun at anyone or at any part of the body.
- Do not put your hand or fingers over the spray tip.
- Do not stop or deflect leaks with your hand, body, glove or rag.
- Do not “blow back” fluid; this is not an air spray system.
- Always have the tip guard and the trigger guard on the gun when spraying.
- Check the gun diffuser operation weekly. Refer to the gun manual.
- Be sure the gun trigger safety operates before spraying.
- Lock the gun trigger safety when you stop spraying.
- Follow the Pressure Relief Procedure on page 9 if the spray tip clogs and before cleaning, checking or servicing the equipment.
- Tighten all fluid connections before operating the equipment.
- Check the hoses, tubes, and couplings daily. Replace worn or damaged parts immediately.
- Do not repair high pressure couplings; you must replace the entire hose.

WARNING	
	<p>MOVING PARTS HAZARD</p> <p>Moving parts, such as the air motor piston, can pinch or amputate your fingers.</p> <ul style="list-style-type: none"> • Before servicing the equipment, follow the Pressure Relief Procedure on page 9 to prevent the equipment from starting unexpectedly.
	<p>FIRE AND EXPLOSION HAZARD</p> <p>Improper grounding, poor ventilation, open flames or sparks can cause a hazardous condition and result in a fire or explosion and serious injury.</p> <ul style="list-style-type: none"> • Ground the equipment and the object being sprayed. Refer to Grounding on page 6. • If there is any static sparking or you feel an electric shock while using this equipment, stop spraying immediately. Do not use the equipment until you identify and correct the problem. • Provide fresh air ventilation to avoid the buildup of flammable fumes from solvents or the fluid being sprayed. • Keep the spray area free of debris, including solvent, rags, and gasoline. • Electrically disconnect all equipment in the spray area. • Extinguish all open flames or pilot lights in the spray area. • Do not smoke in the spray area. • Do not turn on or off any light switch in the spray area while operating or if fumes are present. • Do not operate a gasoline engine in the spray area.
	<p>TOXIC FLUID HAZARD</p> <p>Hazardous fluid or toxic fumes can cause serious injury or death if splashed in the eyes or on the skin, inhaled, or swallowed.</p> <ul style="list-style-type: none"> • Know the specific hazards of the fluid you are using. • Store hazardous fluid in an approved container. Dispose of hazardous fluid according to all local, state and national guidelines. • Always wear protective eyewear, gloves, clothing and respirator as recommended by the fluid and solvent manufacturer.

General Information

- Reference numbers and letters in parentheses in the text refer to the callouts in the figures and the parts drawing.
- Always use Genuine Graco Parts and Accessories, available from your Graco distributor. If you supply your own accessories, be sure they are adequately sized and pressure-rated for your system.
- These pumps are mounted with the air motor below the fluid section (see FIG. 2) for two reasons. First, this orientation positions the fluid section so that the inlet is below the outlet to ensure that all air is evacuated when the pump is filled with fluid and to optimize suction capability. Second, this orientation eliminates the need for springs on the ball checks, improving flushability.
- FIG. 2 is a guide for selecting and installing system components and accessories. It is not an actual system design. Contact your Graco distributor for assistance in designing a system to suit your particular needs.

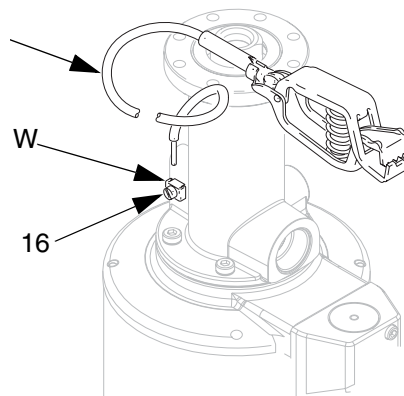



FIG. 1 Grounding Wire

2. *Air and fluid hoses:* use only electrically conductive hoses.
3. *Air compressor:* follow manufacturer's recommendations.
4. *Spray gun:* ground through connection to a properly grounded fluid hose and pump.
5. *Fluid supply container:* follow your local code.
6. *Object being sprayed:* follow your local code.
7. *Solvent pails used when flushing:* follow your local code. Use only metal pails, which are conductive, placed on a grounded surface. Do not place the pail on a nonconductive surface, such as paper or cardboard, which interrupts the grounding continuity.



Grounding



WARNING



Before operating the pump, ground the system as explained below. Read the warnings on page 5.

1. *Pump:* use a ground wire and clamp. See FIG. 1. Insert one end of a 1.5 mm³ (12 ga) minimum ground wire (Y) into the pump's grounding clamp (16) and tighten the screw (W) securely. Connect the other end of the wire to a true earth ground. Order Part No. 238909 Ground Wire.

8. *To maintain grounding continuity when flushing or relieving pressure,* hold a metal part of the spray gun firmly to the side of a grounded *metal* pail, then trigger the gun.

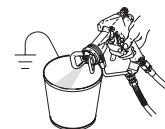

Mounting Accessories

Mount the pump (E) to suit the type of installation planned. FIG. 2 illustrates a wall mount system. Pump dimensions are shown on page 36.

1. Be sure the mounting surface can support the weight of the pump, bracket, hoses and accessories, as well as the stress caused during operation.
2. Position the wall bracket about 1.2-1.5 m (4-5 ft) above the floor. For ease of operation and service, make sure the pump air inlet, fluid inlet, and fluid outlet are easily accessible.
3. Drill mounting holes in the wall. Attach the bracket to the wall. Use screws that are long enough to keep the pump from vibrating during operation. Be sure the bracket is level.

Install the Muffler

The muffler (C) is shipped loose. Screw the muffler into the muffler port before installing the pump.

Air Inlet Fitting

A 1/4 npt air inlet fitting 245718 (113) is supplied on bare pumps 234084 and 234085. It is held in place with a setscrew (47). Loosen the setscrew before removing the fitting. Tighten the setscrew to hold the fitting in place.

A 3/8 bspp(m) air inlet fitting (245682) is supplied on Models 245934 and 245935.

Air and Fluid Hoses

Be sure all air hoses (A, P) and fluid hoses (R, U) are properly sized and pressure-rated for your system. Use only electrically conductive fluid hoses. Fluid hoses should have spring guards on both ends. Use a swivel (S) between the fluid hose (R or U) and the gun (T) to allow easier gun movement.

CAUTION
The pump must be suction-fed in order to operate properly. Pressure feeding the pump will cause bellows seal failure.

Air Line Accessories

Install the following accessories in the order shown in FIG. 2, using adapters as necessary:

- A bleed-type master air valve (B) is required in your system to relieve air trapped between it and the air motor when the valve is closed. Be sure the bleed valve is easily accessible from the pump.
- A pump air regulator (D) controls pump speed and outlet pressure by adjusting the air pressure to the pump. Locate the regulator close to the pump.
- A gun air regulator (N) controls air pressure to the air-assisted spray gun.
- An air line filter (M) removes harmful dirt and moisture from the compressed air supply.
- A second bleed-type air valve (L) isolates the air line accessories for servicing. Locate upstream from all other air line accessories.

Fluid Inlet Adapter

A 3/4 npt fluid inlet adapter (115) is supplied on Models 234084 and 234085 only. Models 245934 and 245935 have a 1" bspp female port.

Fluid Line Accessories

Install the following accessories in the positions shown in FIG. 2, using adapters as necessary:

- A fluid filter (F) with a 60 mesh (250 micron) stainless steel element, to filter particles from the fluid as it leaves the pump. Install a fluid drain valve (G), which is required in your system to relieve fluid pressure in the hose and gun.
- A fluid shutoff valve (H) shuts off fluid flow.
- A fluid pressure regulator (J) allows more precise adjustment of the fluid pressure.
- A gun or valve (T) dispenses the fluid. The gun shown in FIG. 2 is an air-assisted spray gun for light to medium viscosity fluids.
- A fluid line swivel (S) allows easier gun movement.
- A suction kit (K) allows the pump to draw fluid from a fluid container.
- A 3/8 BSPP female port (Z) allows for fluid recirculation.

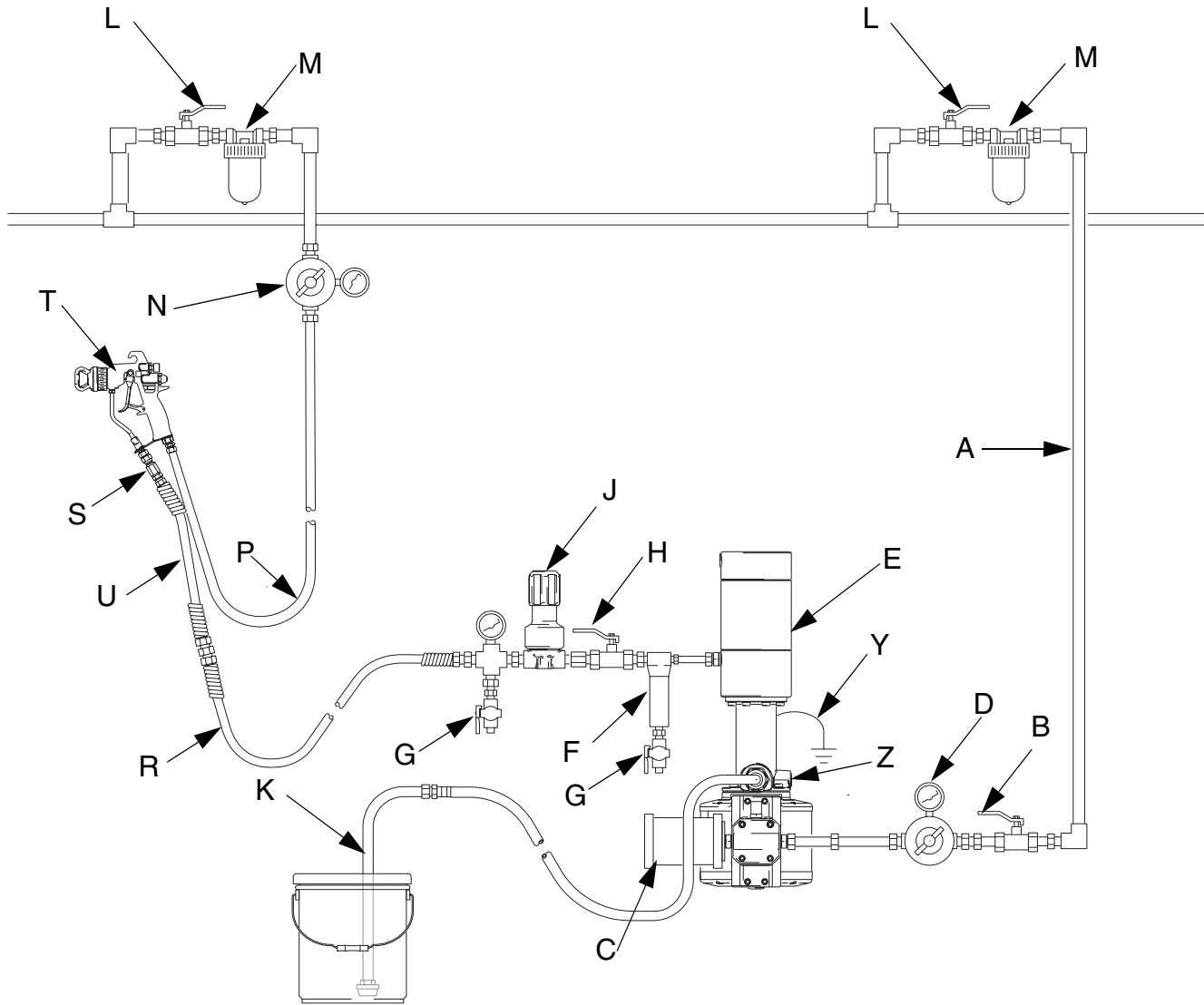

T12364A

FIG. 2 Typical Installation (Wall Mount Shown)



Key:

- | | |
|-------------------------------|------------------------------|
| A Pump Air Supply Line | N Gun Air Pressure Regulator |
| B Bleed-Type Master Air Valve | P Gun Air Supply Line |
| C Muffler | R Gun Fluid Supply Line |
| D Pump Air Pressure Regulator | S Gun Swivel |
| E Pump | T Air-Assisted Spray Gun |
| F Fluid Filter | U Fluid Whip Hose |
| G Fluid Drain Valve | Y Pump Ground Wire |
| H Fluid Shutoff Valve | Z Recirculation Port |
| J Fluid Pressure Regulator | |
| K Fluid Suction Tube | |
| L Air Shutoff Valve | |
| M Air Line Filter | |

Operation

Pressure Relief Procedure

 **WARNING**

Read the warnings on page 5, and follow the Pressure Relief Procedure below whenever you:

- are instructed to relieve pressure
- stop spraying
- check or service any of the equipment
- install or clean the spray tip.

1. Lock the gun trigger.

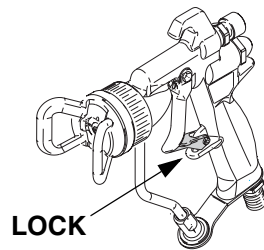

2. Turn off the air bleed valves to the fluid source and to the gun.

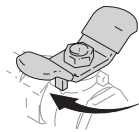

3. Unlock the gun trigger.

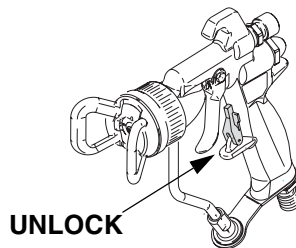

4. Trigger the gun into a grounded metal waste container to relieve the fluid pressure.

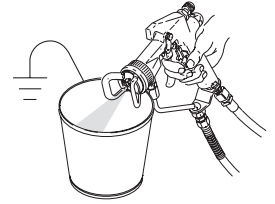

5. Lock the trigger.

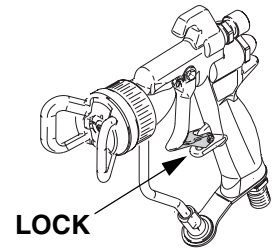

6. Open the drain valve on the fluid filter and all other fluid drain valves in the system, having a waste container ready to catch the drainage. Leave the drain valve(s) open until you are ready to spray again.

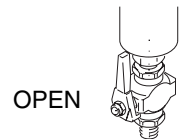

7. If the nozzle or hose is completely clogged or pressure is not fully relieved, slowly loosen the hose end coupling. Now clear the nozzle or hose.

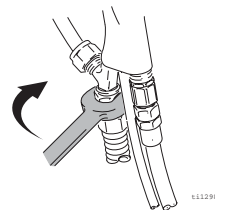

Flush the Pump Before First Use

The pump is tested with lightweight oil, which is left in to protect the pump parts. If the fluid you are using may be contaminated by the oil, flush it out with a compatible solvent before using the pump. See **Flush the Equipment** on page 11.

Start and Adjust the Pump

1. Connect the suction kit (K) to the pump's fluid inlet, and place the tube into the fluid supply.
2. Close the air regulator (D).

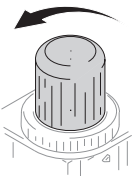

3. Open the pump's bleed-type master air valve (B).

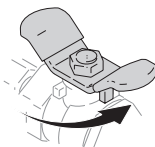

4. Hold a metal part of the gun (T) firmly to the side of a grounded metal pail and hold the trigger open.

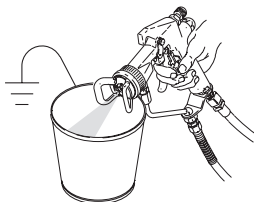

5. Slowly open the air regulator (D) until the pump starts.

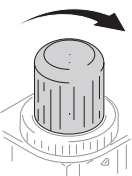

6. Cycle the pump slowly until all air is pushed out and the pump and hoses are fully primed.
7. Release the gun trigger and lock the trigger safety latch. The pump should stall against pressure.

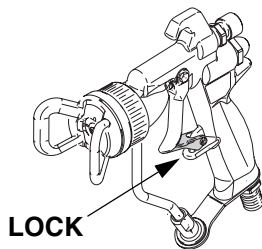

8. If the pump fails to prime properly, open the drain valve (G). Use the drain valve as a priming valve until fluid flows from the valve. Close the drain valve when all air is eliminated.

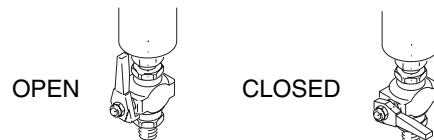

9. With the pump and lines primed, and with adequate air pressure and volume supplied, the pump will start and stop as you open and close the gun. In a circulating system, the pump will speed up or slow down on demand, until the air supply is shut off.
10. Use the air regulator to control the pump speed and the fluid pressure. Always use the lowest air pressure necessary to get the desired results. Higher pressures cause premature tip and pump wear.

CAUTION

Never allow the pump to run dry of the fluid being pumped. A dry pump will quickly accelerate to a high speed, possibly damaging itself. If your pump accelerates quickly, or is running too fast, stop it immediately and check the fluid supply. If the supply container is empty and air has been pumped into the lines, refill the container and prime the pump and the lines with fluid, or flush and leave it filled with a compatible solvent. Be sure to eliminate all air from the fluid system.

Shutdown and Care of the Pump

For a brief shutdown, relieve the pressure (page 9). For a longer shutdown, or overnight, always flush the pump, (page 11) and relieve the pressure, (page 9).

Flush the Equipment

Flush before changing colors, at the end of the day, before storing, and before repairing the equipment.

 **WARNING**



Before flushing, be sure the entire system and all grounding pails are properly grounded. See page 6.

Flush with a fluid that is compatible with the fluid you are pumping and with the wetted parts of your system. Check with your fluid manufacturer or supplier for recommended flushing fluids and flushing frequency.

1. Relieve the pressure, page 9.

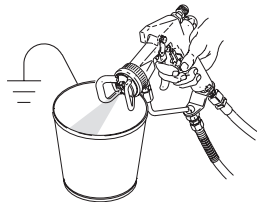

2. Remove the spray tip from the gun. See the gun manual.
3. Change the fluid source to solvent.



4. Hold a metal part of the gun firmly to the side of a grounded metal pail.
5. Start the pump. Always use the lowest possible fluid pressure when flushing.

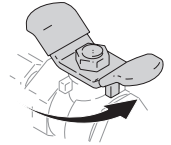

6. Trigger the gun. Flush until clean solvent flows from the gun.

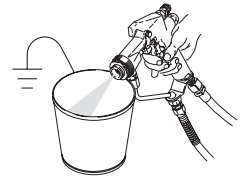

7. Relieve the pressure, page 9.

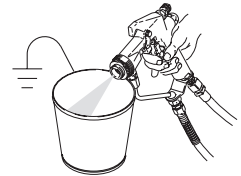

Maintenance

Preventive Maintenance Schedule

Establish a preventive maintenance schedule, based on the pump's service history.

Storage

Before storing the pump, always flush it, page 11.
Relieve the pressure, page 9.

Tighten Threaded Connections

Before each use, check all hoses for wear or damage. Replace as necessary. Check that all threaded connections are tight and leak-free.

Cleaning

Clean the outside of the equipment daily, using a soft cloth and compatible solvent.

Clean the suction tube (K) and inlet strainer daily, using a compatible solvent.

Clean the air filter (M) in your main air line at least once a week.

Troubleshooting

1. Relieve the pressure (page 9) before checking or servicing the equipment.
2. Check all possible problems and causes before disassembling the pump.

Problem	Cause	Solution
Pump operates erratically.	Clogged suction tube or filter.	Clear part(s).
	Exhausted fluid supply or damaged suction section causing air to be entrained into the fluid section.	Refill fluid supply or repair suction device.
Pump fails to operate or operates erratically or with low output.	Restricted line or inadequate air supply; closed or clogged valves.	Clear line or increase air supply. Check that valves are open.
	Obstructed fluid hose or gun; fluid hose ID is too small.	Open, clear*; use hose with larger ID.
Output fluid pressure fluctuations.	Damaged or worn piston.	Replace damaged part(s)
	Damaged or worn U-cup seals.	
	Air in fluid section.	Eliminate air
Pump freezes up.	Compressed air too damp.	Change operating conditions.
	Stroke frequency too high.	
	Ambient temperature too low.	
Pump stalls, fails to operate properly (e.g., no resistance), or provides low output in the downward stroke.	Pressure valve not shutting off properly, due either to an obstruction or to wear of the ball and/or seat.	Clear valve. Replace damaged part(s).
Pump stalls, fails to operate properly (e.g., no resistance), or provides low output in the upward stroke.	Suction valve not shutting off properly, due either to an obstruction or to wear of the ball and/or seat.	Clear valve. Replace damaged part(s).
Material visible in weep hole at back of air motor.	Ruptured bellows	Replace damaged part(s).
	Damaged o-rings.	
Air continuously escapes from the exhaust.	Damaged air valve seat or air valve cup.	Replace damaged part(s). Filter compressed air supply.

* To determine if the fluid hose or gun is obstructed, relieve the pressure. Disconnect the fluid hose and place a container at the pump fluid outlet to catch any fluid. Turn on the air just enough to start the pump. If the pump starts when the air is turned on, the obstruction is in the hose or gun.

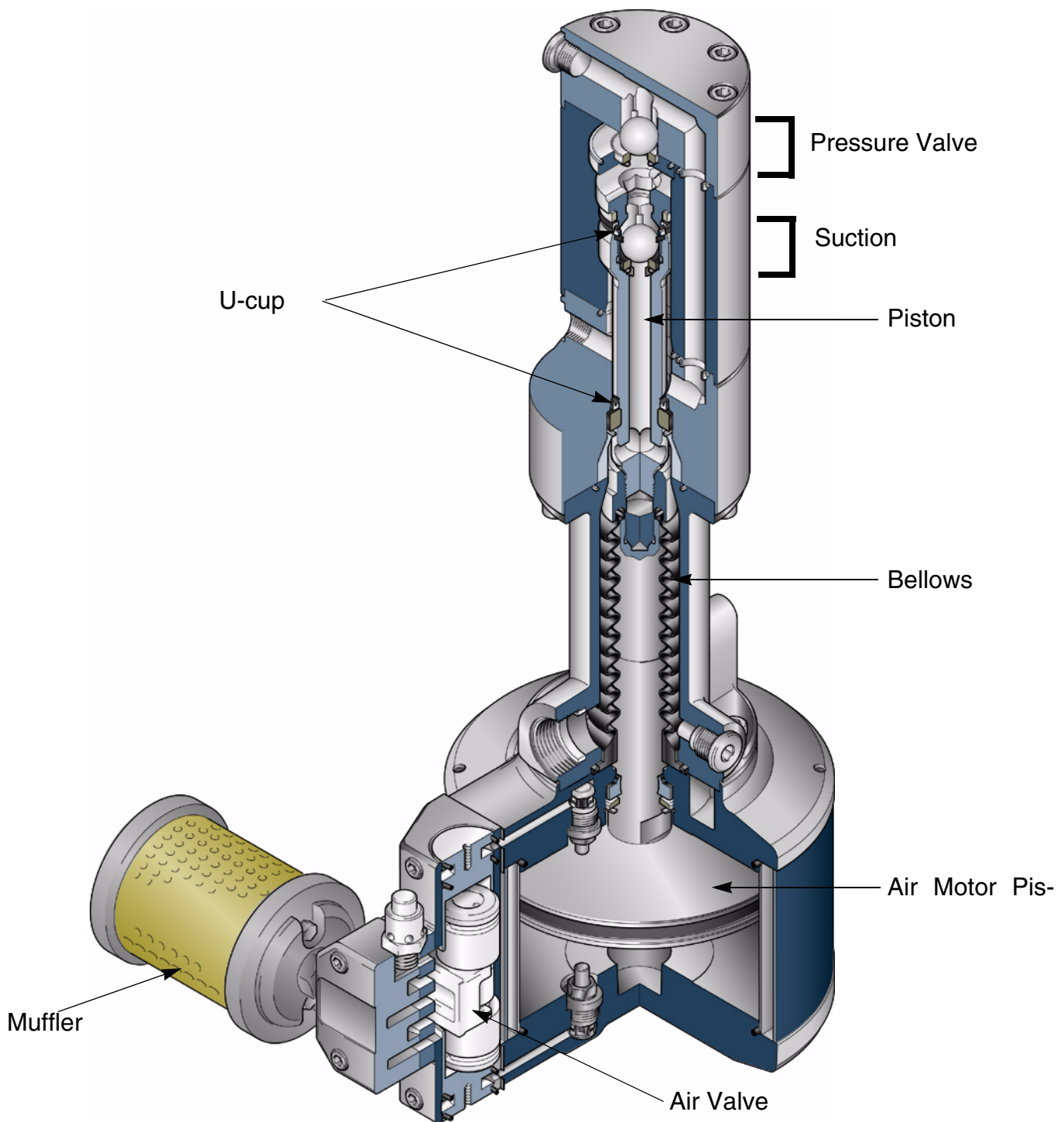

FIG. 3 Cutaway View

Repair

Tools Required

- Hex wrenches - sizes 3, 5, 6, 8, 14, 17mm
- Open-ended spanner wrenches - sizes 22, 30mm
- Pliers
- Open-ended socket wrench - size 12mm

Disconnect the Motor from the Displacement Pump

1. Flush the pump, if possible (page 11). Relieve the pressure (page 9).
2. Disconnect the air and fluid hoses and the ground wire.
3. Remove the pump from its mounting and take it to the work bench.
4. Remove the screws (103). Be careful not to lose the associated lock washers (104).
5. Pull the displacement pump away from the air motor enough to insert a tool (screwdriver, hex wrench, etc.) into the cross hole of the piston (A).

CAUTION

- Never twist the bellows. The threaded connector should never be loosened until the housing has been removed. Conversely, the housing should never be installed until the bellows is securely attached to the piston rod with the threaded connector.

6. Holding the mating threaded insert (3) in the air motor across its 30 mm flats, unscrew the piston.

 When the threaded insert (3) is accessible, the air motor piston is in its fully extended position and should remain in this position throughout any further disassembly of the air motor.

Reconnect the Motor to the Displacement Pump

1. Reconnect the threaded piston to the threaded insert in the air motor. Torque to 61-68 N•m (45-50 ft-lb). Push the fluid section down onto the air motor.
2. Install the lock washers (104) and screws (103). Torque to 6.8-7.3 N•m (60-65 in-lb).
3. Reinstall the pump on its mounting.
4. Reconnect the ground wire and the air and fluid hoses. Return the pump to service.

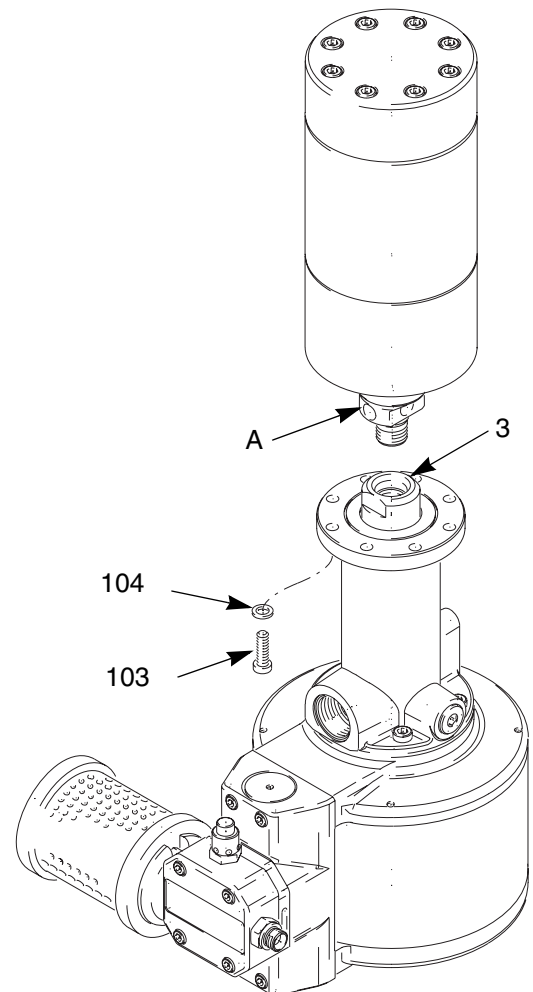



FIG. 4 Pump Connection

Air Valve Repair

 To repair the air valve, order Repair Kit 233836. Parts included in the kit are marked, for example (34‡).

Disassembly

1. Remove the screws (35) and take the air valve housing (29) off the air motor. Remove the gaskets (34). See FIG. 5.
2. Remove the screws (46).
3. Remove the air valve cover (45), seat (44), and cup (43). See FIG. 6.
4. Remove the setscrews (69). Disassemble the piston assembly. See FIG. 7. Use screw (46) to remove the first bushing (50). Both the screw and the internal threads on the bushing are M6x1.

 Torque to 10-11 N•m (90-100 in-lb)

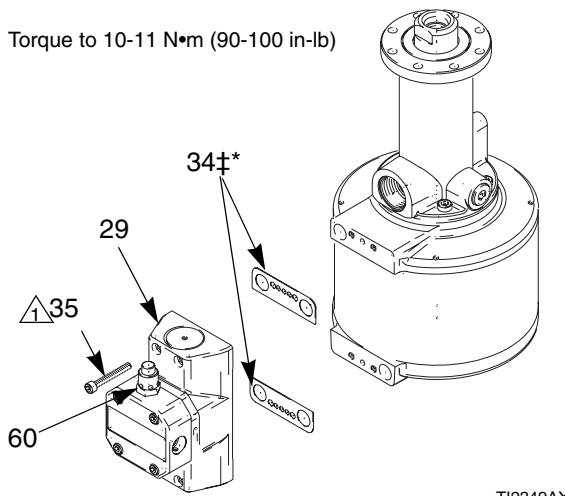



FIG. 5 Air Valve

 Torque to 10-11 N•m (90-100 in-lb)

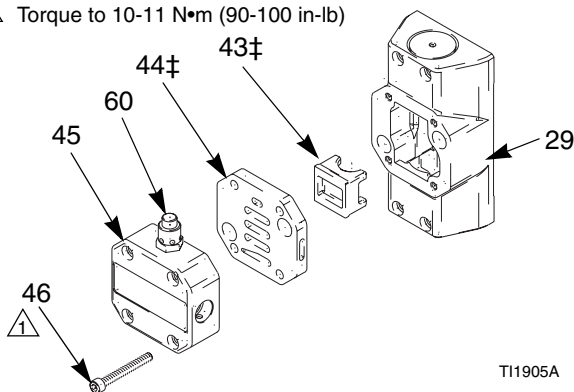

FIG. 6 Air Valve Cover, Seat, and Cup

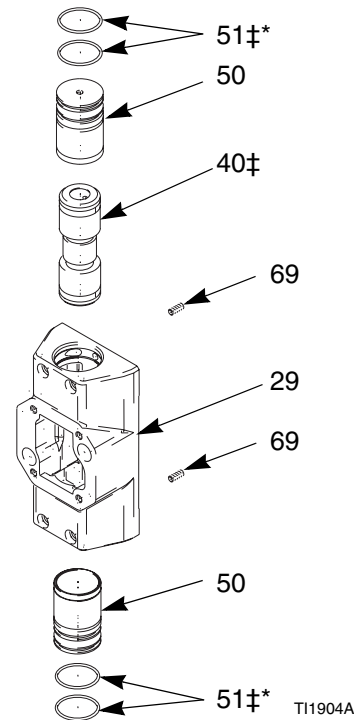

FIG. 7 Air Valve Piston Assembly

Reassembly

1. Install the o-rings (51‡) on the bushings (50) and install one bushing in the housing (29). Install the piston (40‡) and the other bushing. Install the setscrews (69) to secure.
2. Place the cup (43‡) into the housing (29) so it rides on the air valve piston. See FIG. 6.
3. Install the seat (44‡) and cover (45) as shown. Make sure the holes in the seat align with the holes in the housing (29), and note the orientation of the relief valve (60) in the cover. Torque the screws (46) to 10-11 N•m (90-100 in-lb).
4. Grease the inside surfaces of the housing (29) facing the gaskets (34‡), then position the gaskets as shown in FIG. 5. Install the air valve with the relief valve (60) facing up. Torque the screws (35) to 10-11 N•m (90-100 in-lb).

Air Motor Piston and Cylinder Repair



- Air Motor Seal Repair Kits are available. Order repair kit 234041. Parts included in the kit are marked, for example (1*).

Disassembly

To repair the piston rod, order Repair Kit 234042. Parts included in the kit are marked, for example (4†).

1. Disconnect the displacement pump from the air motor (page 15).
2. Remove the air valve (29) and gaskets (34*) (page 16).
3. Remove the screws (12). Remove the cylinder cover (32) from the air motor. Remove the pilot valve (14) and the o-ring (23*) from the cover. See FIG. 8.
4. Remove the round cover (20) and cylinder (21). Inspect the inside surface of the cylinder for scratches or other damage. See FIG. 8.
5. Remove screws (10) and lock washers (11). Verify the piston (19) is in its fully extended position (threaded insert (3) protrudes from the top of the housing).
6. Remove the threaded insert (3) from the top of the housing and pull the piston (19) and rod (4†) straight out of the bottom of the housing. Do not tilt the piston to prevent damage to the rod. Remove the o-ring (27*). See FIG. 8.
7. Inspect the piston rod (4†) for wear or damage. If the rod is damaged, disassemble the piston assembly. Keep the piston (19) for reuse. Discard the piston rod (4†) and the cap screw (22†). These parts must be replaced together.
8. Remove the o-ring (23*) and pilot valve (14) from the air motor base (13). Use a clip removal tool to take out the c-clip (25*), then remove the washer (18*), ring and seal (17A* and 17B*). Note the orientation of these parts. See FIG. 8.



- For replacement of o-rings (2* and 24*), refer to **Bellows Repair** on page 19.
- For replacement of o-rings (51*), refer to **Air Valve Repair** on page 16.
- For replacement of seal (36*) and pin (38*), refer to the exploded view of the Air Motor, page 25.

Reassembly

1. Lubricate the o-ring and the center bore in the base (13). Install the seal (17B*) with the groove facing away from the bellows, then install the ring (17A*) in the groove with notches facing up. Install the washer (18*) with the flat side facing up, then the retaining ring (25*). See FIG. 8.
2. Install the o-ring (23*) and the pilot valve (14) on the air motor base. Torque the pilot valve to 25 N•m (18 ft-lb).
3. If the piston was disassembled, reassemble the cap screw (22†), piston (19) and rod (4†), using Loctite® from the kit on threads. See FIG. 8. Make sure the flat side of the piston faces down. Torque the cap screw to 150-163 N•m (110-120 ft-lb).
4. Replace bearing (26*) and seal (28*).
5. Place the o-ring (27*) on the piston (19). Grease the piston rod (4†) and o-ring (27*), and carefully insert the piston rod through the hole in the base (13). Align the hole in the piston with the orientation bolt (15) in the base until the piston rests against the base.
6. Install lock washers (11) and screws (10). Torque to 10-11 N•m (90-100 in-lb).
7. Replace o-ring (1*).
8. Install the threaded insert (3) onto the end of the rod from the opposite end and tighten.
9. Generously grease the lower half of the cylinder's (21) inside surface. Install the cylinder and the side cover (20). See FIG. 8.
10. Install the o-ring (23*) and the pilot valve (14) on the inside surface of the bottom cover (32). Torque the pilot valve to 25 N•m (18 ft-lb). Lubricate the o-ring. Install the bottom cover (32), making sure the air valve porting (Y₁) faces the same way as the porting on the base (Y₂). Torque the screws (12) to 10-11 N•m (90-100 in-lb). See FIG. 8.
11. Reinstall the air valve with new gaskets (34*) (page 16).
12. Reconnect the displacement pump to the air motor (page 15).

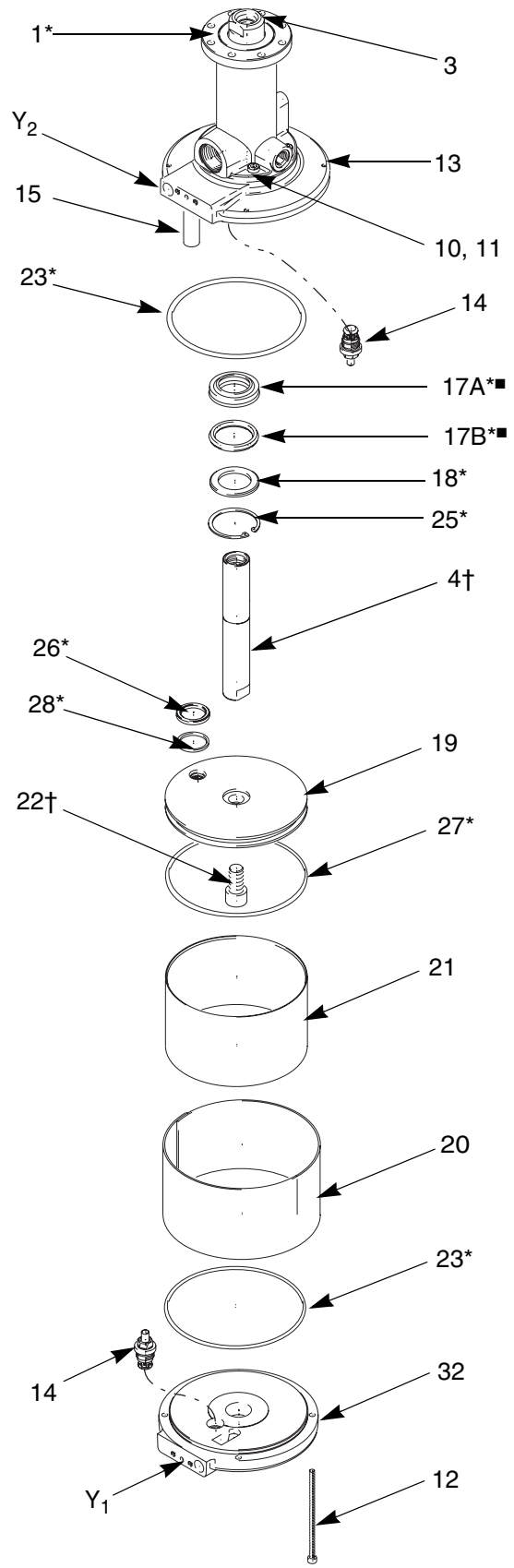

FIG. 8

Bellows Repair

- To repair the bellows, order repair kit 234043. Parts included in the kit are marked, for example (2[■]).
- Ring and Seal (17A[■] and 17B[■]) are included in the Bellows Repair Kit to be replaced if the bellows fails and fluid leaks into the seal area. See pages 17 and 18 for procedure.

CAUTION

- Never twist the bellows. The threaded connector should never be loosened until the housing has been removed. Conversely, the housing should never be installed until the bellows is securely attached to the piston rod with the threaded connector.

Disassembly

See FIG. 9.

1. Disconnect the air motor from the displacement pump. (See page 15).
2. Remove the housing (6) from the air motor by removing screws (10). Be careful not to lose the associated lock washers (11).
3. Pull on the threaded connector (3) to verify that the piston rod (4) is in its fully extended position.
4. Loosen and remove the threaded connector (3).
5. Remove bellows (5[■]) and o-rings (24[■], 2[■]) (FIG. 10).

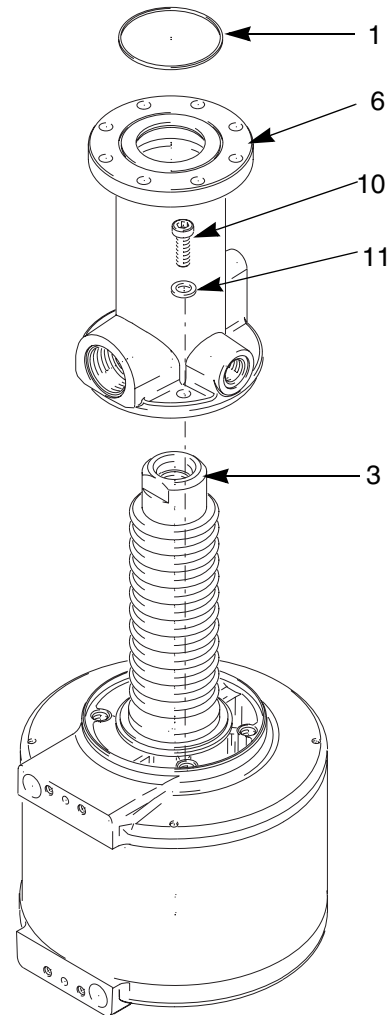

FIG. 9

Reassembly

See FIG. 10.

1. Replace the bellows (5 ■) and o-rings (24■, 2■) with parts from Bellows repair kit 234043.
2. Secure the bellows (5■) to the piston rod (4) by installing the threaded connector (3) onto the piston.
3. Install the housing (6). Torque screws (10) to 10-11 N•m (90-100 in-lb). Do not forget to include lock washers (11).
4. Reconnect the displacement pump

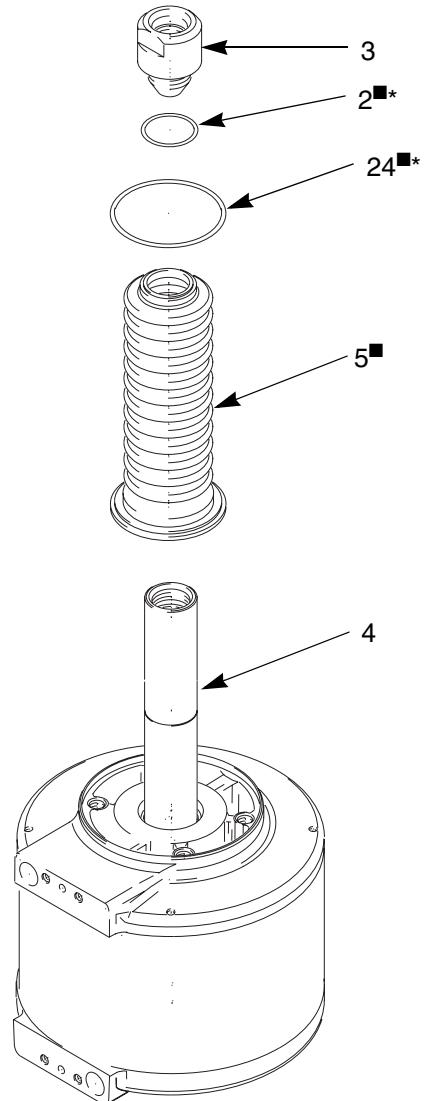



FIG. 10

Displacement Pump Repair

 Seal*, Packing**, and Valve♦ repair kits are available. See page 26 for part numbers.

Disassembly

1. Separate the air motor from the displacement pump. (See page 15.)
2. Loosen and remove screws (96). See FIG. 11.
3. Remove the valve housing (71). This allows access to the pressure valve. Evaluate the ball (72♦) and seat (77♦) and replace if worn.

 The valve seats are dual-sided and can be turned over and reused when one side is worn. The profile seal rings (75♦*) or (97♦*) and balls, should be replaced each time the seat is turned over or replaced.

4. Remove the cylinder (79).
5. Remove the piston assembly.

6. Remove piston valve (91) from the piston. Be careful not to damage the surface of the piston during repair and maintenance work. Use only the flats (Z) to prevent the piston from rotating when removing the screw. (See FIG. 12.)
7. Note the positions and orientations of the guide ring (76**), the U-cup (92**), and the sealing ring (94) assembled onto piston valve (91). Remove these parts and replace with parts from the appropriate Packing Repair Kit (page 26).
8. Suction valve parts are now accessible. Evaluate the ball (72♦) and seat (77♦) and replace if worn.
9. Remove the sealing ring (93**) from inside the piston (95) and replace.
10. Note the positions and orientations of the packing retainer (85), the flat seal (84**), the guide ring (82**) and the U-cup (81**) as you remove them from the packing housing (83). Replace the soft parts with those included in the packing repair kit. See FIG. 13.

 For replacement of seal (88*), see exploded view on page 27.

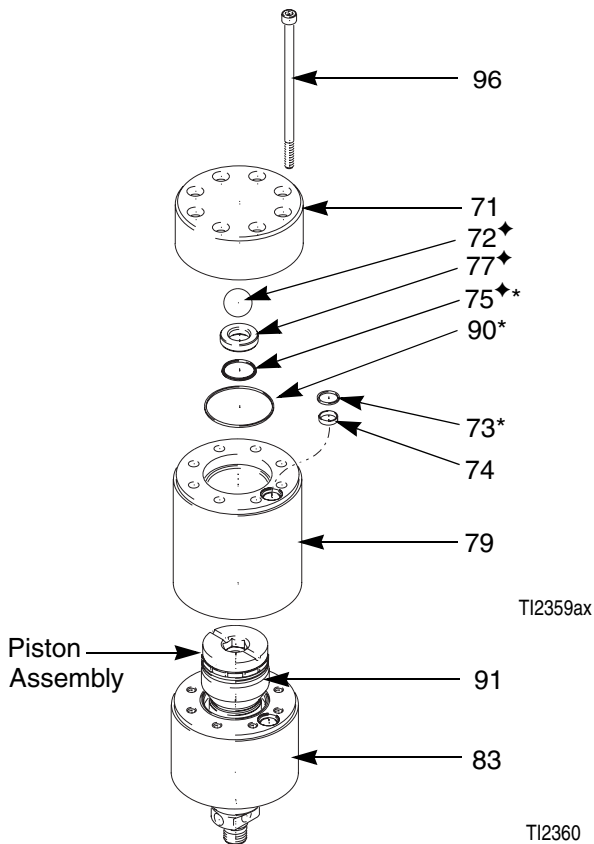

FIG. 11

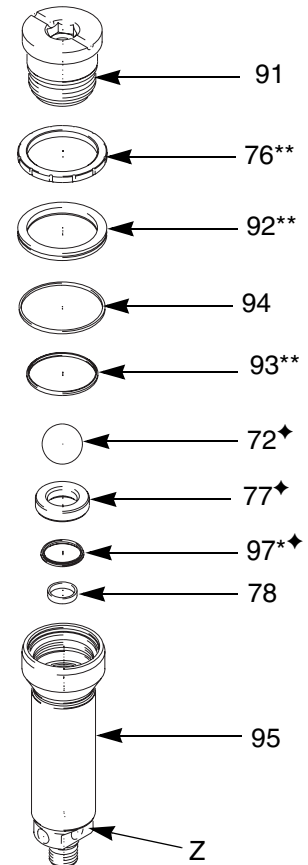

FIG. 12 Piston Assembly Breakdown

Reassembly

1. Insert the U-cup (81**), guide ring (82**), flat seal (84**), and packing retainer (85) into the packing housing (83). See FIG. 13.
2. Insert the sealing ring (93**) into the piston (95). Replace the piston (95) if it shows signs of wear. Check that ring (78) is in place. See FIG. 12.
3. Verify correct assembly of suction valve parts (97***, 77**, and 72**). See FIG. 12.
4. Assemble the guide ring (76**), U-cup (92**), and sealing ring (94) on the piston valve (91). See FIG. 12.
5. Install the piston valve (91) onto the piston (95). Retighten the piston valve (91) firmly. See FIG. 12.
6. Install the piston assembly into the packing housing (83). Install seals (80*, 74, and 73*) into valve housing (83). Replace seals 73* and 80* as necessary. See FIG. 11.
7. Install the cylinder (79). Replace the cylinder if it shows signs of wear.
8. Install seals (90*, 74, and 73*) into the cylinder (79). Replace seals (90* and 73*) as necessary.
9. Verify correct assembly of pressure valve parts (75**, 77**, and 72**).
10. Install the valve housing (71).
11. Install screws (96) and torque to 24.4-25.8 N•m (216-228 in-lb).

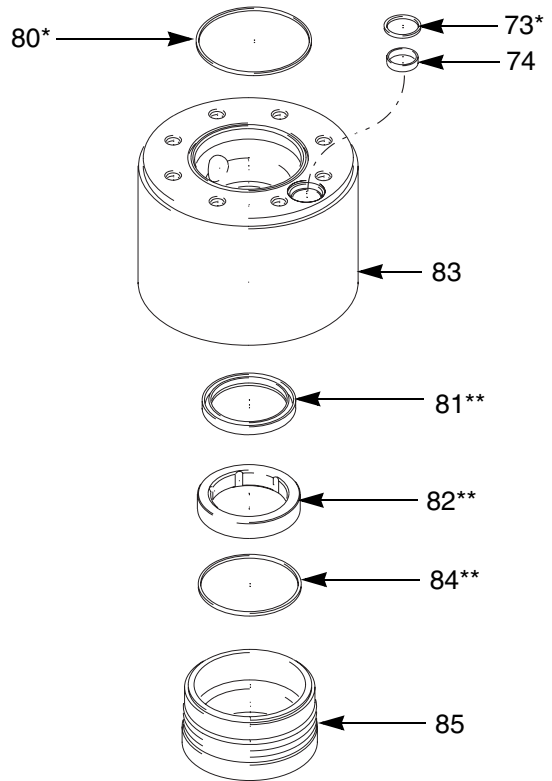



FIG. 13

 The cylinder (79) and valve housing (71) can be oriented in any way relative to each other and to the packing housing (83) to provide any configuration of inlet and outlet desired.

12. Connect the Displacement pump to the Air Motor.

Parts

Complete Pump

Part Nos. 245934, 245935, 234084, 234085

Ref. No.	Part No.	Description	Qty	Ref. No.	Part No.	Description	Qty
101		PUMP, lower, 028.050 for 234085 and 245934	1	206994		FLUID, tsl, 8 ounce bottle	1
		PUMP, lower, 015.085 for 234084 and 245935	1	113	245682	ADAPTER, assembly for 245934 and 245935	1
102		MOTOR, air, Orion	1	245718		ADAPTER, assembly for 234084 and 234085	1
103	117379	SCREW, cap	8	114▲	196155	LABEL, warning	1
104	117380	WASHER, lock	8	115	15B525	FITTING, adapter, npt for 234084 and 234085	1
				116	234083	ADAPTER, assembly for 234084 and 234085	1
106	117237	MUFFLER	1				

▲ Replacement warning labels, signs, tags, and cards are available at no cost.

△1 Torque to 25 N•m (18 in-lb)

△2 When connecting the threaded piston in the pump to the threaded insert in the air motor,

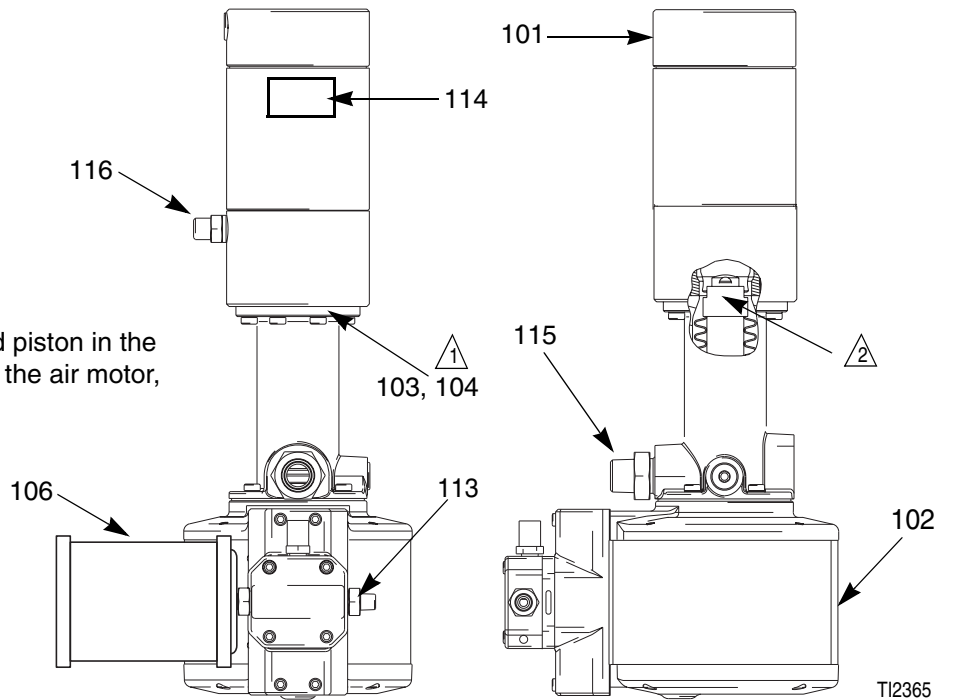

Air Motor

Ref. No.	Part No.	Description	Qty	Ref. No.	Part No.	Description	Qty
1*		SEAL, flat, UHMWPE	1	25*		RING, retaining, internal	1
2* ■		O-RING	1	26*		BEARING	1
3	15B001	INSERT, threaded	1	27*		O-RING	1
4†		ROD, piston	1	28*		SEAL, quad ring	1
5■		BELLOWS	1	29	15A110	HOUSING, air valve	1
6	15B915	HOUSING	1	32	15A140	COVER, cylinder D160	1
8	116343	CLAMP, grounding	1	34*‡		GASKET, air valve	2
9	111307	WASHER (used with #8, 116343)	1	35	117079	SCREW, shcs M6x50	4
10	117379	SCREW, cap	4	36*		SEAL, ring	1
11	117380	WASHER, lock	4	37	116902	PLUG, socket head (DIN908)	1
12	117084	SCREW, shcs M6x125	4	38*		PIN	1
13		COVER, cylinder	1	40‡		CARRIAGE, driver	1
14	245350	VALVE, pilot	2	43‡		CUP, air valve	1
15	117400	BOLT, orientation	1	44‡		SEAT, air valve	1
17A*■		RING	1	45	15A053	COVER, air valve	1
17B*■		SEAL	1	46	117078	SCREW, shcs (M6x45)	4
18*		WASHER	1	47	117052	SCREW, set M6x12	1
19	15B005	DISK, piston	1	50	15A056	BUSHING, air valve	2
20	15A925	COVER, round	1	51*‡		O-RING	4
21	15A136	CYLINDER, D160	1	60	197660	VALVE, safety, air	1
22†		SCREW, shcs M16x30 with patch	1	69	117377	SCREW, set, cup pt.	2
23*		O-RING	2				
24* ■		O-RING	1				

Air Motor Repair Kits

*	Air motor seal repair kit	234041
†	Air motor piston repair kit	234042
■	Bellows repair kit	234043
‡	Air valve repair kit	233836

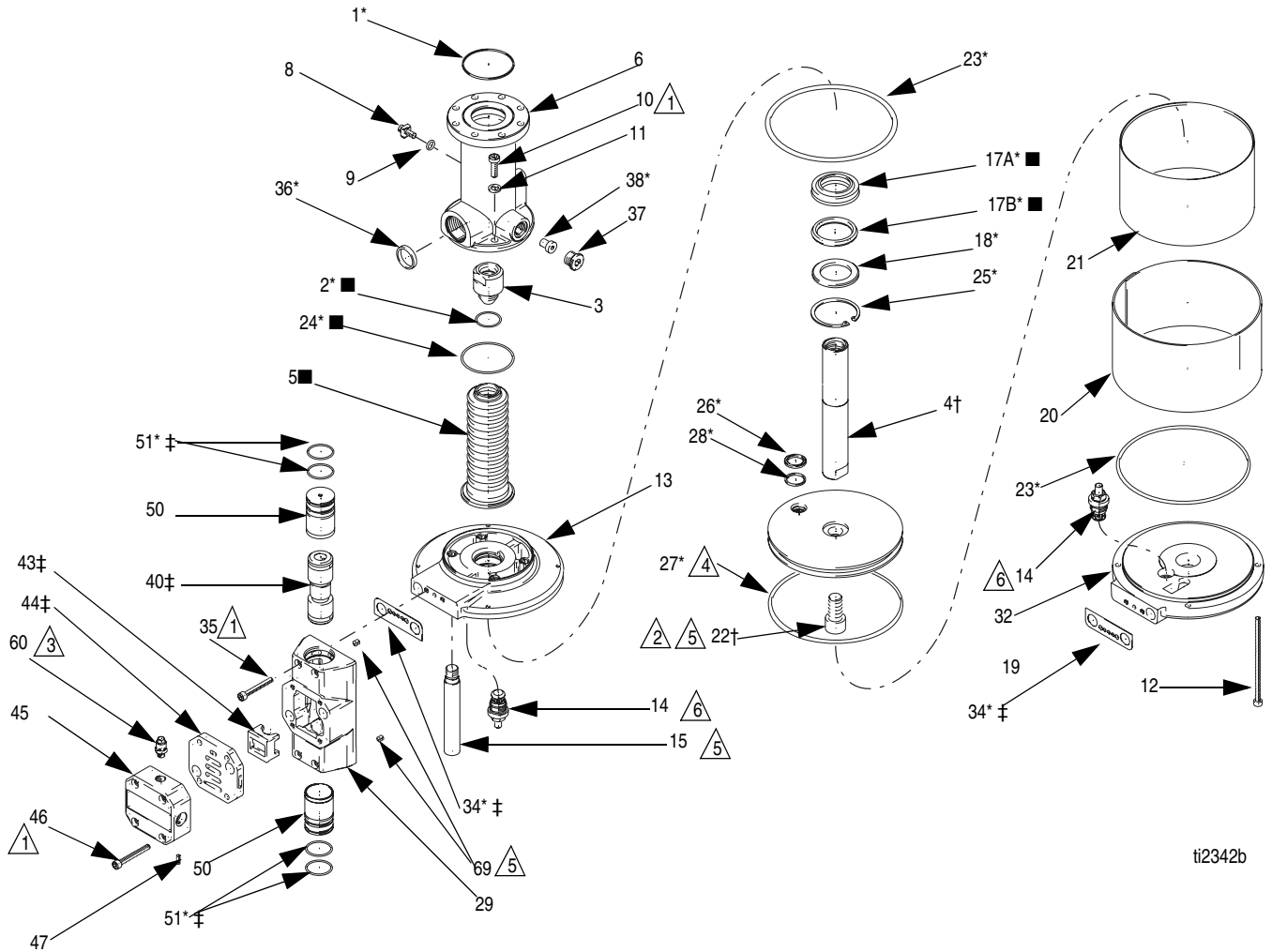

ti2342b

- △1 Torque to 10-11 N•m (90-100 in-lb)
- △2 Torque to 150-163 N•m (110-120 ft-lb)
- △3 Apply sealant
- △4 Apply grease
- △5 Assemble with Loctite
- △6 Torque to 25 N•m (18 ft-lb)

Pump Lowers

028.050 and 015.085

Ref. No.	Part No.	Description	Qty	Ref. No.	Part No.	Description	Qty
71	15A992	HOUSING, valve (028.050)	1	84**		SEAL, flat, UHMWPE (028.050)	1
	15B008	HOUSING, valve (015.085)	1			SEAL, flat, UHMWPE (015.085)	1
72◆		BALL, 18mm (028.050)	2	85	15A996	RETAINER, packing (028.050)	1
		BALL, 25mm (015.085)	2		15B017	RETAINER, packing (015.085)	1
73*		SEAL, flat, UHMWPE	2	86	15A997	HOUSING, valve seat (028.050)	1
74	15B009	RING, seal	2		15B018	HOUSING, valve seat (015.085)	1
75*◆		SEAL, profile (015.085)	1	87	117412	PIN	1
76**		GUIDE, ring (028.050)	1	88*		SEAL, flat	1
		GUIDE, ring (015.085)	1	89	116902	PLUG, socket head (DIN908)	1
77◆		SEAT, valve (028.050)	2	90*		SEAL, flat, UHMWPE (028.050)	1
		SEAT, valve, D20 (015.085)	2			SEAL, flat, UHMWPE (015.085)	1
78	15A993	RING (028.050)	1	91	15A998	VALVE, piston (028.050)	1
	15B011	RING (015.085)	1		15B019	VALVE, piston (015.085)	1
79	15A994	CYLINDER, piston (028.050)	1	92**		PACKING, u-cup (028.050)	1
	15B012	CYLINDER, piston (015.085)	1			PACKING, u-cup (015.085)	1
80*		SEAL, flat, UHMWPE (028.050)	1	93**		RING, sealing (028.050)	1
		SEAL, flat, UHMWPE (015.085)	1			RING, sealing (015.085)	1
81**		PACKING, u-cup (028.050)	1	94	15A999	RING, sealing (028.050)	1
		PACKING, u-cup (015.085)	1		117550	RING, sealing (015.085)	1
82**		GUIDE, ring (028.050)	1	95	15B015	PISTON (028.050)	1
		GUIDE, ring (015.085)	1		15B013	PISTON (015.085)	1
83	15A995	PACKING, housing (028.050)	1	96	15B023	SCREW, cap	8
	15B016	HOUSING, valve (015.085)	1	97*◆		RING, sealing (028.050)	2
						RING, sealing (015.085)	1

Displacement Pump Repair Kits

Displacement Pump	* Seal Repair Kit	◆ Ball and Seat Repair Kit	** Packing Repair Kit
028.050	234049	234045	234047
015.085	234048	234044	234046

Parts

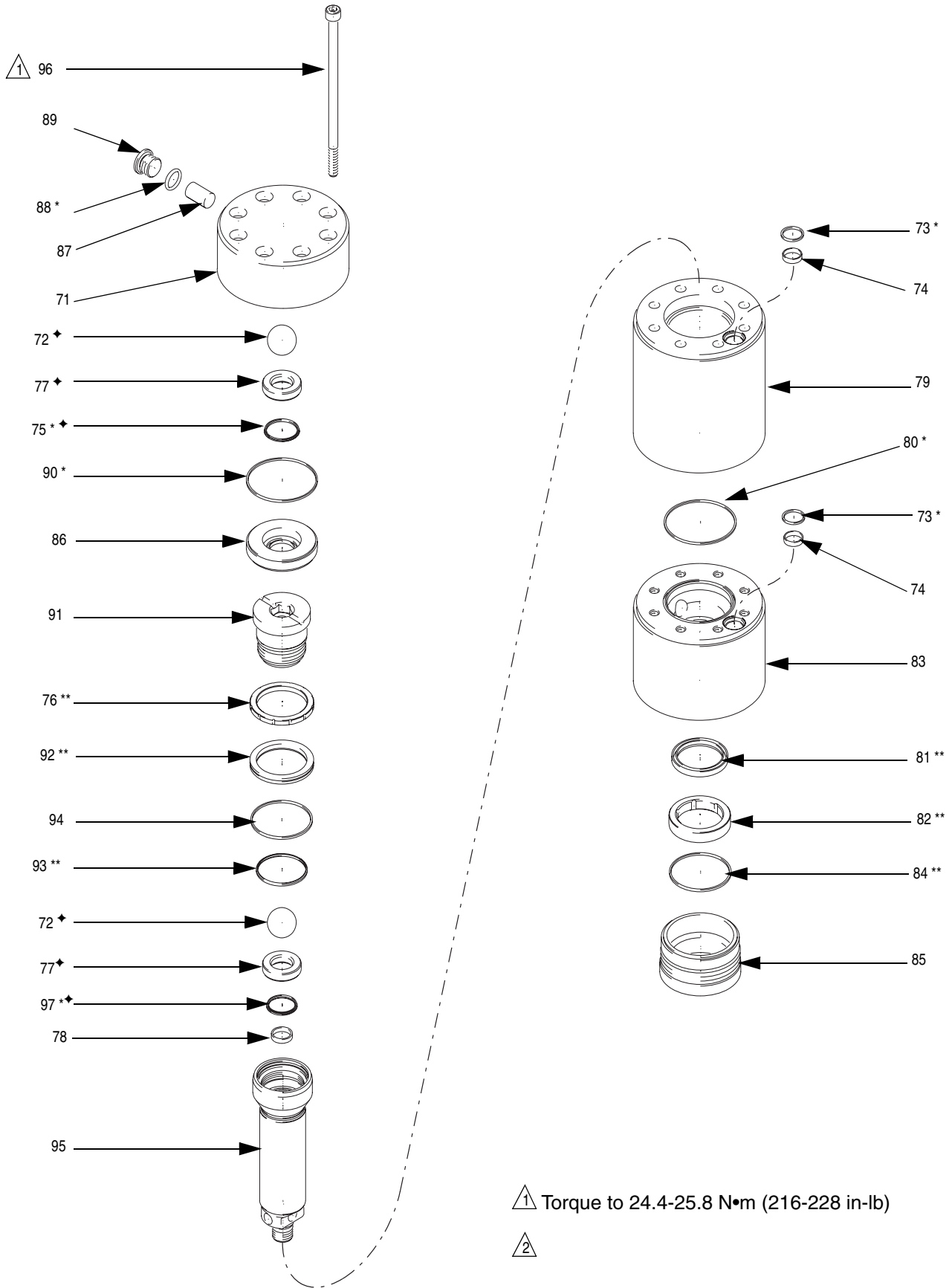

Wall Mount Packages

234087 (015.085) and 234089 (028.050)

 See pages 30 and 35 for air control details.

Ref. No.	Part No.	Description	Qty	Ref. No.	Part No.	Description	Qty
				209	245723	CONTROL, air	1
201	100186	WASHER, lock, internal tooth	2	210	234084	PUMP. 015.085, Orion, bare, npt (234087)	1
202	115264	SCREW, cap, socket head	2		234085	PUMP. 028.050, Orion, bare, npt (234089)	1
203	117351	PLATE, formed	1	211	238909	Wire, grounding	1
206	223160	FILTER, fluid	1				
208	235208	FITTING, union, swivel	1				

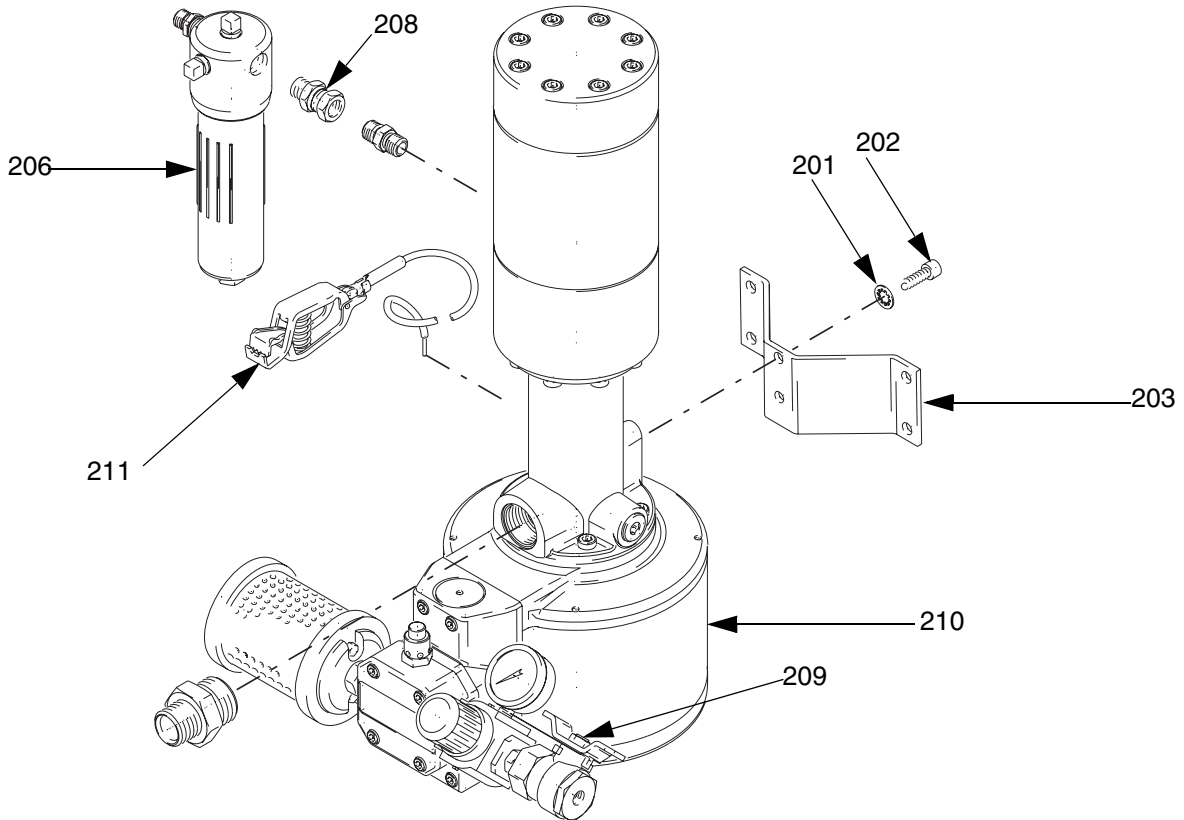

Cart Mount Packages

Part Nos. 234091 (015.085) and 234093 (028.050)



See pages 30 and 35 for Air Control details.

Ref. No.	Part No.	Description	Qty
301	100186	WASHER, lock, internal tooth	2
302	117368	SCREW, cap, socket head	2
303	15A796	BLOCK, mounting	1
305	223160	FILTER, fluid	1
307	235208	FITTING, union, swivel	1
308	243606	CART, Falcon, 2 wheel	1
309	245723	CONTROL, air	1
310	234084	PUMP, 015.085, Orion, bare, npt (234091)	1
	234085	PUMP, 028.050, Orion, bare, npt (234093)	1
311	238909	WIRE, grounding	1

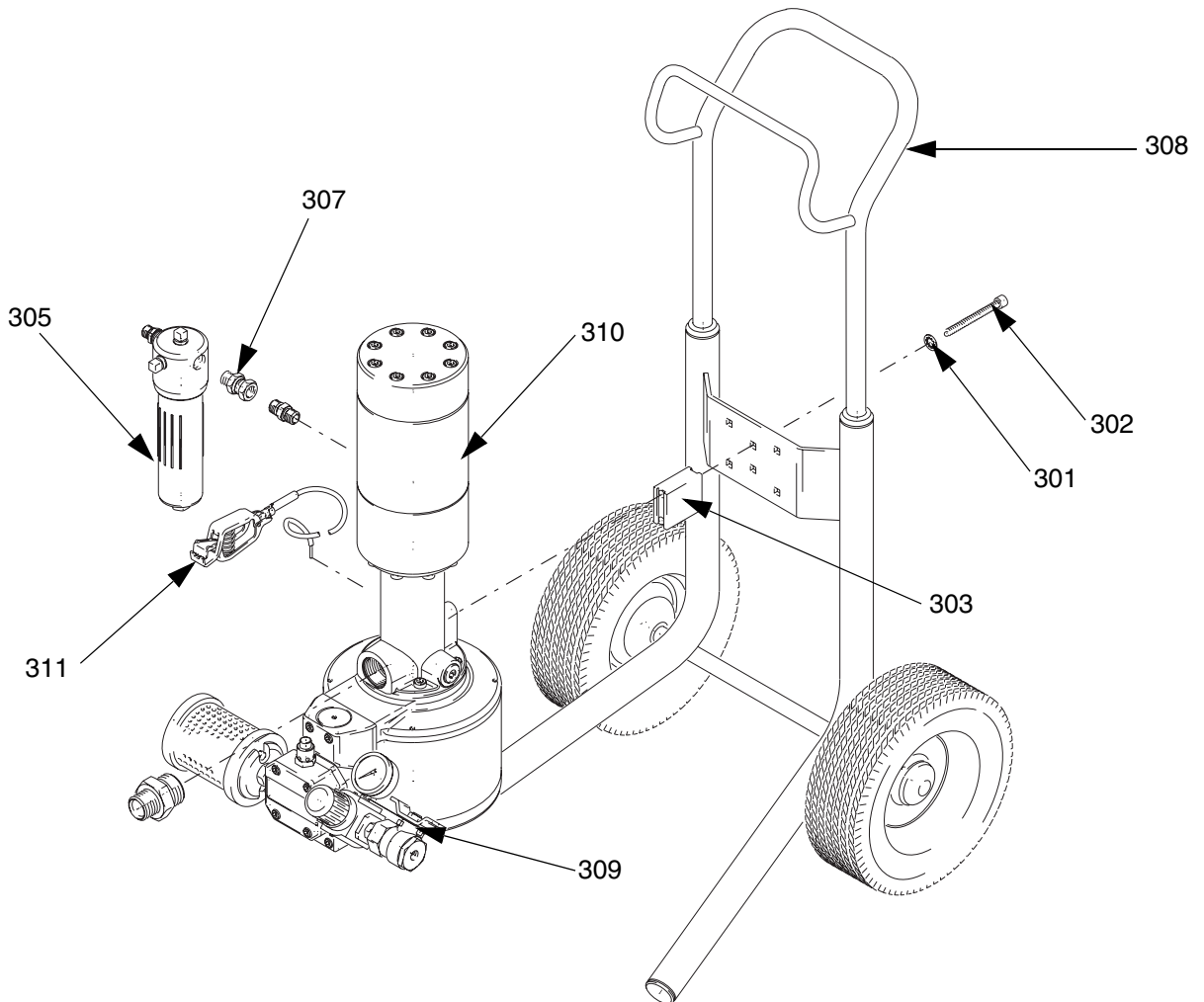

Air Inlet Details

245723 Single Air Control Kit, used on all packages

Ref. No.	Part No.	Description	Qty
400	245723	CONTROL, air; includes items:	1
401	116513	. AIR REGULATOR	1
402	110436	. GAUGE, air	1
403	116473	. VALVE, air, bleed-type; 1/4 npt (fbe)	1
404	245718	. ADAPTER; 1/4 npt(m); includes item 104a	1
404a	117114	. O-RING	1
407	156971	. NIPPLE; 1/4 npt	1

245682 Air Inlet Adapter, used on bare pumps 245934 and 245935

Ref. No.	Part No.	Description	Qty
404	245682	ADAPTER; 3/8 bspp(m); includes items 104a and 104b	1
404a	117114	. O-RING	1
404b	117001	. SEAL, flat	1

245718 Air Inlet Adapter, used on bare pumps 234084 and 234085

Ref. No.	Part No.	Description	Qty
404	245718	ADAPTER; 1/4 npt(m); includes item 104a only	1
404a	117114	. O-RING	1

Accessories

Part No. Description

245682	Air inlet adapter (3/8 BSPP x 15.5 mm)
245718	Air inlet adapter (1/4 npt x 15.5 mm)
15B525	Pump inlet adapter (1 BSPP x 3/4 npt)
15B284	Pump inlet fitting (1 BSPP x 22 mm tube)
15B285	Pump inlet fitting (1 BSPP x 28 mm tube)
234083	Pump outlet adapter (3/8 npt x 3/8 bspt)
15B282	Suction hose, 30 liter, 28 mm
15B526	Siphon hose kit, 30 liter with 28 mm adapter
15B283	Suction hose, 200 liter, 28 mm
15B527	Siphon hose kit, 200 liter with 28 mm adapter
245717	5 liter stainless steel cup
15B528	5 liter stainless steel cup with 22 mm adapter
246300	AA gun suction kit
246301	Airless gun suction kit
245724	30 liter, 22 mm suction hose
245737	200 liter, 22 mm suction hose

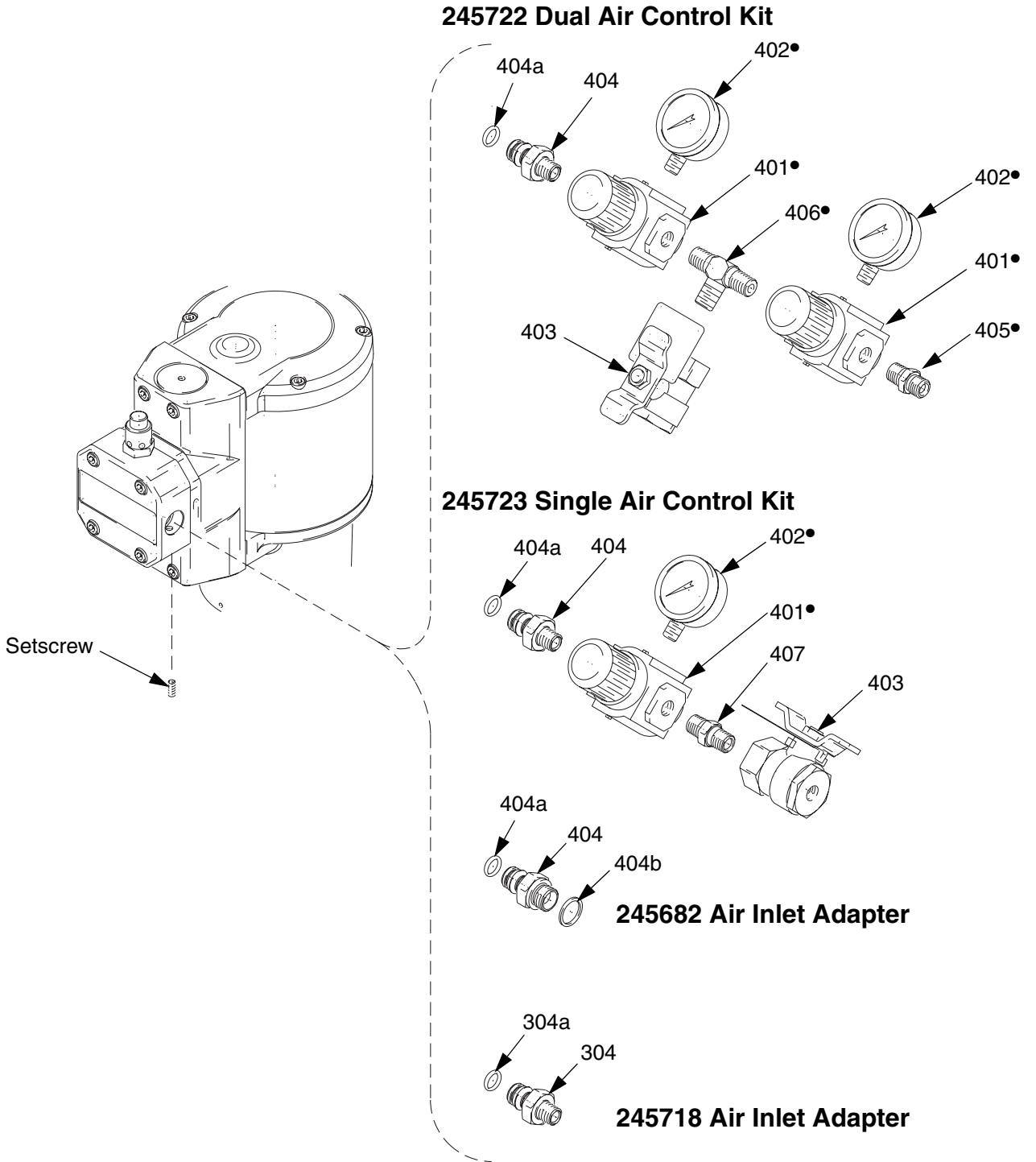

TI2107A

Gun/Siphon Hose Kits

Alpha+ (246300)

Ref. No.	Part No.	Description	Qty	Ref. No.	Part No.	Description	Qty
501	243573	GUN, assembly, Alpha Plus	1	401•		REGULATOR, air	1
503	GG4XXXOPTION	tip	1	402•		GAUGE, pressure, air	1
504	239107	HOSE, coupled, 6.3mm, 1/4"	1	405•		NIPPLE (1/4 npsm x 1/4 npt)	1
505	241811	HOSE, coupled, 25 ft.	1	406•		FITTING, tee, 1/4 npt	1
506	15B526	KIT, accessory, siphon, 30L	1	507•		LABEL, icon, gun	1

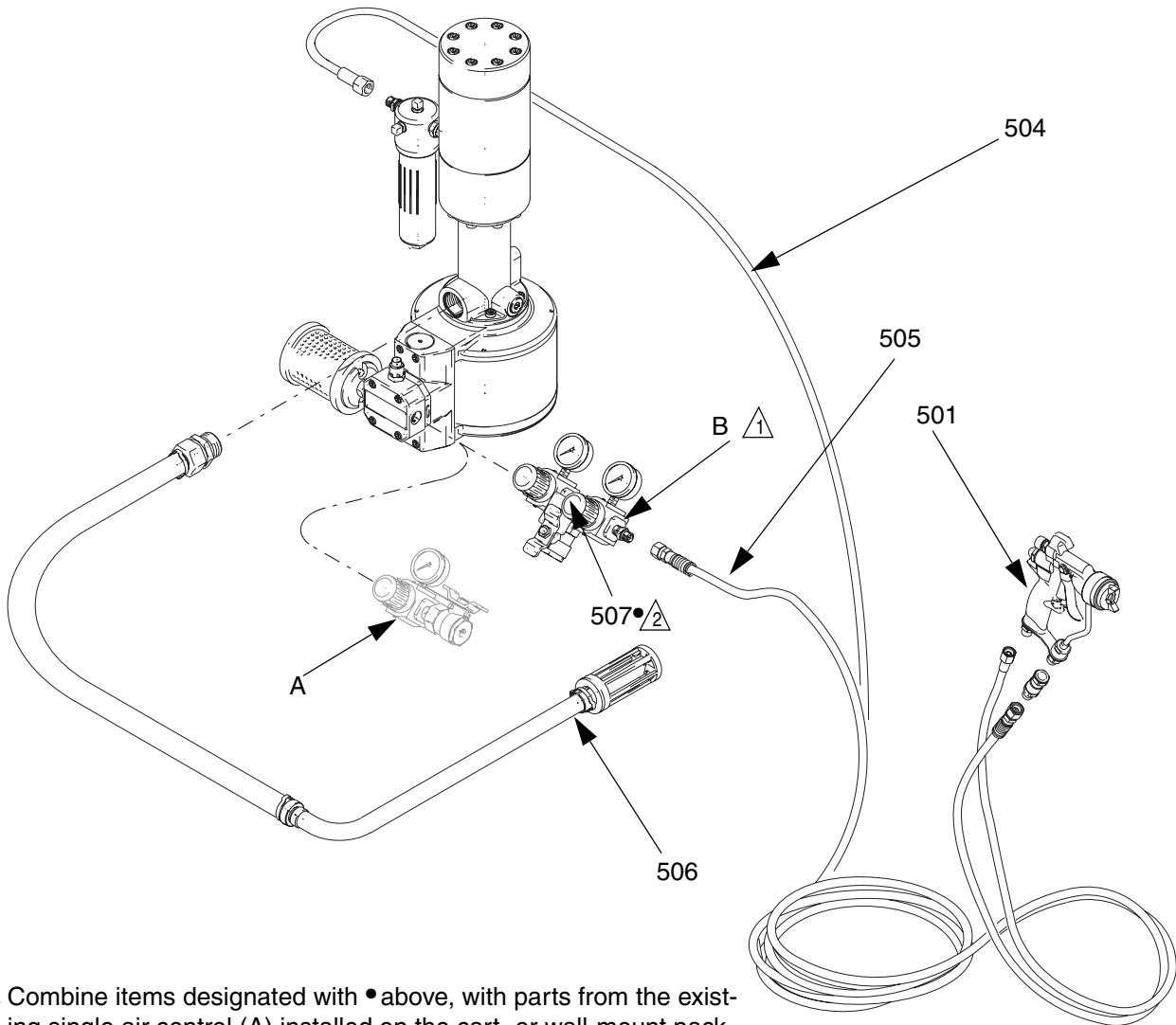

△¹ Combine items designated with • above, with parts from the existing single air control (A) installed on the cart- or wall-mount package, to build dual air control (B). See pages 34 and 35 for assembly details.

Note that nipple (407) provided in air control (A) will not be used in the final air control (B).

△² Attach gun icon label (507•) to face of regulator knob as shown.

Silver+ (246301)

Ref. No.	Part No.	Description	Qty
601	235462	GUN, assembly, Silver	1
603	163XXX	OPTION, tip	1
604	239107	HOSE, coupled, 6.3mm, 1/4"	1
606	15B526	KIT, accessory, siphon, 30L	1

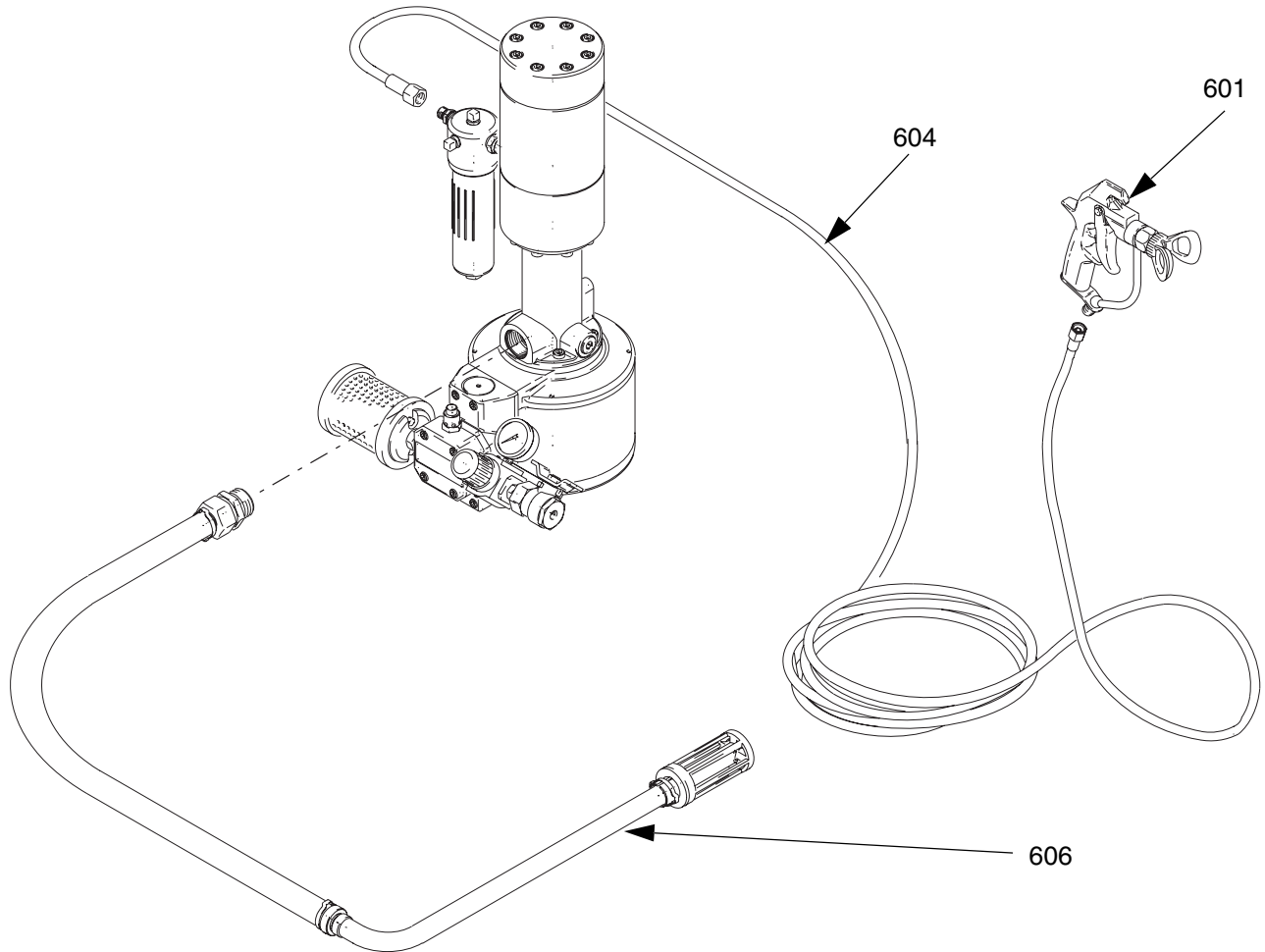

Technical Data

Category	Data
Maximum fluid working pressure	015.085-DP 1740 psi (120 bar, 12.0 MPa) 028.050-DP 3248 psi (224 bar, 22.4 MPa)
Maximum air input pressure	116 psi (8 bar, 0.8 MPa)
Minimum air input pressure	7 psi (0.5 bar, 0.05 MPa)
Ratio	015.085-DP 15:1 028.050-DP 28:1
Volume per stroke	015.085-DP 2.8 oz (85 cc) 028.050-DP 1.7 oz (50 cc)
Fluid flow at 60 cycles per minute	015.085-DP 10.2 l/min 028.050-DP 6 l/min
Operating temperature range	10-80°C (50-176°F)
Maximum cycle rate continuous use	Full load 14 cycles/minute Partial load 18 cycles/minute
Maximum cycle rate intermittent load	Full load 30 cycles/minute Partial load 45 cycles/minute
Air motor piston diameter	6.3 in (160 mm)
Stroke length	2.75 in (70 mm)
Displacement pump effective area	015.085-DP 1.9 in ² (12 cm ²) 028.050-DP 1.1 in ² (7 cm ²)
Wetted parts	SST, UHMWPE, carbide, fluoroelastomer, PTFE, Acetal

Loctite® is a registered trademark of the Loctite Corporation.

Sound Pressure Levels in dB(A), measured at 1 m from equipment

Air Motor	Input Air Pressure			
	0.2 MPa, 2 bar (29 psi)	0.4 MPa, 4 bar (58 psi)	0.6 MPa, 6 bar (87 psi)	0.8 MPa, 8 bar (116 psi)
233948 (D160)	78	82	85	89

Performance Charts

Part Nos. 234084 and 245935, 15:1 Ratio

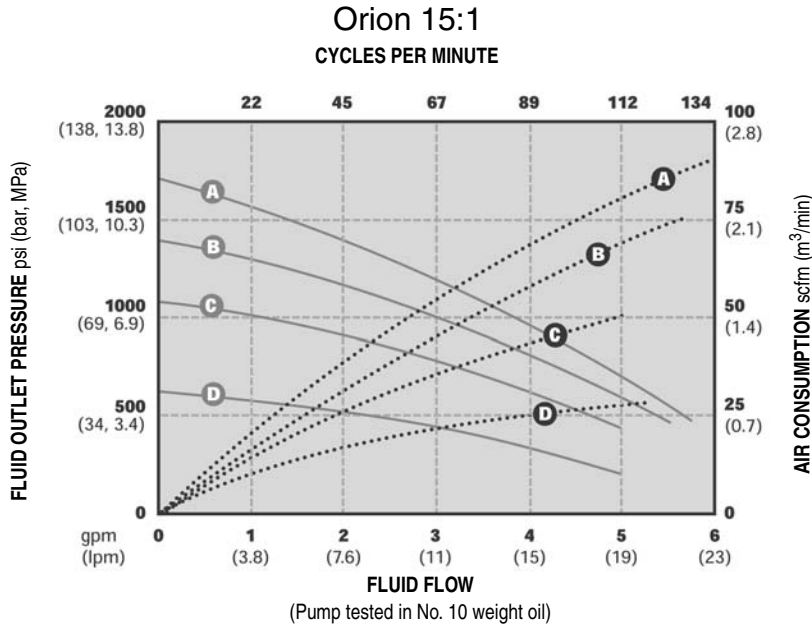

Key

A = 115 psi (7.9 bar, 0.79 MPa)
B = 90 ps (6.2 bar, 0.69 MPa)
C = 70 psi (4.8 bar, 0.48 MPa)
D = 40 psi (2.8 bar, 0.28 MPa)
Fluid Flow _____
Air Consumption.....

Part Nos. 234085 and 245934, 28:1 Ratio

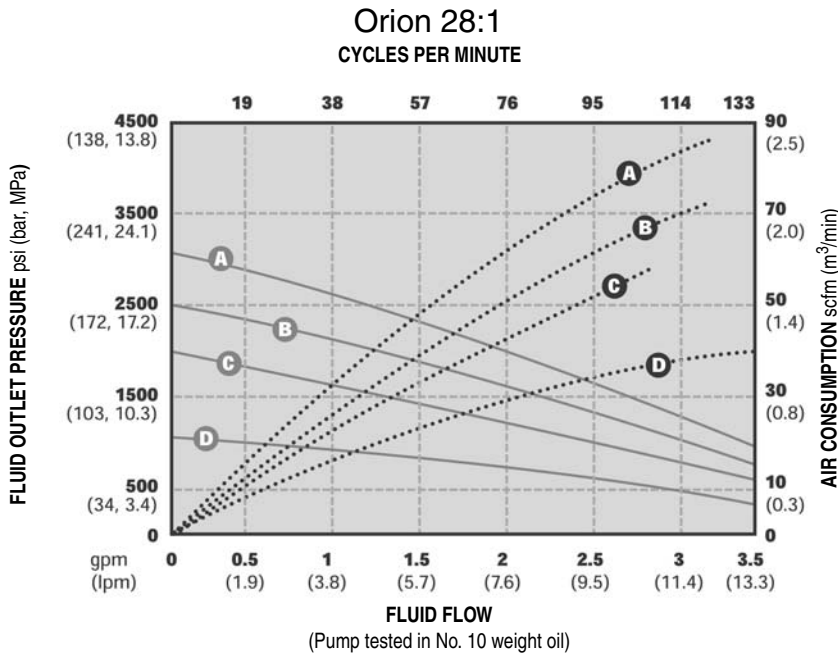

Key

A = 115 psi (7.9 bar, 0.79 MPa)
B = 90 ps (6.2 bar, 0.69 MPa)
C = 70 psi (4.8 bar, 0.48 MPa)
D = 40 psi (2.8 bar, 0.28 MPa)
Fluid Flow _____
Air Consumption

Dimensions

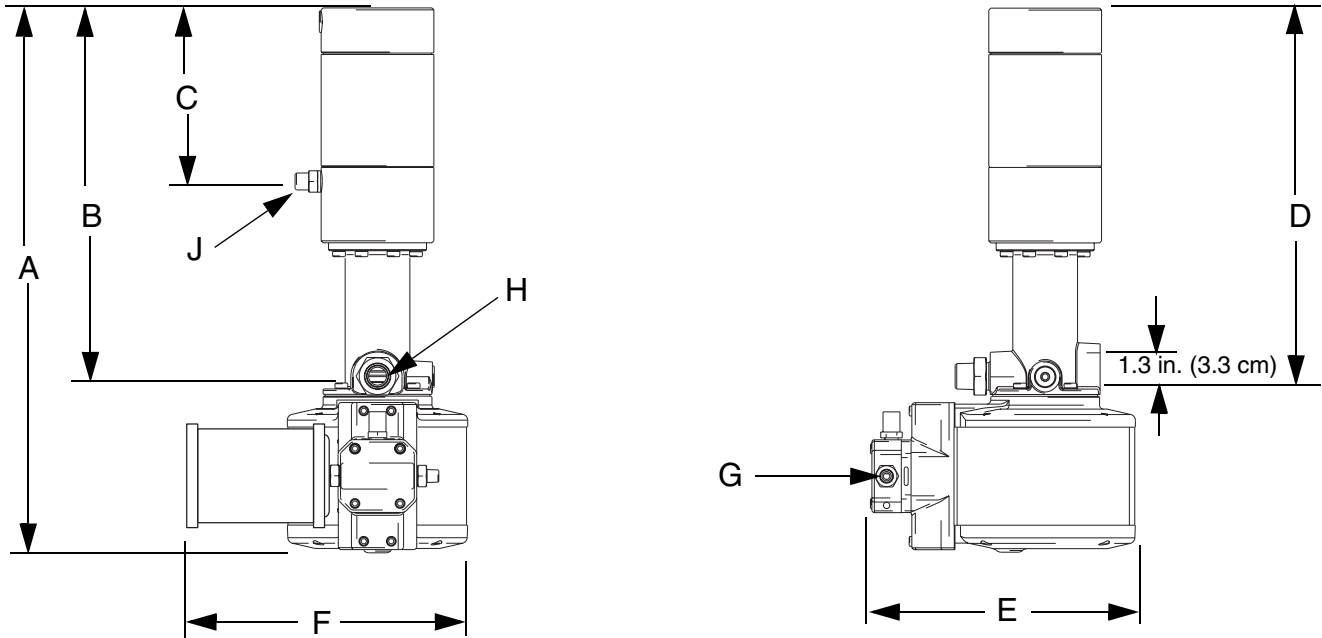

Pump Model	Weight lb (kg)	A in. (cm)	B in. (cm)	C in. (cm)	D in. (cm)	E in. (cm)	F in. (cm)	G: Air Inlet Size	H: Fluid Inlet Size	J: Fluid Out- let Size
245934	58 (26.4)	21.2 (53.9)	14.3 (36.4)	6.7 (16.95)	14.7 (37.3)	10.6 (27)	10.5 (26.6)	3/8 BSPP (m)	1 BSPP (f)	3/8 BSPP (f)
245935	66 (30.0)	21.7 (55.2)	14.8 (37.7)	7.0 (17.8)	15.2 (38.55)	10.6 (27)	10.5 (26.6)	3/8 BSPP (m)	1 BSPP (f)	3/8 BSPP (f)
234084	66 (30.0)	21.7 (55.2)	14.8 (37.7)	7.0 (17.8)	15.2 (38.55)	10.6 (27)	10.5 (26.6)	1/4 npt (m)	3/4 npt (m)	3/8 npt (m)
234085	58 (26.4)	21.2 (53.9)	14.3 (36.4)	6.7 (16.95)	14.7 (37.3)	10.6 (27)	10.5 (26.6)	1/4 np (m)	3/4 npt (m)	3/8 npt (m)



A series of horizontal lines for writing, starting from the top line and extending down to the bottom of the page.

Graco Warranty

Graco warrants all equipment referenced in this document which is manufactured by Graco and bearing its name to be free from defects in material and workmanship on the date of sale to the original purchaser for use. With the exception of any special, extended, or limited warranty published by Graco, Graco will, for a period of twelve months from the date of sale, repair or replace any part of the equipment determined by Graco to be defective. This warranty applies only when the equipment is installed, operated and maintained in accordance with Graco's written recommendations.

This warranty does not cover, and Graco shall not be liable for general wear and tear, or any malfunction, damage or wear caused by faulty installation, misapplication, abrasion, corrosion, inadequate or improper maintenance, negligence, accident, tampering, or substitution of non-Graco component parts. Nor shall Graco be liable for malfunction, damage or wear caused by the incompatibility of Graco equipment with structures, accessories, equipment or materials not supplied by Graco, or the improper design, manufacture, installation, operation or maintenance of structures, accessories, equipment or materials not supplied by Graco.

This warranty is conditioned upon the prepaid return of the equipment claimed to be defective to an authorized Graco distributor for verification of the claimed defect. If the claimed defect is verified, Graco will repair or replace free of charge any defective parts. The equipment will be returned to the original purchaser transportation prepaid. If inspection of the equipment does not disclose any defect in material or workmanship, repairs will be made at a reasonable charge, which charges may include the costs of parts, labor, and transportation.

THIS WARRANTY IS EXCLUSIVE, AND IS IN LIEU OF ANY OTHER WARRANTIES, EXPRESS OR IMPLIED, INCLUDING BUT NOT LIMITED TO WARRANTY OF MERCHANTABILITY OR WARRANTY OF FITNESS FOR A PARTICULAR PURPOSE.

Graco's sole obligation and buyer's sole remedy for any breach of warranty shall be as set forth above. The buyer agrees that no other remedy (including, but not limited to, incidental or consequential damages for lost profits, lost sales, injury to person or property, or any other incidental or consequential loss) shall be available. Any action for breach of warranty must be brought within two (2) years of the date of sale.

GRACO MAKES NO WARRANTY, AND DISCLAIMS ALL IMPLIED WARRANTIES OF MERCHANTABILITY AND FITNESS FOR A PARTICULAR PURPOSE, IN CONNECTION WITH ACCESSORIES, EQUIPMENT, MATERIALS OR COMPONENTS SOLD BUT NOT MANUFACTURED BY GRACO. These items sold, but not manufactured by Graco (such as electric motors, switches, hose, etc.), are subject to the warranty, if any, of their manufacturer. Graco will provide purchaser with reasonable assistance in making any claim for breach of these warranties.

In no event will Graco be liable for indirect, incidental, special or consequential damages resulting from Graco supplying equipment hereunder, or the furnishing, performance, or use of any products or other goods sold hereto, whether due to a breach of contract, breach of warranty, the negligence of Graco, or otherwise.

FOR GRACO CANADA CUSTOMERS

The Parties acknowledge that they have required that the present document, as well as all documents, notices and legal proceedings entered into, given or instituted pursuant hereto or relating directly or indirectly hereto, be drawn up in English. Les parties reconnaissent avoir convenu que la rédaction du présente document sera en Anglais, ainsi que tous documents, avis et procédures judiciaires exécutés, donnés ou intentés, à la suite de ou en rapport, directement ou indirectement, avec les procédures concernées.

Graco Phone Numbers

TO PLACE AN ORDER, contact your Graco distributor, or call this number to identify the distributor closest to you:

1-800-328-0211 Toll Free

612-623-6921

612-378-3505 Fax

All written and visual data contained in this document reflects the latest product information available at the time of publication. Graco reserves the right to make changes at any time without notice.

This manual contains English. MM 309512

Graco Headquarters: Minneapolis

International Offices: Belgium Korea, China, Japan

GRACO INC. P.O. BOX 1441 MINNEAPOLIS, MN 55440-1441

www.graco.com

10/2002, Revised 03/2007