

Husky™ Sanitary Series FDA-Compliant Diaphragm Pump

309528 rev.L

120 psi (0.8 MPa, 8 bar) Maximum Fluid Working Pressure
120 psi (0.8 MPa, 8 bar) Maximum Air Input Pressure



Important Safety Instructions

Read all warnings and instructions in this manual.
Save these instructions.

See page 3 for List of Models

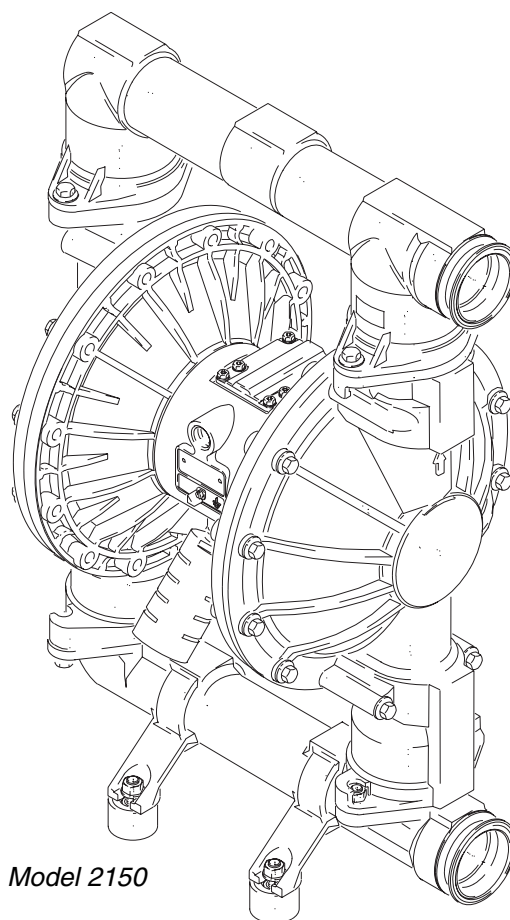

Model 2150

T12238

Patent No.
CN ZL94102643.4
FR 9408894
JA 3517270
US 5,368,452

PROVEN QUALITY. LEADING TECHNOLOGY.

Contents

Models	3	Pump Matrix - 1590	34
Manual Conventions	3	Repair Kit Matrix - 1590	35
Installation	6	Parts - 1590	36
Operation	11	Dimensional Drawing - 1590	39
Maintenance	13	Technical Data - 1590	40
Troubleshooting	14	Performance Chart - 1590	41
Service	16	Pump Matrix - 2150	42
Torque Sequence	24	Repair Kit Matrix - 2150	43
1040	24	Parts - 2150	44
1590	24	Model 234361	45
2150	25	Model 234362	45
Pump Matrix - 1040	26	Dimensional Drawing - 2150	49
Repair Kit Matrix - 1040	27	Technical Data - 2150	50
Parts - 1040	28	Performance Chart - 2150	51
Dimensional Drawing - 1040	31	Graco Warranties	52
Technical Data - 1040	32	Graco Information	52
Performance Chart - 1040	33		

Models

Refer to your Pump Matrix on page 26, 34, or 42 to determine the model number of your pump.



Model No.	Description
D7S_____	Husky 1040 FDA
D8S_____	Husky 1040 FDA Remote Operated
†DRS_____	Husky 1040 FDA Plus
†DSS_____	Husky 1040 FDA Plus Remote Operated
DBS_____	Husky 1590 FDA
DCS_____	Husky 1590 FDA Remote Operated
†DTS_____	Husky 1590 FDA Plus
†DUS_____	Husky 1590 FDA Plus Remote Operated
DFS_____	Husky 2150 FDA
DGS_____	Husky 2150 FDA Remote Operated
†DVS_____	Husky 2150 FDA Plus
†DWS_____	Husky 2150 FDA Plus Remote Operated

† Plus models include stainless steel center sections.

Manual Conventions

Warning

 **WARNING**

A warning alerts you to the possibility of serious injury or death if you do not follow the instructions.

Symbols, such as fire and explosion (shown above), alert you to a specific hazard and direct you to read the indicated hazard warnings (pages 4-5) for detailed information.

Caution

 **CAUTION**

A caution alerts you to the possibility of damage to or destruction of equipment if you do not follow the instructions.

Note

 A note calls attention to additional helpful information.

 **Warning**
**EQUIPMENT MISUSE HAZARD**





Equipment misuse can cause the equipment to rupture or malfunction and result in serious injury.

- This equipment is for professional use only.
- Read all instruction manuals, tags, and labels before operating the equipment.
- Use the equipment only for its intended purpose. If you are not sure, call your Graco distributor.
- Do not alter or modify this equipment. Use only genuine Graco parts and accessories.
- Check equipment daily. Repair or replace worn or damaged parts immediately.
- Do not exceed the maximum working pressure of the lowest rated system component. Refer to the **Technical Data** on page 32, 40, or 50 for the maximum working pressure of this equipment.
- Use fluids and solvents which are compatible with the equipment wetted parts. Refer to the **Technical Data** section of all equipment manuals. Read the fluid and solvent manufacturer's warnings.
- Do not use hoses to pull equipment.
- Route hoses away from traffic areas, sharp edges, moving parts, and hot surfaces. Do not expose Graco hoses to temperatures above 82° C (180° F) or below -40° C (-40° F).
- Wear hearing protection when operating this equipment.
- Do not lift pressurized equipment.
- Comply with all applicable local, state, and national fire, electrical, and safety regulations.

**PRESSURIZED EQUIPMENT HAZARD**

Spray, hose leaks, or ruptured components can splash fluid in the eyes or on the skin and cause serious injury.

- Do not stop or deflect leaks with your hand, body, glove, or rag.
- Follow the **Pressure Relief Procedure** on page 11 whenever you are instructed to relieve pressure; stop spraying; clean, check, or repair the equipment.
- Tighten all fluid connections before operating the equipment.
- Check the hoses, tubes, and couplings daily. Replace worn, damaged, or loose parts immediately. Permanently coupled hoses cannot be repaired; replace the entire hose.

 Warning	
	<p>FIRE AND EXPLOSION HAZARD</p> <p>Improper grounding, poor ventilation, open flames or sparks can cause a hazardous condition and result in a fire or explosion and serious injury.</p> <ul style="list-style-type: none"> • Ground the equipment. Refer to Grounding on page page 6. • If there is any static sparking or you feel an electric shock while using this equipment, stop the equipment immediately. Do not use the equipment until you identify and correct the problem. • Provide fresh air ventilation to avoid the buildup of flammable fumes from solvents or the fluid being sprayed. • Keep the work area free of debris, including solvent, rags, and gasoline. • Eliminate all ignition sources such as pilot lights, cigarettes, and static arcs from plastic drop cloths. Do not plug in or unplug power cords or turn lights on or off in the spray area.
	<p>TOXIC FLUID HAZARD</p> <p>Hazardous fluid or toxic fumes can cause serious injury or death if splashed in the eyes or on the skin, inhaled, or swallowed.</p> <ul style="list-style-type: none"> • Know the specific hazards of the fluid you are using. • Store hazardous fluid in an approved container. Dispose of hazardous fluid according to all local, state and national guidelines. • Always wear protective eyewear, gloves, clothing and respirator as recommended by the fluid and solvent manufacturer. • If a diaphragm fails, fluid is exhausted along with the air. When pumping hazardous fluids, place the pump in an appropriate container to catch the fluid if a diaphragm ruptures. • Use fluids and solvents that are compatible with the equipment wetted parts. Refer to the Technical Data section of all equipment manuals.
	<p>BURN HAZARD</p> <p>This equipment may be used with heated fluid, which can cause equipment surfaces to become very hot. To avoid severe burns:</p> <ul style="list-style-type: none"> • Do not touch hot fluid or equipment. • Allow equipment to cool completely before touching it. • Wear gloves if fluid temperature exceeds 110°F (43°C)
	<p>MOVING PARTS HAZARD</p> <p>Moving parts, such as the diaphragm shaft, can pinch or amputate your fingers.</p> <ul style="list-style-type: none"> • Keep clear of all moving parts when starting or operating the pump. • Before servicing the equipment, follow the Pressure Relief Procedure on page page 11 to prevent the equipment from starting unexpectedly.

Installation

General Information

- The Typical Installations shown in Figs. 2-4 are only guides for selecting and installing system components. Contact your Graco distributor for assistance in planning a system to suit your needs.
- Always use Genuine Graco Parts and Accessories.
- Reference numbers and letters in parentheses refer to the callouts in the figures and the parts lists on pages 28-30, 36-38, and 44-48.

CAUTION

The pump is very heavy (see Technical Data on pages 32, 40, and 50 for specific weights). If the pump must be moved, follow the pressure relief procedure on page 11 and have two people to lift the pump by grasping the outlet manifold securely or use appropriate lifting equipment.

WARNING

Read the **TOXIC FLUID HAZARD** warnings on page 5.

Read the **BURN HAZARD** warnings on page 5. To reduce the risk of serious injury due to burns, insulate and/or label the pump before pumping fluids above 110°F (43°C).

Tightening Screws Before First Use

Before using the pump for the first time, check and retorque all external fasteners. See **Torque Sequence**, pages 24-25. After the first day of operation, retorque the fasteners. Although pump use varies, a general guideline is to retorque fasteners every two months.

Grounding

WARNING

Read the **FIRE AND EXPLOSION HAZARD** warnings on page 5

- *Pump:* Connect a ground wire and clamp as shown in Fig. 1. Loosen the grounding screw (W). Insert one end of a 12 ga (1.5 mm²) minimum ground wire (Y) behind the grounding screw and tighten the screw securely. Connect the clamp end of the ground wire to a true earth ground. Order Part No. 222011 Ground Wire and Clamp.

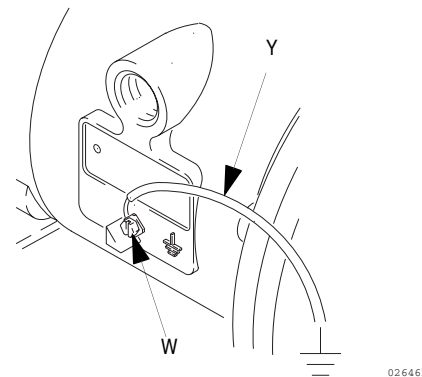

FIG. 1

- *Fluid hoses:* Use only grounded hoses with a maximum of 500 ft. (150 m) combined hose length to ensure grounding continuity.
- *Air compressor:* Follow the manufacturer's recommendations.
- *All solvent pails used when flushing:* Follow the local code. Use only metal pails, which are conductive. Do not place the pail on a non-conductive surface, such as paper or cardboard, which interrupts the grounding continuity.
- *Fluid supply container:* Follow the local code.

Mountings

CAUTION

The pump exhaust air may contain contaminants. Ventilate to a remote area if the contaminants could affect your fluid supply. See **Air Exhaust Ventilation** on page 10.

- Be sure the mounting surface can support the weight of the pump, hoses, and accessories, as well as the stress caused during operation.
- For all mountings, be sure the pump is bolted directly to the mounting surface. Rubber mounting feet are supplied with the pump. They should be used to mount the pump to a cart or to the floor. The rubber mounts have 3/8-16 in. internal and external threads that allow a variety of mounting options. The mounts reduce noise and vibration during operation and provide clearance for the sanitary inlet clamps.
- For ease of operation and service, mount the pump so the air valve cover (2), air inlet, and fluid inlet and outlet ports are easily accessible.

Air Line

WARNING

A bleed-type master air valve (B) is required in the system to relieve air trapped between this valve and the pump. Trapped air can cause the pump to cycle unexpectedly, which could result in serious injury, including splashing in the eyes or on the skin, injury from moving parts, or contamination from hazardous fluids. See FIG. 2.

1. Install the air line accessories as shown in FIG. 2. Mount these accessories on the wall or on a bracket. Be sure the air line supplying the accessories is grounded.
 - a. Install an air regulator (C) and gauge to control the fluid pressure. The fluid outlet pressure will be the same as the setting of the air regulator.
 - b. Locate one bleed-type master air valve (B) close to the pump and use it to relieve trapped air. See the **WARNING** above. Locate the other master air valve (E) upstream from all air line

accessories and use it to isolate them during cleaning and repair.

- c. The air line filter (F) removes harmful dirt and moisture from the compressed air supply.

2. Install a grounded, flexible air hose (A) between the accessories and the 1/2 npt(f) pump air inlet (N). See Fig. 5. Use a minimum 3/8 in. (9.5 mm) ID air hose. Screw an air line quick disconnect coupler (D) onto the end of the air hose (A), and screw the mating fitting into the pump air inlet snugly. Do not connect the coupler (D) to the fitting until you are ready to operate the pump.

Installation of Remote Pilot Air Lines

1. Refer to Parts Drawings. Connect air line to pump as in preceding steps.
2. Connect 1/4 in. O.D. tubing to push type connectors (14) on air motor of pump.



By replacing the push type connectors, other sizes or types of fittings may be used. The new fittings will require 1/8 in. npt threads.

3. Connect remaining ends of tubes to external air signal, such as Graco's Cycleflo (P/N 195264) or Cycleflo II (P/N195265) controllers.



The air pressure at the connectors must be at least 30% of the air pressure to the air motor for the pump to operate.

Fluid Suction Line

1. Use flexible, grounded fluid hoses.
2. For best sealing results, use a standard Tri-Clamp® style sanitary gasket of a flexible material such as Buna-N, fluoroelastomer, or silicon.
3. If the fluid inlet pressure to the pump is more than 25% of the outlet working pressure, the ball check valves will not close fast enough, resulting in inefficient pump operation.
4. At inlet fluid pressures greater than 15 psi (0.1 MPa, 1 bar), diaphragm life will be shortened.
5. See the **Technical Data** on pages 32, 40, and 50 for maximum suction lift (wet and dry).

Fluid Outlet Line

WARNING



A fluid drain valve (J) is required to relieve pressure in the hose if it is plugged. The drain valve reduces the risk of serious injury, including splashing in the eyes or on the skin, or contamination from hazardous fluids when relieving pressure. Install the valve close to the pump fluid outlet. See FIG. 2.

1. Use flexible grounded fluid hoses (L).
2. For best sealing results, use a standard Tri-Clamp® style sanitary gasket of a flexible material such as Buna-N, fluoroelastomer, or silicon
3. Install a fluid drain valve (J) near the fluid outlet. See the **WARNING** above, and FIG. 2.
4. Install a shutoff valve (K) in the fluid outlet line.

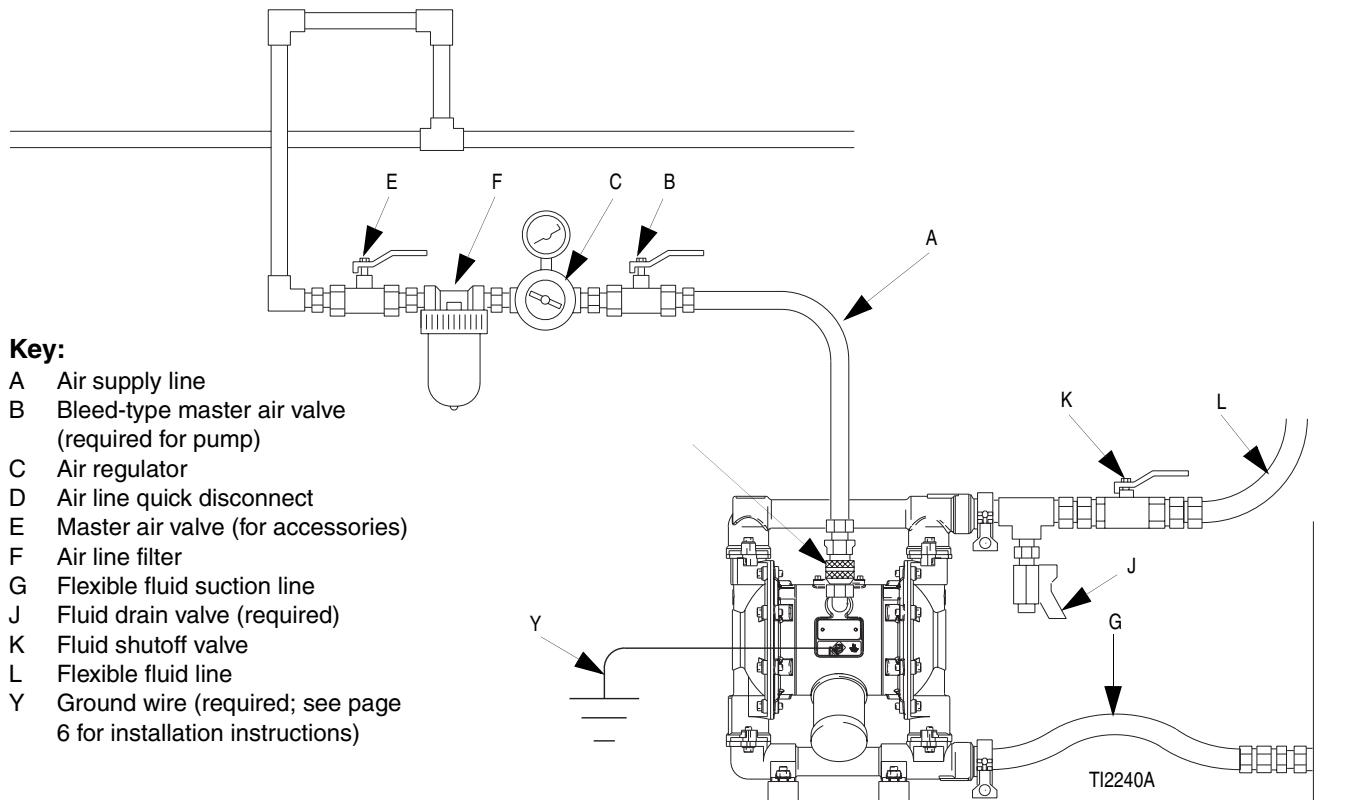

FIG. 2 Typical Floor-Mount Installation

Changing the Orientation of the Fluid Inlet and Outlet Ports

The pump is shipped with the ports facing the same direction. To reverse the orientation of the ports:

1. Remove the screws and nuts holding the inlet and/or outlet manifold to the covers.
2. Reverse the manifold and reattach. Install the screws and torque to 120-150 in-lb (14-17 N•m) on 1040 and 1590 pump models. Torque to 190-220 in-lb (22-25 N•m) on 2150 pump models. See **Torque Sequence**, pages 24-25.

Key:

- N 1/2 npt(f) air inlet port
- P Muffler (air exhaust port is 3/4 npt(f))
- R Fluid inlet port
- S Fluid outlet port
- 106 Manifold and cover screws
- 3 Air valve screws

 Torque to 50-60 in-lb (5.6-6.8 N•m)

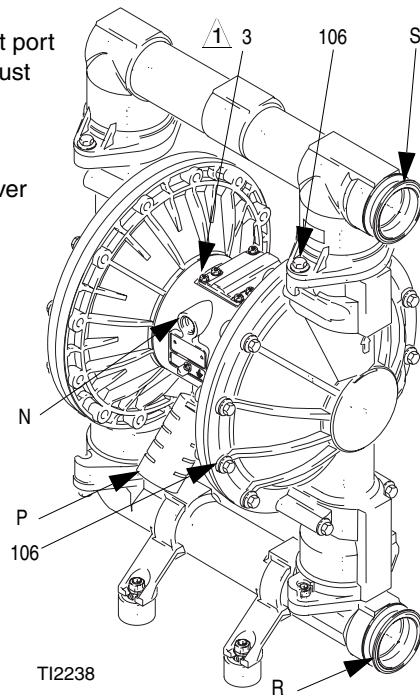



FIG. 3

Air Exhaust Ventilation

WARNING



Read the **FIRE AND EXPLOSION HAZARD** and **TOXIC FLUID HAZARD** warnings on page 5 before operating this pump.

Be sure the system is properly ventilated for your type of installation. You must vent the exhaust to a safe place, away from people, animals, food handling areas, and all sources of ignition when pumping flammable or hazardous fluids.

Diaphragm failure will cause the fluid being pumped to exhaust with the air. Place an appropriate container at the end of the air exhaust line to catch the fluid. See FIG. 4.

The air exhaust port is 3/4 npt(f). Do not restrict the air exhaust port. Excessive exhaust restriction can cause erratic pump operation.

If the muffler (P) is installed directly to the air exhaust port, apply PTFE thread tape or anti-seize thread lubricant to the muffler threads before assembly.

To provide a remote exhaust:

1. Remove the muffler (P) from the pump air exhaust port.
2. Install a grounded air exhaust hose (T) and connect the muffler (P) to the other end of the hose. The minimum size for the air exhaust hose is 3/4 in. (19 mm) ID. If a hose longer than 15 ft (4.57 m) is required, use a larger diameter hose. Avoid sharp bends or kinks in the hose.
3. Place a container (U) at the end of the air exhaust line to catch fluid in case a diaphragm ruptures. See FIG. 4.

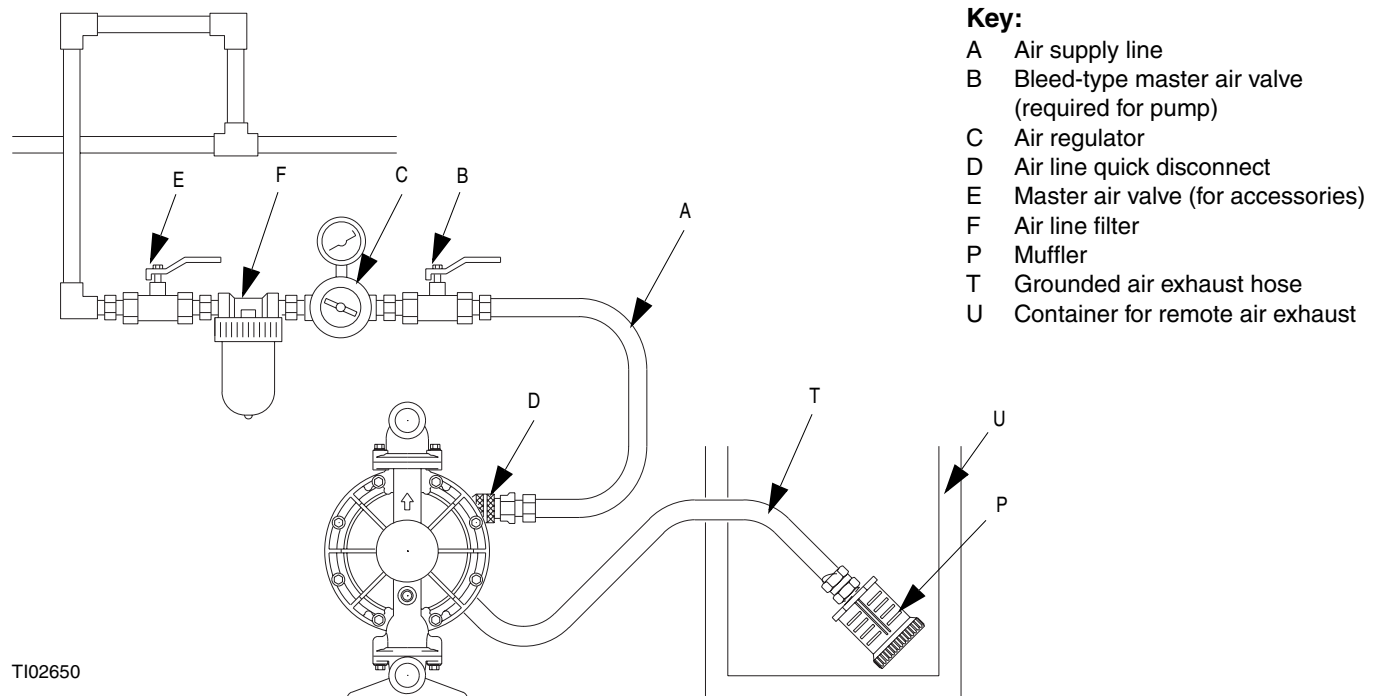

T102650

FIG. 4 Venting Exhaust Air

Operation

Pressure Relief Procedure

WARNING



Read the **PRESSURIZED EQUIPMENT HAZARD** warnings on page 4.

The equipment stays pressurized until pressure is manually relieved. To reduce the risk of serious injury from pressurized fluid or splashing fluid, follow this procedure whenever you:

- are instructed to relieve pressure
- stop pumping
- check, clean or service any system equipment

1. Shut off the air to the pump.
2. Open the dispensing valve, if used.
3. Open the fluid drain valve to relieve fluid pressure, having a container ready to catch the drainage.

Sanitize the Pump Before First Use

It is the user's responsibility to properly sanitize the pump before using. This may include disassembly and inspection of the wetted components. The pump was tested in an NSF registered lubricant with incidental food contact rating (H1). Remove compound by wiping or washing, leaving surfaces free of any substance that could be transferred to food being processed. Flush the pump thoroughly with a compatible cleaning solution or disassemble and inspect. Follow the steps under **Starting and Adjusting the Pump** or the Service section.

WARNING



Read the **TOXIC FLUID HAZARD** warnings on page 5

Never move or lift a pump under pressure. If dropped, the fluid section may rupture. Always follow the **Pressure Relief Procedure** before lifting the pump.

Starting and Adjusting the Pump

1. Be sure the pump is properly grounded. Refer to **Grounding** on page 4.
2. Check fittings to be sure they are tight. Use a compatible liquid thread sealant on male threads. Tighten fluid inlet and outlet fittings securely.
3. Place the suction tube (if used) in fluid to be pumped.



If fluid inlet pressure to the pump is more than 25% of outlet working pressure, the ball check valves will not close fast enough, resulting in inefficient pump operation.

4. Place the end of fluid hose (L) into an appropriate container.
5. Close the fluid drain valve (J).
6. Back out the air regulator (C) knob, and open all bleed-type master air valves (B, E).
7. If the fluid hose has a dispensing device, hold it open while continuing with the following step.
8. Slowly increase air pressure with the air regulator (C) until the pump starts to cycle. Allow the pump to cycle slowly until all air is pushed out of the lines and the pump is primed.

When you are flushing, run the pump long enough to thoroughly clean the pump and hoses. Close the air regulator. Remove the suction tube from the cleaning solution and place it in the fluid to be pumped.

Operation of Remote Piloted Pumps

1. Follow preceding steps 1 through 7 of **Starting and Adjusting Pump**.
2. Open air regulator (C).

WARNING

The pump may cycle once before the external signal is applied. Injury is possible. If pump cycles, wait until end before proceeding.

3. Pump will operate when air pressure is alternately applied and relieved to push type connectors (14).



Leaving air pressure applied to the air motor for extended periods when the pump is not running may shorten the diaphragm life. Using a 3-way solenoid valve to automatically relieve the pressure on the air motor when the metering cycle is complete prevents this from occurring.

Pump Shutdown

WARNING



To reduce the risk of serious injury, whenever you are instructed to relieve pressure, always follow the **Pressure Relief Procedure**

Maintenance

Lubrication

The air valve is designed to operate unlubricated, however if lubrication is desired, every 500 hours of operation (or monthly) remove the hose from the pump air inlet and add two drops of machine oil to the air inlet.

CAUTION

Do not over-lubricate the pump. Oil is exhausted through the muffler and could contaminate your fluid supply or other equipment. Excessive lubrication can also cause the pump to malfunction.

Flushing

WARNING



To reduce the risk of serious injury, whenever you are instructed to relieve pressure, always follow the **Pressure Relief Procedure** on page 11.

Flush the pump often enough to prevent the fluid you are pumping from drying or freezing in the pump and damaging it. Use a compatible cleaning solution.

Always flush the pump and relieve the pressure before storing it for any length of time.

Tightening Threaded Connections

Before each use, check all hoses for wear or damage, and replace as necessary. Check to be sure all threaded connections are tight and leak-free. Check fasteners. Tighten or retorque as necessary. Although pump use varies, a general guideline is to retorque fasteners every two months. See **Torque Sequence**, page 24-25.

Preventive Maintenance Schedule

Establish a preventive maintenance schedule, based on the pump's service history. This is especially important for prevention of spills or leakage due to diaphragm failure.

Troubleshooting

WARNING

To reduce the risk of serious injury, whenever you are instructed to relieve pressure, always follow the **Pressure Relief Procedure** on page 11.

- Relieve the pressure before checking or servicing the equipment.
- Check all possible problems and causes before disassembling the pump.

PROBLEM	CAUSE	SOLUTION
Pump cycles at stall or fails to hold pressure at stall.	Worn check valve balls (301), seats (201) or o-rings (202).	Replace. See page 18.
Pump will not cycle, or cycles once and stops.	Air valve is stuck or dirty.	Disassemble and clean air valve. See page 16. Use filtered air.
	Check valve ball (301) severely worn and wedged in seat (201) or manifold (102 or 103).	Replace ball and seat. See page 18.
	Check valve ball (301) is wedged into seat (201), due to overpressurization.	Install Pressure Relief Valve (see page 10).
	Dispensing valve clogged.	Relieve pressure and clear valve.
Pump operates erratically.	Clogged suction line.	Inspect; clear.
	Sticky or leaking balls (301).	Clean or replace. See page 18.
	Diaphragm ruptured.	Replace. See pages 19-21.
	Restricted exhaust.	Remove restriction.
Air bubbles in fluid.	Suction line is loose.	Tighten.
	Diaphragm ruptured.	Replace. See pages 19-21.
	Loose inlet manifold (102), damaged seal between manifold and seat (201), damaged o-rings (202).	Tighten manifold bolts (106) or replace seats (201) or o-rings (202). See page 18.
	Loose diaphragm shaft bolt (107).	Tighten or replace (pages 19-21).
	Damaged o-ring (108).	Replace. See pages 19-21.

PROBLEM	CAUSE	SOLUTION
Leak in inlet or outlet sanitary fitting.	Loose sanitary clamp.	Tighten clamp.
	Damaged or worn gasket.	Replace gasket
	Misalignment of inlet/outlet hose or pipe.	Use flexible hoses at pump inlet and outlet
	Gasket does not seal.	Use a standard sanitary gasket of flexible material such as Buna-N, fluoroelastomer, or silicon.
Fluid in exhaust air.	Diaphragm ruptured.	Replace. See pages 19-21.
	Loose diaphragm shaft bolt (107).	Tighten or replace (pages 19-21).
	Damaged o-ring (108).	Replace. See pages 19-21.
Pump exhausts excessive air at stall.	Worn air valve block (7†◆), o-ring (6†◆), plate (8◆), pilot block (18†◆), u-cups (10†◆), or pilot pin o-rings (17†◆).	Repair or replace. See page 16.
	Worn shaft seals (402).	Replace. See pages 19-21.
Pump leaks air externally.	Air valve cover (2) or air valve cover screws (3) are loose.	Tighten screws. See page 16.
	Air valve gasket (4†◆) or air cover gasket (22) is damaged.	Inspect; replace. See pages 16, 22-23.
	Air cover screws (25) are loose.	Tighten screws. See pages 22-23.
Pump leaks fluid externally from ball check valves.	Loose manifolds (102, 103), damaged seal between manifold and seat (201), damaged o-rings (202).	Tighten manifold bolts (106) or replace seats (201) or o-rings (202). See page 18.

Service

Repairing the Air Valve

Tool Required

- Torque wrench
- Torx (T20) screwdriver or 7 mm (9/32 in.) socket wrench
- Needle-nose pliers
- O-ring pick
- Lithium base grease



Air Valve Repair Kits 236273 (aluminum) and 255061 (sst) are available. Refer to the Repair Kit Matrix parts section for the appropriate pump size. Parts included in the kit are marked with a symbol, for example (4†). Use all the parts in the kit for the best results.

Disassembly

WARNING

To reduce the risk of serious injury, whenever you are instructed to relieve pressure, always follow the **Pressure Relief Procedure** on page 11.

1. Relieve the pressure.
2. With a Torx (T20) screwdriver or 7 mm (9/32 in.) socket wrench, remove the six screws (3), air valve cover (2), and gasket (4†◆). See FIG. 5.
3. Move the valve carriage (5) to the center position and pull it out of the cavity. Remove the valve block (7†◆) and o-ring (6†◆) from the carriage. Using a needle-nose pliers, pull the pilot block (18†◆) straight up and out of the cavity. See FIG. 6.
4. Pull the two actuator pistons (11) out of the bearings (12). Remove the u-cup packings (10†◆) from the pistons. Pull the pilot pins (16) out of the bearings (15). Remove the o-rings (17†◆) from the push pins. See FIG. 7.
5. Inspect the valve plate (8◆) in place. If damaged, use a Torx (T20) screwdriver or 7 mm (9/32 in.) socket wrench to remove the three screws (3). Remove the valve plate (8◆) and, on aluminum center housing models, remove the seal (9†). See FIG. 8.
6. Inspect the bearings (12, 15) in place. See FIG. 7. The bearings are tapered and, if damaged, must be removed from the outside. This requires disassembly of the fluid section. See page 22.
7. Clean all parts and inspect for wear or damage. Replace as needed. Reassemble.

Reassembly

1. If you replaced the bearings (12, 15), reinstall as explained on page 22. Reassemble the fluid section.
2. On aluminum center housing models, install the valve plate seal (9†) into the groove at the bottom of the valve cavity. The rounded side of the seal **must face down** into the groove. See FIG. 8.
3. Install the valve plate (8◆) in the cavity. On aluminum center housing models, the plate is reversible, so either side can face up. Install the three screws (3), using a Torx (T20) screwdriver or 7 mm (9/32 in.) socket wrench. Tighten until the screws bottom out on the housing. See FIG. 8.
4. Install an o-ring (17†◆) on each pilot pin (16). Grease the pins and o-rings. Insert the pins into the bearings (15), **narrow** end first. See FIG. 7.
5. Install a u-cup packing (10†◆) on each actuator piston (11), so the lips of the packings face the **narrow** end of the pistons. See FIG. 7.
6. Lubricate the u-cup packings (10†◆) and actuator pistons (11). Insert the actuator pistons in the bearings (12), **wide** end first. Leave the narrow end of the pistons exposed. See FIG. 7.
7. Grease the lower face of the pilot block (18†◆) and install so its tabs snap into the grooves on the ends of the pilot pins (16). See FIG. 6.
8. Grease the o-ring (6†◆) and install it in the valve block (7†◆). Push the block onto the valve carriage (5). Grease the lower face of the valve block. See FIG. 6.
9. Install the valve carriage (5) so its tabs slip into the grooves on the narrow end of the actuator pistons (11). See FIG. 6.
10. Align the valve gasket (4†◆) and cover (2) with the six holes in the center housing (1). Secure with six screws (3), using a Torx (T20) screwdriver or 7 mm (9/32 in.) socket wrench. Torque to 50-60 in-lb (5.6-6.8 N•m). See FIG. 5.

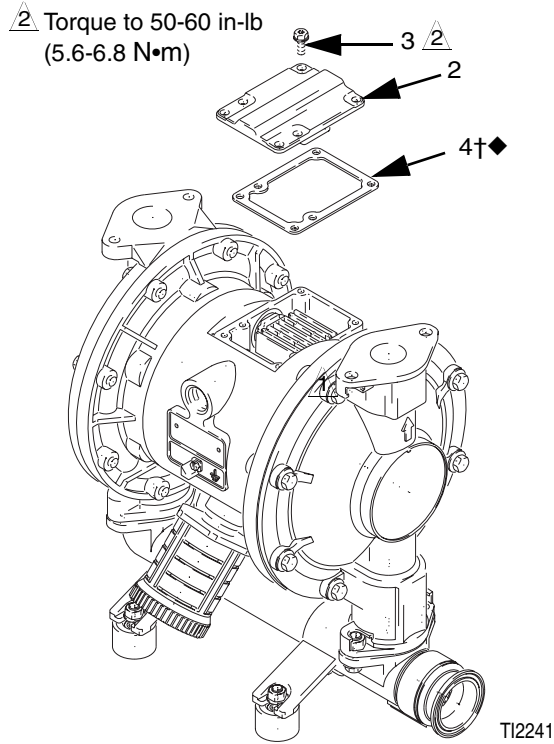

FIG. 5

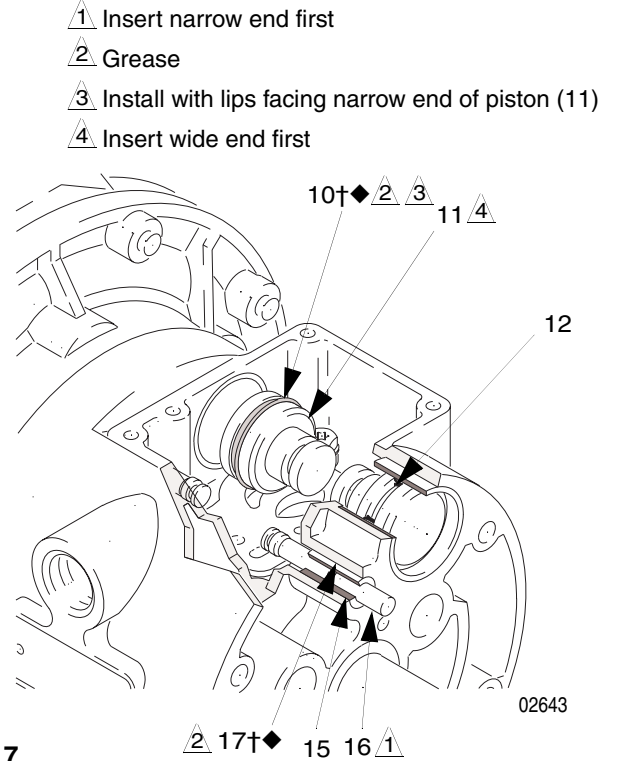

FIG. 7

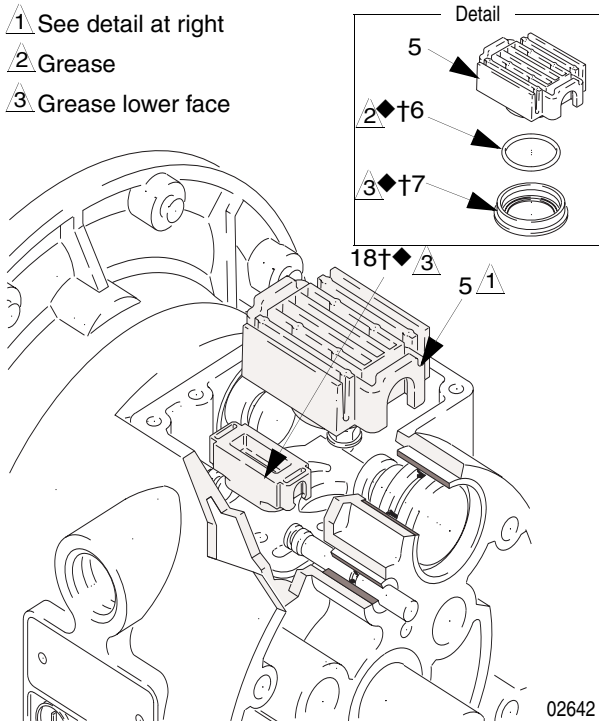

FIG. 6

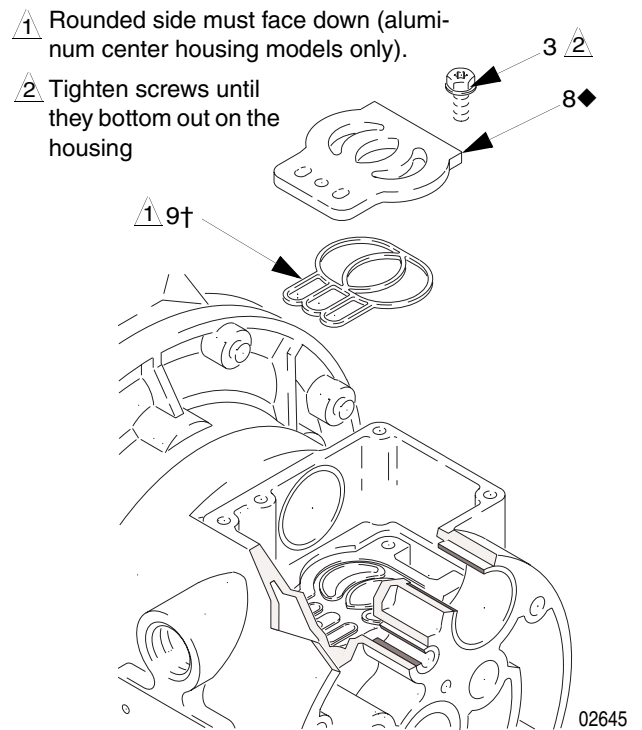

FIG. 8

Ball Check Valve Repair

Tools Required

- Torque wrench
- 10 mm for 1040 pump or 13 mm socket wrench for 1590 and 2150 pumps.
- O-ring pick

Disassembly

- A Fluid Section Repair Kit is available. Refer to the Repair Kit Matrix parts section for the appropriate pump size. to order the correct kit for your pump. Parts included in the kit are marked with an asterisk, for example (201*). Use all the parts in the kit for the best results.
- To ensure proper seating of the balls (301), always replace the seats (201) when replacing the balls. Also, on some models, replace the o-rings (202).

WARNING
To reduce the risk of serious injury, whenever you are instructed to relieve pressure, always follow the **Pressure Relief Procedure** on page 11.

1. Relieve the pressure. Disconnect all hoses.
2. Remove the pump from its mounting.
3. Using a 10 mm or 13 mm socket wrench, remove the four bolts (106) and nuts holding the outlet manifold (103) to the fluid covers (101). See FIG. 9.
4. Remove the o-rings (202, *not used on some models*), seats (201), and balls (301) from the manifold (103).
5. Turn the pump over and remove the inlet manifold (102). Remove the o-rings (202, *not used on some models*), seats (201), and balls (301) from the fluid covers (101).

Reassembly

1. Clean all parts and inspect for wear or damage. Replace parts as needed.
2. Reassemble in the reverse order, following all notes in FIG. 9. Be sure the ball checks and manifolds are assembled **exactly** as shown. The arrows (A) on the fluid covers (101) **must** point toward the outlet manifold (103).

- 1 Apply medium-strength (blue) Loctite® or equivalent to threads, and torque to 120-150 in-lb (14-17 N•m) on 1040 and 1590 pump models. Torque to 190-220 in-lb (22-25 N•m) on 2150 pump models. See Torque Sequence, page 24-26.
- 2 Arrow (A) must point toward outlet manifold (103)
- 3 Beveled seating surface must face the ball (301)
- 4 Not used on some models

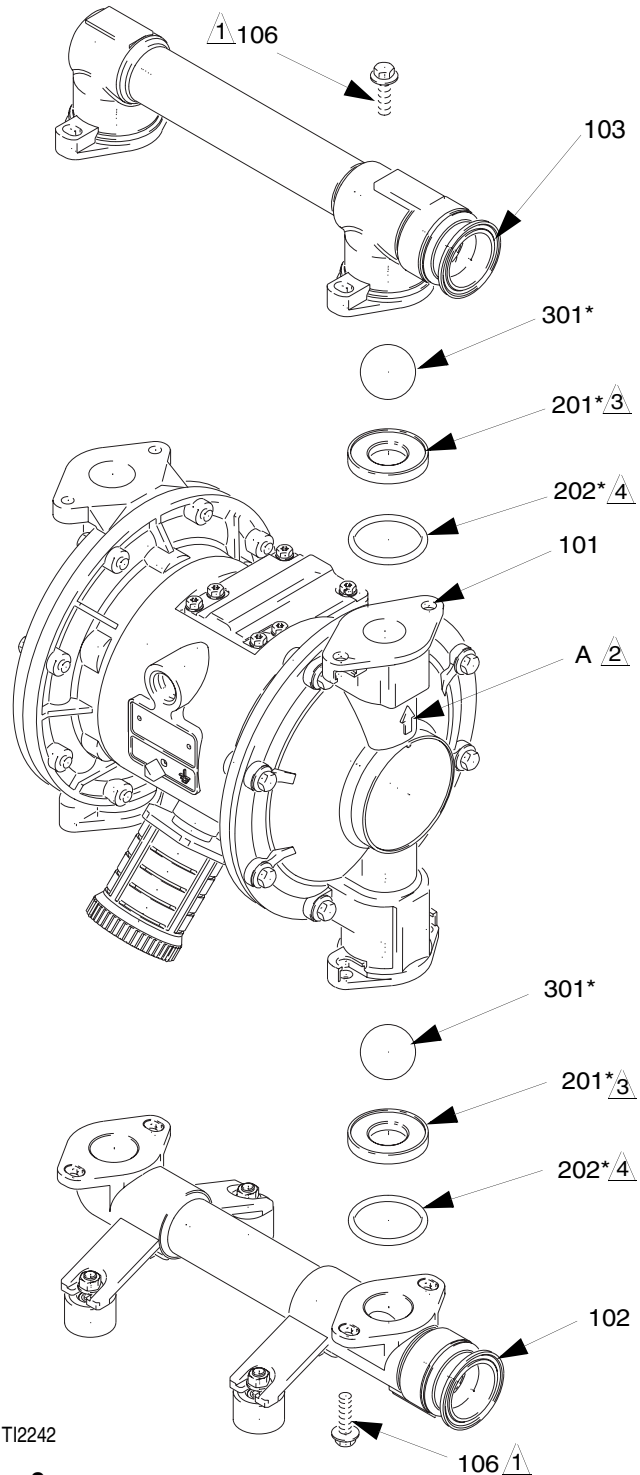

T12242

FIG. 9

Diaphragm Repair

Tools Required

- Torque wrench
- 10 mm for 1040 pump or 13 mm socket wrench for 1590 and 2150 pumps.
- 15 mm socket wrench
- 19 mm open end wrench
- O-ring pick
- Lithium-base grease

Disassembly

 A Fluid Section Repair Kit is available. Refer to page 27, 35, or 43 to order the correct kit for your pump. Parts included in the kit are marked with an asterisk, for example (401*). Use all the parts in the kit for the best results.

WARNING

To reduce the risk of serious injury, whenever you are instructed to relieve pressure, always follow the **Pressure Relief Procedure** on page 11.

1. Relieve the pressure.
2. Remove the manifolds and disassemble the ball check valves as explained on 18.
3. Using a 10 mm or 13 mm socket wrench, remove the screws (106) holding the fluid covers (101) to the air covers (23). Pull the fluid covers (101) off the pump. See FIG. 10.
4. Loosen but do not remove the diaphragm shaft bolts (107), using a 15 mm socket wrench on both bolts.

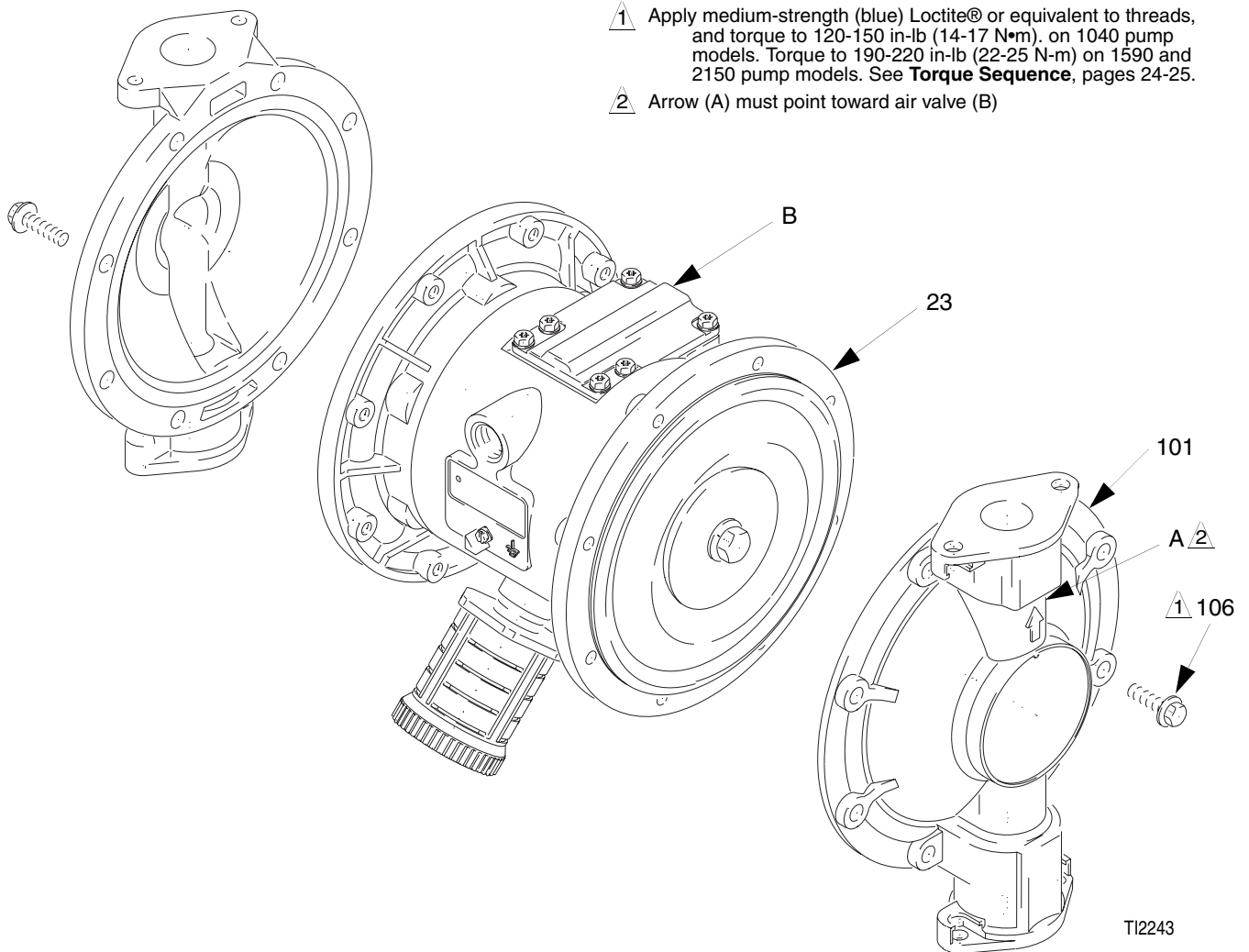

FIG. 10

Service

5. Unscrew one bolt from the diaphragm shaft (24) and remove the o-ring (108), fluid side diaphragm plate (105), PTFE diaphragm (403, *used on PTFE models only*), diaphragm (401), and air side diaphragm plate (104). See FIG. 11.
 6. Pull the other diaphragm assembly and the diaphragm shaft (24) out of the center housing (1). Hold the shaft flats with a 19 mm open end wrench, and remove the bolt (107) from the shaft. Disassemble the remaining diaphragm assembly.
 7. Inspect the diaphragm shaft (24) for wear or scratches. If it is damaged, inspect the bearings (19) in place. If the bearings are damaged, refer to page 22.
 8. Reach into the center housing (1) with an o-ring pick and hook the u-cup packings (402), then pull them out of the housing. This can be done with the bearings (19) in place.
 9. Clean all parts and inspect for wear or damage. Replace parts as needed.
- c. *On PTFE models only*, install the PTFE diaphragm (403*). Make certain the side marked AIR SIDE faces the center housing (1).
 - d. Install the diaphragm (401*) on the bolt. Make certain the side marked AIR SIDE faces the center housing (1).
 - e. Install the air side diaphragm plate (104) so the rounded side faces the diaphragm (401). This plate is used on all models, and is stamped with its part number.
 - f. Apply medium-strength (blue) Loctite® or equivalent to the bolt (107) threads. Screw the bolt into the shaft (24) hand tight.

3. Grease the length and ends of the diaphragm shaft (24), and slide it through the housing (1).
4. Assemble the other diaphragm assembly to the shaft as explained in step 2.
5. Hold one shaft bolt (107) with a wrench and torque the other bolt to 20-25 ft-lb (27-34 N•m) at 100 rpm maximum.
6. Align the fluid covers (101) and the center housing (1) so the arrows (A) on the covers face the same direction as the air valve (B). Secure the covers with the screws handtight. See Fig. 13. Using a 10 mm or 13 mm socket wrench, torque the screws oppositely and evenly to 120-150 in-lb (14-17 N•m) 1040 pump models and 190-220 in-lb (22-25 N•m) on 1590 and 2150 pump models. See **Torque Sequence**, pages 24-25.
7. Reassemble the ball check valves and manifolds as explained on page 18

Reassembly

1. Install the shaft u-cup packings (402*) so the lips face **out** of the housing (1). Lubricate the packings. See FIG. 11.
2. Install the diaphragm assembly on one end of the shaft (24) as follows:
 - a. Install the o-ring (108*) on the shaft bolt (107).
 - b. Install the fluid side diaphragm plate (105) on the bolt so the rounded side faces the diaphragm (401).



The fluid side diaphragm plate (105) is stainless steel. This plate **is not** stamped with its part number. Be sure to install this plate on the fluid side of the diaphragm.

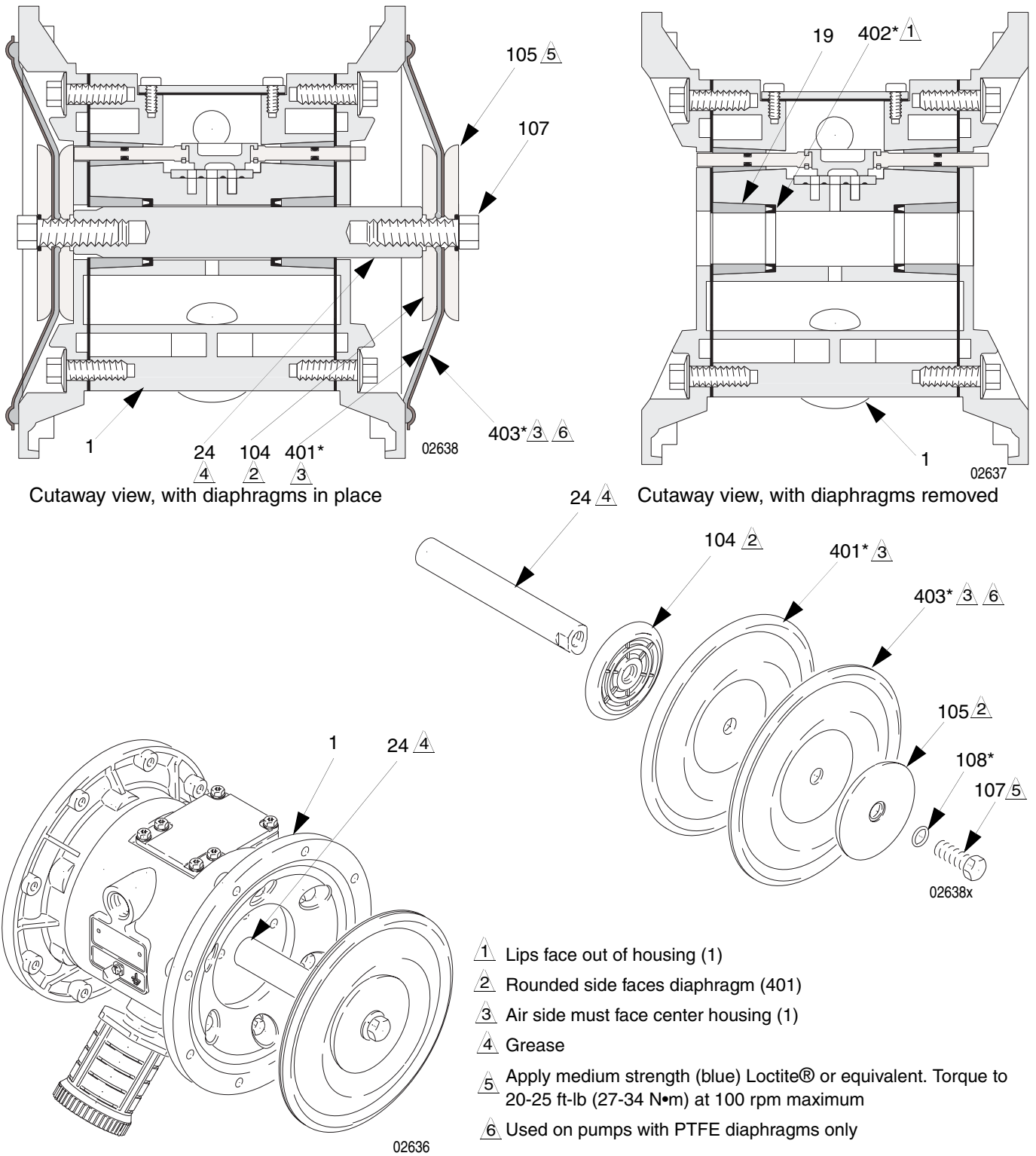

FIG. 11

Bearing and Air Gasket Removal

Tools Required

- Torque wrench
- 10 mm socket wrench
- Bearing puller
- O-ring pick
- Press, or block and mallet

Disassembly



Do not remove undamaged bearings.



WARNING

To reduce the risk of serious injury, whenever you are instructed to relieve pressure, always follow the **Pressure Relief Procedure** on page 11.

1. Relieve the pressure.
2. Remove the manifolds and disassemble the ball check valves as explained on page 18.
3. Remove the fluid covers and diaphragm assemblies as explained on page 19.



If you are removing only the diaphragm shaft bearing (19), skip step 4.

4. Disassemble the air valve as explained on page 16.
5. Using a 10 mm socket wrench, remove the screws (25) holding the air covers (23) to the center housing (1). See FIG. 12.
6. Remove the air cover gaskets (22). Always replace the gaskets with new ones.

7. Use a bearing puller to remove the diaphragm shaft bearings (19), air valve bearings (12) or pilot pin bearings (15). Do not remove undamaged bearings.
8. If you removed the diaphragm shaft bearings (19) reach into the center housing (1) with an o-ring pick and hook the u-cup packings (402), then pull them out of the housing. Inspect the packings. See FIG. 11.

Reassembly

1. If removed, install the shaft u-cup packings (402*) so the lips face **out** of the housing (1).
2. The bearings (12, 15, and 19) are tapered and can only be installed one way. Insert the bearings into the center housing (1), **tapered end first**. Using a press or a block and rubber mallet, press-fit the bearing so it is flush with the surface of the center housing.
3. Reassemble the air valve as explained on page 16.
4. Align the new air cover gasket (22) so the pilot pin (16) protruding from the center housing (1) fits through the proper hole (H) in the gasket.
5. Align the air cover (23) so the pilot pin (16) fits in the middle hole (M) of the three small holes near the center of the cover. Install the screws (25), handtight. Apply medium-strength (blue) Loctite® or equivalent to the threads of the screws (25). See FIG. 12. Using a 10 mm socket wrench, torque the screws oppositely and evenly to 130-150 in-lb (15-17 N•m).
6. Install the diaphragm assemblies and fluid covers as explained on page 19.
7. Reassemble the ball check valves and manifolds as explained on page 18.

- 1 Insert bearings tapered end first
- 2 Press-fit bearings flush with surface of center housing (1)
- 3 Apply medium strength (blue) Loctite® or equivalent. Torque to 130-150 in-lb (15-17 N•m)

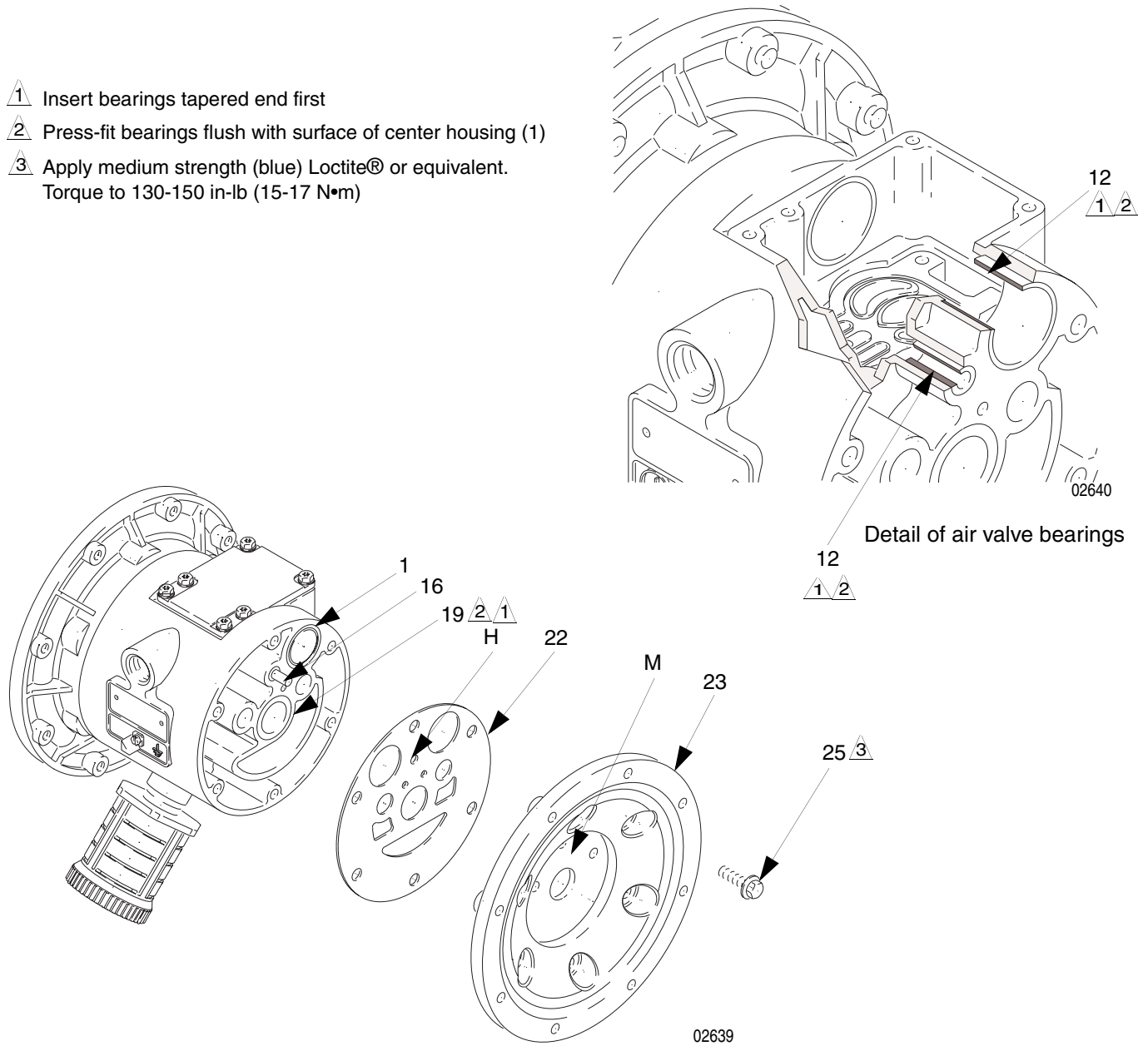

FIG. 12

Torque Sequence

1040

Pump Model Numbers D7S____, D8S____, DRS____ and DSS____

Always follow torque sequence when instructed to torque fasteners.

1. Left/Right Fluid Covers
Torque bolts to 120-150 in-lb (14-17 N•m)

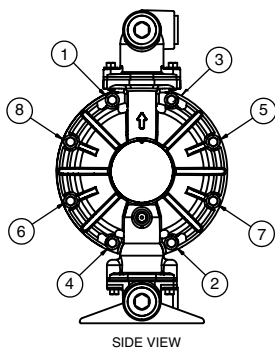

2. Inlet Manifold
Torque bolts to 120-150 in-lb (14-17 N•m)

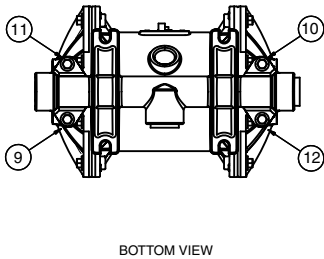

3. Outlet Manifold
Torque bolts to 120-150 in-lb (14-17 N•m)

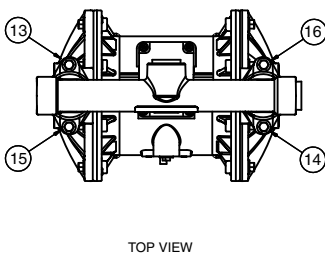

1590

Pump Model Numbers DBS____, DCS____, DTS____, and DUS____

Always follow torque sequence when instructed to torque fasteners.

1. Left/Right Fluid Covers
Torque bolts to 190-220 in-lb (22-25 N•m)

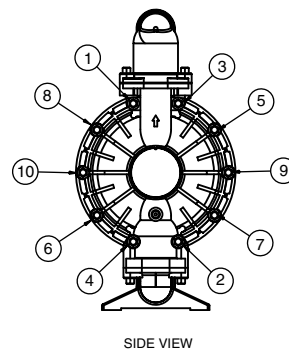

2. Inlet Manifold
Torque bolts to 120-150 in-lb (14-17 N•m)

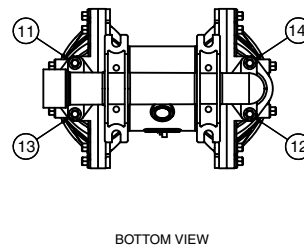

3. Outlet Manifold
Torque bolts to 120-150 in-lb (14-17 N•m)

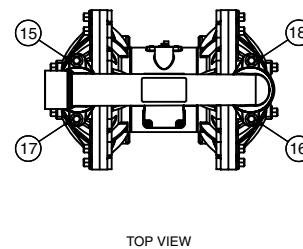

2150

Pump Model Numbers DFS____, DGS____, DVS____, and DWS____

Always follow torque sequence when instructed to torque fasteners.

1. Left/Right Fluid Covers
Torque bolts to 190-220 in-lb (22-25 N•m)

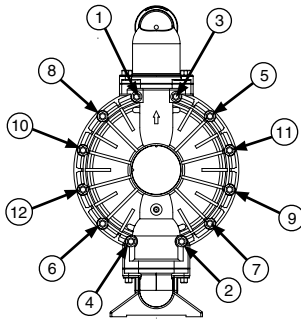

SIDE VIEW

2. Inlet Manifold
Torque bolts to 190-220 in-lb (22-25 N•m)

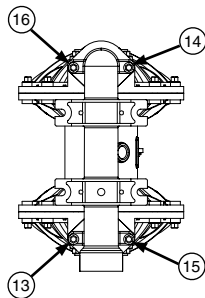

BOTTOM VIEW

3. Outlet Manifold
Torque bolts to 190-220 in-lb (22-25 N•m)

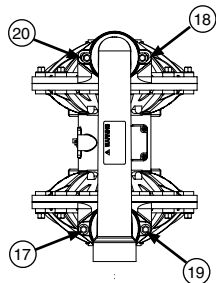

TOP VIEW

Pump Matrix - 1040

Husky 1040 Aluminum and Stainless Steel Sanitary Pumps

Your Model No. is marked on the pump's serial plate. To determine the Model No. of your pump from the following matrix, select the six digits which describe your pump, working from left to right. The first digit is always **D**, designating Husky diaphragm pumps. The remaining

five digits define the materials of construction. For example, a pump with an aluminum air motor, stainless steel fluid section, stainless steel seats, PTFE balls, and PTFE diaphragms is Model **D 7 SB1 1**. To order replacement parts, refer to the part lists on pages 29-30. *The digits in the matrix **do not** correspond to the ref. nos. in the parts drawing and lists.*

Diaphragm Pump	1040 Air Motor	Fluid Section	-	Seats	Balls	Diaphragms
D (for all pumps)	7 Aluminum (Standard)	S Sanitary Stainless Steel	-	3 (316 SST with PTFE o-rings)	1 (PTFE)	1 (PTFE)
	8 Aluminum (Remote)		-	B (316 SST with FDA fluoroelastomer o-rings)	6 (Santoprene®)	6 (Santoprene®)
	R Stainless Steel (Standard)		-	6 (Santoprene® with PTFE o-rings)	7 (Buna-N)	7 (Buna-N)
	S Stainless Steel (Remote)		-	C (Santoprene® with FDA fluoroelastomer o-rings)	8 (fluoroelastomer)	8 (fluoroelastomer)
			-	7 (Buna-N)		
			-	8 (fluoroelastomer)		

Repair Kit Matrix - 1040

For Husky 1040 Stainless Steel Sanitary Pumps

Repair Kits may be ordered separately. To repair the air valve, order **Part No. 236273** for aluminum center housing models or **Part No. 255061** for stainless steel center housing models (see page 28). Parts included in the Air Valve Repair Kit are marked with a symbol in the parts list, for example (4†◆).

To repair your pump, select the six digits which describe your pump from the following matrix, working from left to right. The first digit is always **D**, the second digit is

always **0** (zero), and the third is always **7**. The remaining three digits define the materials of construction. Parts included in the kit are marked with an asterisk in the parts list, for example (201*). For example, if your pump has stainless steel seats, PTFE balls, and PTFE diaphragms, order Repair Kit **D 0 7 B 1 1**. If you only need to repair certain parts (for example, the diaphragms), use the 0 (null) digits for the seats and balls, and order Repair Kit **D 0 7 0 0 1**. *The digits in the matrix **do not** correspond to the ref. nos. in the parts drawing and lists on pages 27-28.*

Diaphragm Pump	Null	Pump Size	-	Seats	Balls	Diaphragms	
D (for all pumps)	0 (for all pumps)	7 1040	-	0 (null)	0 (null)	0 (null)	
				-	3 (316 SST with PTFE o-rings)	1 (PTFE) white	1 (PTFE) white
				-	B (316 SST with FDA fluoroelastomer o-rings)	6 (Santoprene®) blue	6 (Santoprene®) blue
				-	6 (Santoprene® with PTFE o-rings)	7 (Buna-N) black	7 (Buna-N) black
				-	C (Santoprene® with FDA fluoroelastomer o-rings)	8 (fluoroelastomer) green	8 (fluoroelastomer) black
				-	7 (Buna-N) black		
				-	8 (fluoroelastomer) green		

Parts - 1040

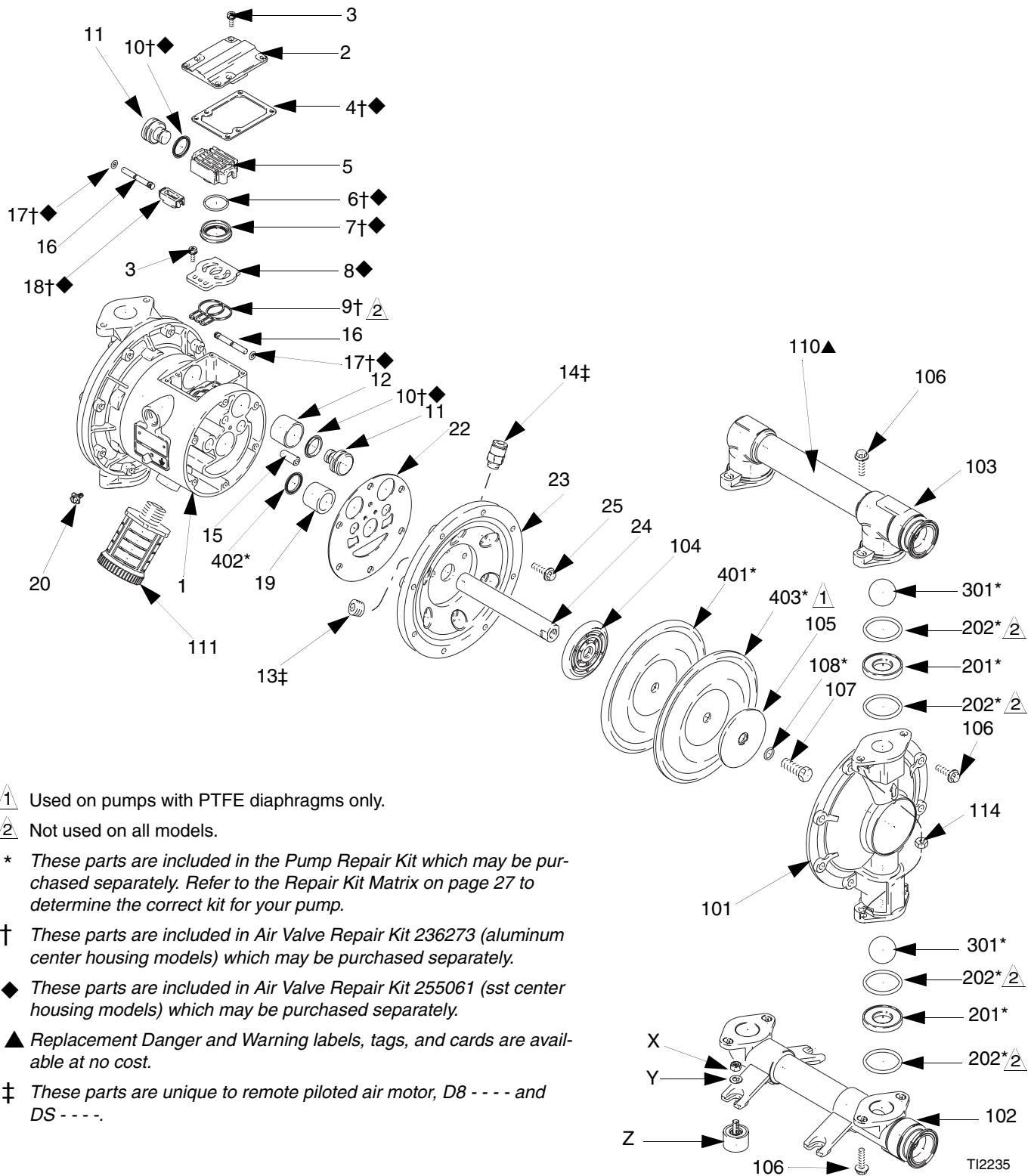

▲ Used on pumps with PTFE diaphragms only.

◻ Not used on all models.

* These parts are included in the Pump Repair Kit which may be purchased separately. Refer to the Repair Kit Matrix on page 27 to determine the correct kit for your pump.

† These parts are included in Air Valve Repair Kit 236273 (aluminum center housing models) which may be purchased separately.

◆ These parts are included in Air Valve Repair Kit 255061 (sst center housing models) which may be purchased separately.

▲ Replacement Danger and Warning labels, tags, and cards are available at no cost.

‡ These parts are unique to remote piloted air motor, D8 - - - - and DS - - - -.

Air Motor Parts List (Matrix Column 2)

Digit	Ref. No.	Part No.	Description	Qty
7	1	188838	HOUSING, center; aluminum	1
	2	188854	COVER, air valve; aluminum	1
	3	116344	SCREW, mach, hex flange hd; M5 x 0.8; 12 mm (0.47 in.)	9
	4†◆	188618	GASKET, cover	1
	5	188855	CARRIAGE; aluminum	1
	6†◆	108730	O-RING; nitrile	1
	7†◆	188616	BLOCK, air valve; acetal	1
	8	188615	PLATE, air valve; SST	1
	9†	188617	SEAL, valve plate; buna-N	1
	10†◆	112181	PACKING, u-cup; nitrile	2
	11	188612	PISTON, actuator; acetal	2
	12	188613	BEARING, piston; acetal	2
	13‡	104765	PLUG, pipe	2
	14‡	115671	FITTING, connector,	2
	15	188611	BEARING, pin; acetal	2
	16	188610	PIN, pilot; SST	2
	17†◆	157628	O-RING; buna-N	2
	18†◆	188614	BLOCK, pilot; acetal	1
	19	188609	BEARING, shaft; acetal	2
	20	116343	SCREW, grounding	1
	22	188603	GASKET, air cover; foam	2
	23	188839	COVER, air, aluminum	2
	24	188608	SHAFT, diaphragm; SST	1
	25	115643	SCREW; M8 x 1.25; 25 mm (1 in.)	12

Digit	Ref. No.	Part No.	Description	Qty
8	Same as 7 with the following exceptions			
	1	195921	HOUSING, center; remote, aluminum	1
	23	195917	COVER, air; remote, aluminum	2
R	Same as 7 with the following exceptions			
	1	15K009	HOUSING, center, SST	1
	2	15A735	COVER, air valve; SST	1
	8◆	15H178	PLATE, air valve; SST	1
	9	-	-	-
	23	15A736	COVER, air; SST	2
	S	Same as 7 with the following exceptions		
1		15K011	HOUSING, center, remote, SST	1
2		15A735	COVER, air valve; SST	1
8◆		15H178	PLATE, air valve; SST	1
9		-	-	-
23		15B794	COVER, air; remote, SST	2

Fluid Section Parts List (Matrix Column 3)

Digit	Ref. No.	Part No.	Description	Qty
S	101	188860	COVER, fluid; SST	2
	102	15A737	MANIFOLD, inlet; SST	1
	103	15A738	MANIFOLD, outlet; SST	1
	104	188607	PLATE, air side; aluminum	2
	105	15C039	PLATE, fluid side; SST	2
	106	112178	SCREW; M8 x 1.25; 25 mm (1 in.)	24
	107	189044	BOLT; M12 x 1.75; 35 mm (1.38 in.); SST	2
	108*	104319	O-RING; PTFE	2
	110▲	188621	LABEL, warning	1
	111	112182	MUFFLER	1
	114	112257	NUT, hex; M8 x 1.25; SST	8
	X	112913	NUT, hex; 3/8-16; SST	4
	Y	112914	WASHER; SST	4
	Z	15B252	MOUNT, foot	4

Seat Parts List (Matrix Column 4)

Digit	Ref. No.	Part No.	Description	Qty
3	201*	188707	SEAT; 316 SST	4
	202*	109205	O-Ring; PTFE	8
B	201*	188707	SEAT; 316 SST	4
	202*	15B446	O-Ring; FDA fluoroelastomer	8
6	201*	191595	SEAT; Santoprene®	4
	202*	109205	O-Ring; PTFE	8
C	201*	191595	SEAT; Santoprene®	4
	202*	15B446	O-RING; PTFE	8
7	201*	15B275	SEAT; Buna-N	4
	202*	None	Not used	0
8	201*	15B633	SEAT; fluoroelastomer	4
	202*	None	Not used	0

Ball Parts List (Matrix Column 5)

Digit	Ref. No.	Part No.	Description	Qty
1	301*	112088	BALL; PTFE	4
6	301*	112092	BALL; Santoprene®	4
7	301*	15B488	BALL; buna-N	4
8	301*	15B487	BALL; fluoroelastomer	4

Diaphragm Parts List (Matrix Column 6)

Digit	Ref. No.	Part No.	Description	Qty
1	401*	188606	DIAPHRAGM; backup; TPE	2
	402*	112181	PACKING; u-cup; nitrile	2
	403*	188605	DIAPHRAGM; PTFE	2
6	401*	188857	DIAPHRAGM; Santoprene	2
	402*	112181	PACKING; u-cup; nitrile	2
7	401*	15B499	DIAPHRAGM; buna-N	2
	402*	112181	PACKING; u-cup; nitrile	2
8	401*	15B500	DIAPHRAGM; fluoroelastomer	2
	402*	112181	PACKING; u-cup; nitrile	2

Dimensional Drawing - 1040

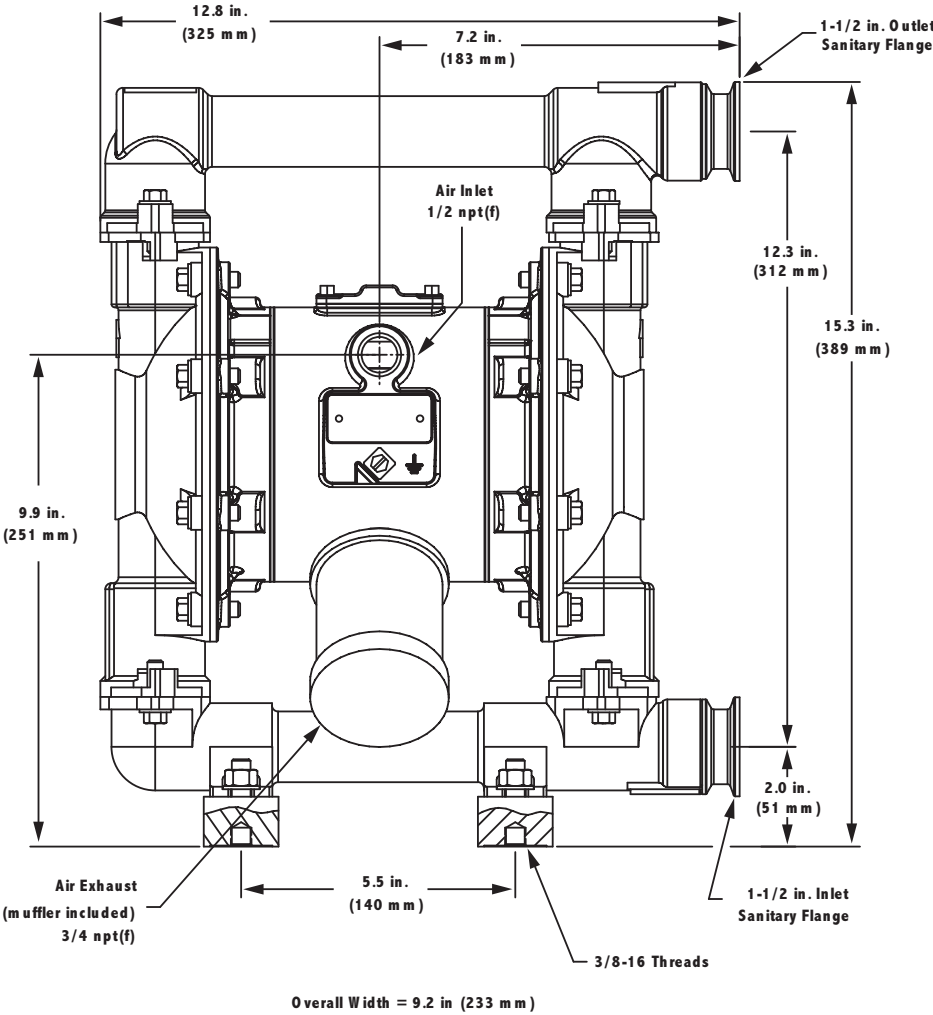

Pump Mounting Hole Pattern

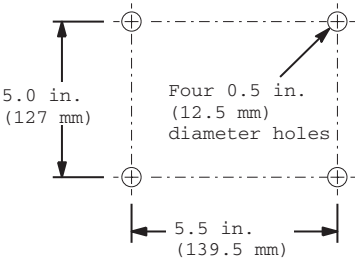

Husky 1040 FDA

Technical Data - 1040

Maximum fluid working pressure	120 psi (0.8 MPa, 8 bar)
Air pressure operating range	20-120 psi (0.14-0.8 MPa, 1.4-8 bar)
Maximum air consumption	60 scfm
Air consumption at 70 psi/20 gpm	20 scfm (see chart)
Maximum free-flow delivery	42 gpm (159 l/min)
Maximum pump speed	276 cpm
* Gallons (Liters) per cycle	0.15 (0.57)
Maximum suction lift	18 ft (5.48 m) wet or dry
Maximum size pumpable solids	1/8 in. (3.2 mm)
** Maximum Noise Level at 100 psi, full flow	89 dBa
** Sound Power Level	100 dBa
** Noise Level at 70 psi and 50 cpm	78 dBa
	PTFE 220°F (104.4°C)
Maximum fluid operating temperature is based on the fol- lowing maximum diaphragm, ball, and seat temperature ratings.	Santoprene® 180°F (82.2°C) Buna-N 180°F (82.2°C) fluoroelastomer 250°F (121.1°C) Stainless steel 250°F (121.1°C)
Air inlet size	0.5" npt(f)
Fluid inlet size	1.5" sanitary flange
Fluid outlet size	1.5" sanitary flange

Wetted parts

***All fluid contact materials are FDA-compliant and meet the United States Code of Federal Regulations (CFR) Title 21, Section 177.

All fluid contact materials are FDA-compliant.

Wetted materials on all models	316 SST, PTFE
Wetted material depending on model	316 SST, PTFE, Santoprene®, Buna-N (Nitrile), fluoroelastomer

Note: Santoprene® may be used only with non-fatty, non-oily foods or alcohols up to 15%.

Non-wetted external parts	painted aluminum, 300 series stainless steel, polyester (labels), Santoprene® (gasket), LDPE foam (gasket)
-------------------------------------	------------------------------------------------------------------------------------------------------------

Weight

Models with aluminum center sections	34 lb. (16.0 kg)
Models with stainless steel center sections	47 lb. (22.0 kg)

Santoprene® is a registered trademarks of the Monsanto Co.

Loctite® is a registered trademark of the Loctite Corporation.

**Displacement per cycle may vary based on suction condition, discharge head, air pressure, and fluid type.*

***Noise levels measured with the pump mounted on the floor, using rubber feet. Sound power measured per ISO Standard 9614-1.*

****The pump user must verify that the construction materials meet their specific application requirements.*

Performance Chart - 1040

Test Conditions: Pump tested in water with inlet submerged

Fluid Pressure Curves

- A** at 120 psi (0.7 MPa, 7 bar) air pressure
- B** at 100 psi (0.7 MPa, 7 bar) air pressure
- C** at 70 psi (0.48 MPa, 4.8 bar) air pressure
- D** at 40 psi (0.28 MPa, 2.8 bar) air pressure

To find Fluid Outlet Pressure

(psi/MPa/bar) at a specific fluid flow (gpm/lpm) and operating air pressure (psi/MPa/bar):

1. Locate fluid flow rate along bottom of chart.
2. Follow vertical line up to intersection with selected fluid outlet pressure curve.
3. Follow left to scale to read fluid outlet pressure.

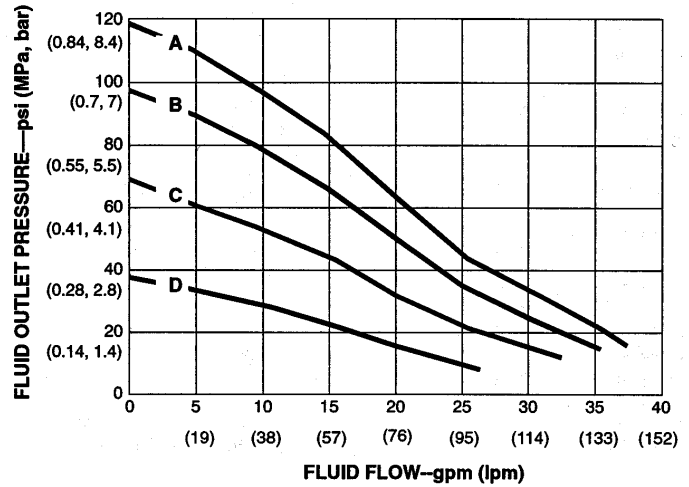

Air Consumption Curves

- A** at 120 psi (0.7 MPa, 7 bar) air pressure
- B** at 100 psi (0.7 MPa, 7 bar) air pressure
- C** at 70 psi (0.48 MPa, 4.8 bar) air pressure
- D** at 40 psi (0.28 MPa, 2.8 bar) air pressure

To find Pump Air Pressure

(scfm or m³/min) at a specific fluid flow (gpm/lpm) and operating air pressure (psi/MPa/bar):

1. Locate fluid flow rate along bottom of chart.
2. Read vertical line up to intersection with selected air consumption curve.
3. Follow left to scale to read fluid outlet pressure.

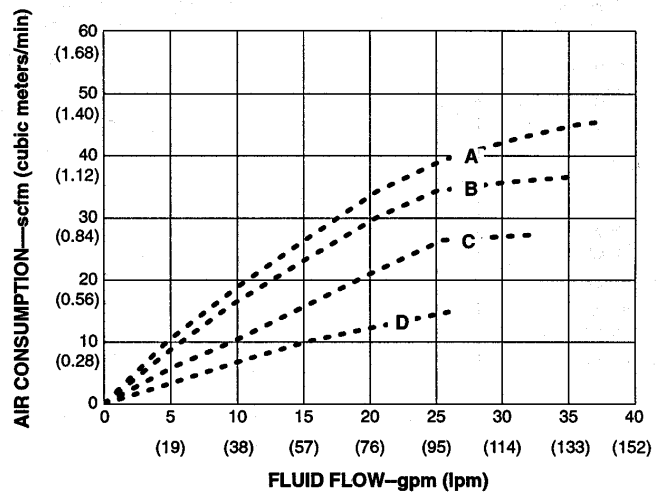

Pump Matrix - 1590

Husky 1590 Stainless Steel Sanitary Pumps

Your Model No. is marked on the pump's serial plate. To determine the Model No. of your pump from the following matrix, select the six digits which describe your pump, working from left to right. The first digit is always **D**, designating Husky diaphragm pumps. The remaining five digits define the materials of construction. For example, a pump with an aluminum air motor, stainless

steel fluid section, stainless steel seats, PTFE balls, and PTFE diaphragms is Model No. **D B S B 1 1**. To order replacement parts, refer to the part lists on pages 37-38. *The digits in the matrix **do not** correspond to the ref. nos. in the parts drawing and lists.*

Diaphragm Pump	1590 Air Motor	Fluid Section	-	Seats	Balls	Diaphragms
D (for all pumps)	B Aluminum (Standard)	S Sanitary Stainless Steel	-	3 (316 SST with PTFE o-rings)	1 (PTFE)	1 (PTFE)
	C Aluminum (Remote)		-	B (316 SST with FDA fluoroelastomer o-rings)	6 (Santoprene®)	6 (Santoprene®)
	T Stainless Steel (Standard)		-	6 (Santoprene® with PTFE o-rings)	7 (Buna-N)	7 (Buna-N)
	U Stainless Steel (Remote)		-	C (Santoprene® with FDA fluoroelastomer o-rings)	8 (fluoroelastomer)	8 (fluoroelastomer)
			-	7 (Buna-N)		
			-	8 (fluoroelastomer)		

Repair Kit Matrix - 1590

For Husky 1590 Stainless Steel Sanitary Pumps

Repair Kits may be ordered separately. To repair the air valve, order **Part No. 236273** for aluminum center housing models, or **Part No. 255061** for stainless steel center housing models (see page 28). Parts included in the Air Valve Repair Kit are marked with a symbol in the parts list, for example (4).

To repair your pump, select the six digits which describe your pump from the following matrix, working from left to right. The first digit is always **D**, the second digit is

always **0** (zero), and the third is always **B**. The remaining three digits define the materials of construction. Parts included in the kit are marked with an asterisk in the parts list, for example (201*). For example, if your pump has stainless steel seats, PTFE balls, and PTFE diaphragms, order Repair Kit **D 0 B B 1 1**. If you only need to repair certain parts (for example, the diaphragms), use the 0 (null) digits for the seats and balls, and order Repair Kit **D 0 B 0 0 1**. *The digits in the matrix **do not** correspond to the ref. nos. in the parts drawing and lists on pages 27-28.*

Diaphragm Pump	Null	Pump Size	-	Seats	Balls	Diaphragms	
D (for all pumps)	0 (for all pumps)	B 1590	-	0 (null)	0 (null)	0 (null)	
				-	3 (316 SST with PTFE o-rings)	1 (PTFE) white	1 (PTFE) white
				-	B (316 SST with FDA fluoroelastomer o-rings)	6 (Santoprene®) blue	6 (Santoprene®) blue
				-	6 (Santoprene® with PTFE o-rings)	7 (Buna-N) black	7 (Buna-N) black
				-	C (Santoprene® with FDA fluoroelastomer o-rings)	8 (fluoroelastomer) green	8 (fluoroelastomer) black
				-	7 (Buna-N) black		
				-	8 (fluoroelastomer) green		

Parts - 1590

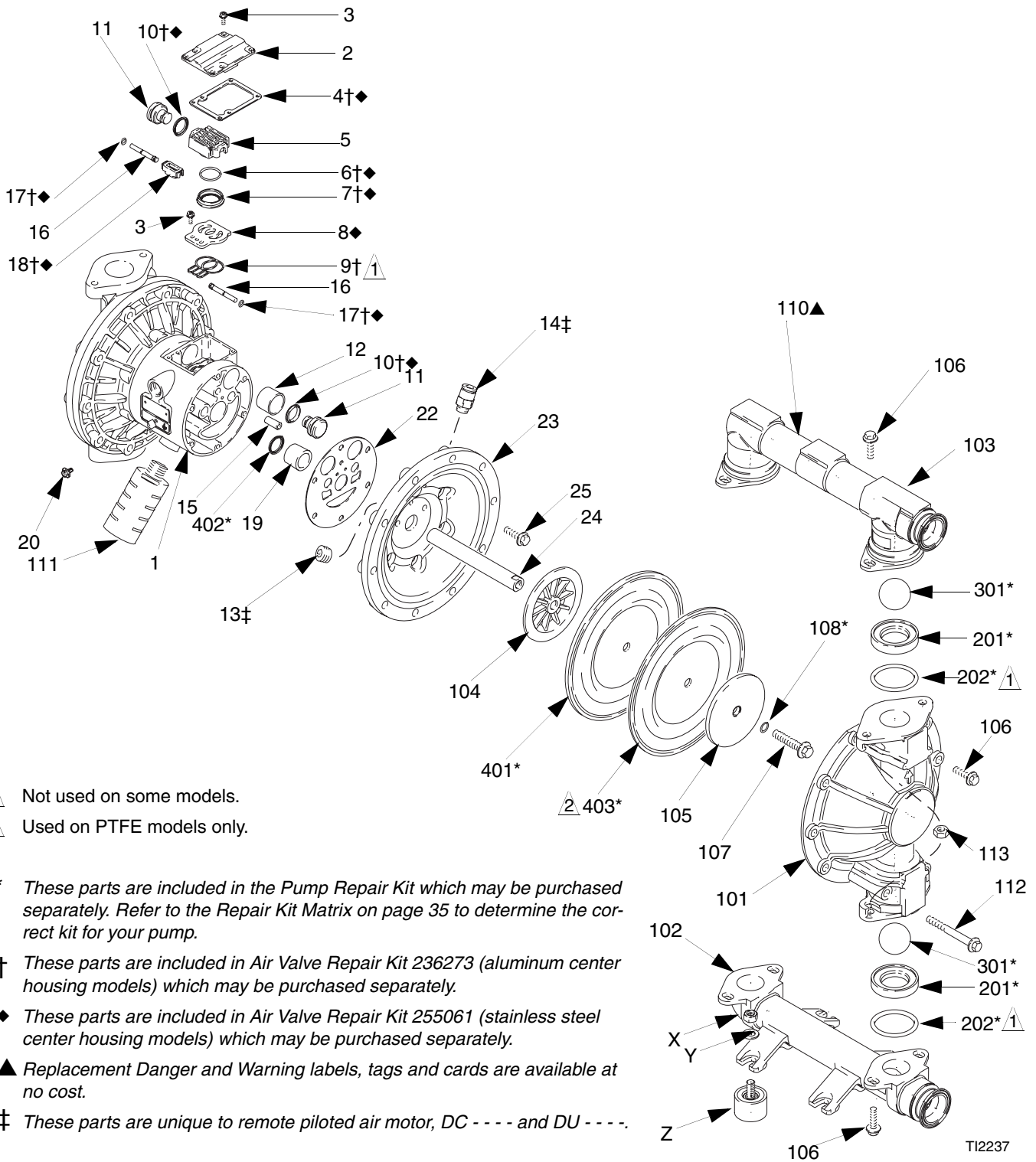

Air Motor Parts List (Matrix Column 2)

Digit	Ref. No.	Part No.	Description	Qty
B	1	188838	HOUSING, center; aluminum	1
	2	188854	COVER, air valve; aluminum	1
	3	116344	SCREW, mach, hex flange hd; M5 x 0.8; 12 mm (0.47 in.)	9
	4†◆	188618	GASKET, cover;	1
	5	188855	CARRIAGE; aluminum	1
	6†◆	108730	O-RING; nitrile	1
	7†◆	188616	BLOCK, air valve; acetal	1
	8	188615	PLATE, air valve; SST	1
	9†	188617	SEAL, valve plate; buna-N	1
	10†◆	112181	PACKING, u-cup; nitrile	2
	11	188612	PISTON, actuator; acetal	2
	12	188613	BEARING, piston; acetal	2
	13‡	104765	PLUG, pipe	2
	14‡	115671	FITTING, connector,	2
	15	188611	BEARING, pin; acetal	2
	16	188610	PIN, pilot; SST	2
	17†◆	157628	O-RING; buna-N	2
	18†◆	188614	BLOCK, pilot; acetal	1
	19	188609	BEARING, shaft; acetal	2
	20	116343	SCREW, grounding	1
	22	188603	GASKET, air cover; foam	2
	23	189400	COVER, air; aluminum	2
	24	189245	SHAFT, diaphragm; SST	1
	25	115643	SCREW; M8 x 1.25; 25 mm (1 in.)	12

Digit	Ref. No.	Part No.	Description	Qty
C	Same as B with the following exceptions			
	1	195921	HOUSING, center; remote, aluminum	1
	23	195918	COVER, air; remote, aluminum	2
T	Same as B with the following exceptions			
	1	15K009	HOUSING, center; SST	1
	2	15A735	COVER, air valve; SST	1
	8◆	15H178	PLATE, air valve; SST	1
	9	-	-	-
	23	15A739	COVER, air; SST	2
	U	Same as B with the following exceptions		
1		15K011	HOUSING, center; remote, SST	1
2		15A735	COVER, air valve; SST	1
8◆		15H178	PLATE, air valve; SST	1
9		-	-	-
23		15B795	COVER, air; remote, SST	2

Fluid Section Parts List (Matrix Column 3)

Digit	Ref. No.	Part No.	Description	Qty
S	101	194169	COVER, fluid; SST	2
	102	15A740	MANIFOLD, inlet; SST	1
	103	15A741	MANIFOLD, outlet; SST	1
	104	189308	PLATE, air side; aluminum	2
	105	189309	PLATE, fluid side; SST	2
	106	112416	SCREW; M10 x 1.25; 30 mm (1.18 in.)	24
	107	189410	BOLT; M12 x 1.75; 35 mm (1.38 in.); SST	2
	108*	104319	O-RING; PTFE	2
	110▲	188621	LABEL, warning	1
	111	102656	MUFFLER	1
	112	112417	SCREW; M10 x 1.5; 90 mm (3.54 in.); SST	4
	113	114862	NUT, hex; M10 x 1.5; SST	8
	X	112913	NUT, hex; 3/8-16; SST	4
	Y	112914	WASHER; SST	4
Z	15B252	MOUNT, foot	4	

Seat Parts List (Matrix Column 4)

Digit	Ref. No.	Part No.	Description	Qty
3	201*	189318	SEAT; 316 stainless steel	4
	202*	112418	O-Ring; PTFE	4
B	201*	189318	SEAT; 316 stainless steel	4
	202*	15B447	O-Ring; FDA fluoroelastomer	4
6	201*	189320	SEAT; Santoprene®	4
	202*	112418	O-Ring; PTFE	4
C	201*	189320	SEAT; Santoprene®	4
	202*	15B447	O-RING; FDA fluoroelastomer	4
7	201*	15B266	SEAT; Buna-N	4
	202*	None	Not used	0
8	201*	15B264	SEAT; fluoroelastomer	4
	202*	None	Not used	0

Ball Parts List (Matrix Column 5)

Digit	Ref. No.	Part No.	Description	Qty
1	301*	112419	BALL; PTFE	4
6	301*	112421	BALL; Santoprene®	4
7	301*	15B490	BALL; buna-N	4
8	301*	15B489	BALL; fluoroelastomer	4

Diaphragm Parts List (Matrix Column 6)

Digit	Ref. No.	Part No.	Description	Qty
1	401*	189426	DIAPHRAGM; backup; Santoprene®	2
	402*	112181	PACKING; u-cup; nitrile	2
	403*	189424	DIAPHRAGM; PTFE	2
6	401*	189426	DIAPHRAGM; Santoprene®	2
	402*	112181	PACKING; u-cup; nitrile	2
7	401*	15B312	DIAPHRAGM; buna-N	2
	402*	112181	PACKING; u-cup; nitrile	2
8	401*	15B501	DIAPHRAGM; fluoroelastomer	2
	402*	112181	PACKING; u-cup; nitrile	2

Dimensional Drawing - 1590

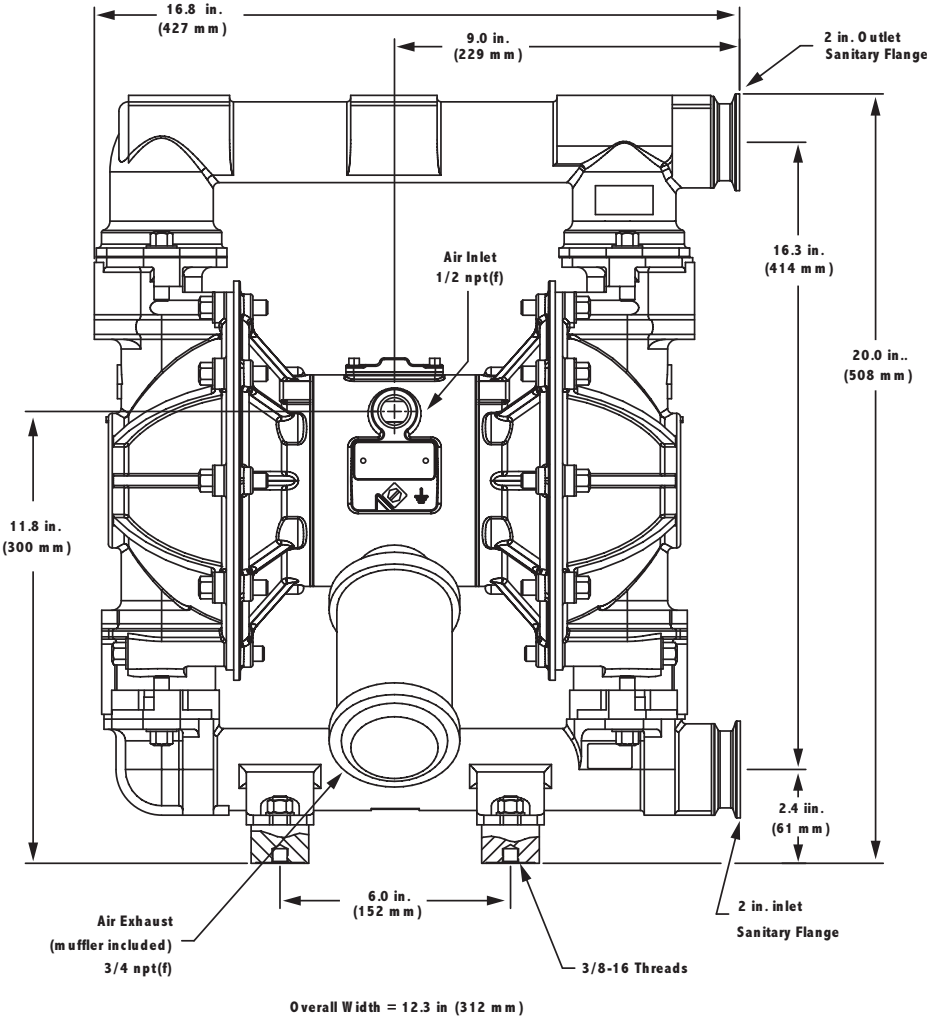

Pump Mounting Hole Pattern

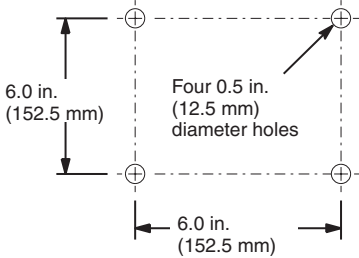

Husky 1590 FDA

Technical Data - 1590

Maximum fluid working pressure	120 psi (0.8 MPa, 8 bar)
Air pressure operating range	20-120 psi (0.14-0.8 MPa, 1.4-8 bar)
Maximum air consumption	125 scfm
Air consumption at 70 psi/20 gpm	50 scfm (see chart)
Maximum free-flow delivery	100 gpm (378.5l/min)
Maximum pump speed	200 cpm
* Gallons (Liters) per cycle	0.5 (1.9)
Maximum suction lift	18 ft (5.48 m) wet or dry
Maximum size pumpable solids	3/16 in. (4.8 mm)
** Maximum Noise Level at 100 psi, full flow	94 dBa
** Sound Power Level	108 dBa
** Noise Level at 70 psi and 50 cpm	72 dBa

PTFE 220°F (104.4°C)
Santoprene® 180°F (82.2°C)
Buna-N 180°F (82.2°C)
fluoroelastomer 250°F (121.1°C)
Stainless steel 250°F (121.1°C)

Maximum fluid operating temperature is based on the following maximum diaphragm, ball, and seat temperature ratings.

Air inlet size	0.5 in. npt(f)
Fluid inlet size	2.0 in. Sanitary flange
Fluid outlet size	2.0 in. Sanitary flange

Wetted parts

***All fluid contact materials are FDA-compliant and meet the United States Code of Federal Regulations (CFR) Title 21, Section 177.

Wetted materials on all models	316 SST, PTFE
Wetted material depending on model	316 SST, PTFE, Santoprene®, Buna-N (Nitrile), V

Note: Santoprene® may be used only with non-fatty, non-oily foods or alcohols up to 15%.

Non-wetted external parts	Painted aluminum, 300 series stainless steel, polyester (labels), Santoprene® (gasket), LDPE foam (gasket)
-------------------------------------	------------------------------------------------------------------------------------------------------------

Weight

Models with aluminum center sections	72 lb. (32.7 kg)
Models with stainless steel center sections	86 lb. (40.0 kg)

Santoprene® is a registered trademarks of the Monsanto Co.

Loctite® is a registered trademark of the Loctite Corporation.

**Displacement per cycle may vary based on suction condition, discharge head, air pressure, and fluid type.*

***Noise levels measured with the pump mounted on the floor, using rubber feet. Sound power measured per ISO Standard 9614-1.*

****The pump user must validate that the construction materials meet their specific application requirements.*

Performance Chart - 1590

Example of Finding Pump Air Consumption and Air Pressure at a Specific Fluid Delivery and Discharge Head: To supply 60 gpm (227 liters) fluid flow (horizontal scale) at 40 psi (0.28 MPa, 2.8 bar) discharge head pressure (vertical scale) requires approximately 50 scfm (1.4 m³/min) air consumption at 70 psi (0.49 MPa, 4.9 bar) inlet air pressure.

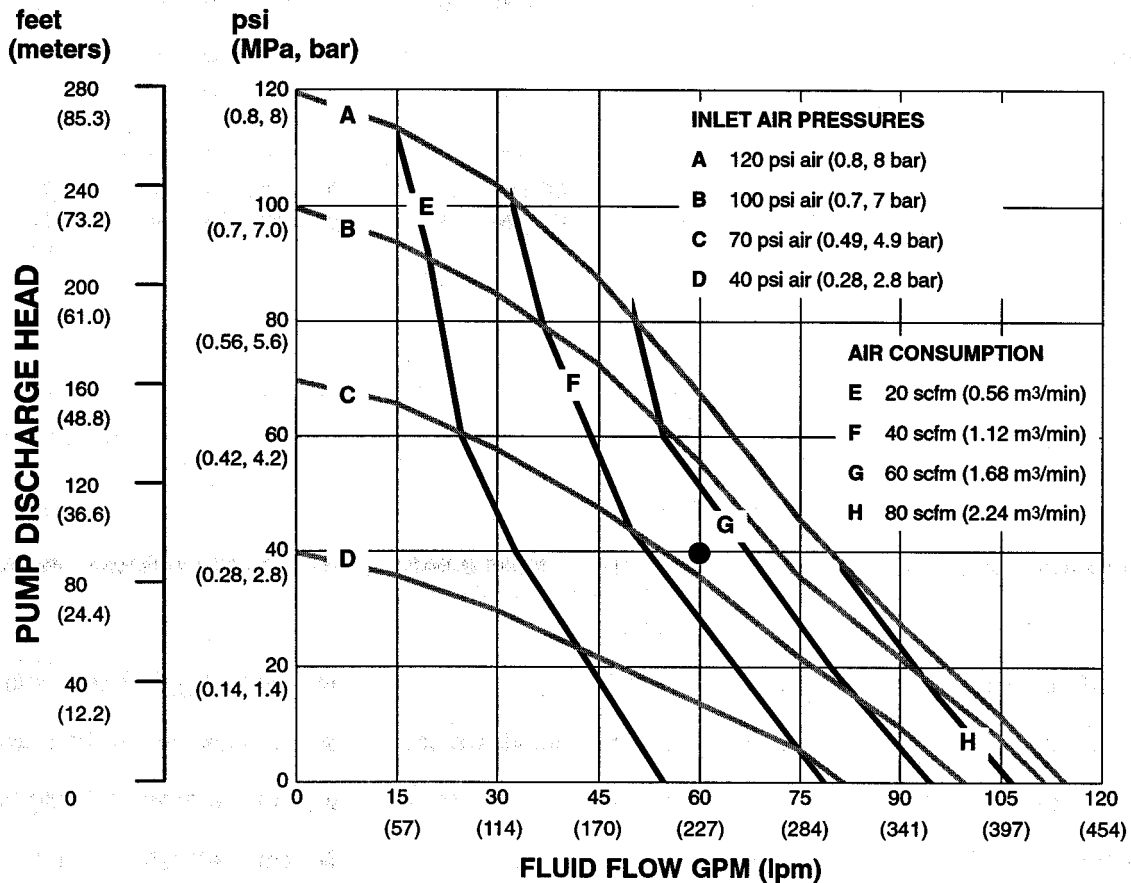

Test Conditions: Pump tested in water with PTFE diaphragm and inlet submerged

Key:
 A, B, C, D Fluid pressure and flow
 E, F, G, H scfm air consumption

Pump Matrix - 2150

Husky 2150 Stainless Steel Sanitary Pumps

Your Model No. is marked on the pump's serial plate. To determine the Model No. of your pump from the following matrix, select the six digits which describe your pump, working from left to right. The first digit is always **D**, designating Husky diaphragm pumps. The remaining five digits define the materials of construction. For example, a pump with an aluminum air motor, stainless

steel fluid section, stainless steel seats, PTFE balls, and PTFE diaphragms is Model No. **DFS B 1 1**. To order replacement parts, refer to the part lists on pages 46-48. *The digits in the matrix **do not** correspond to the ref. nos. in the parts drawing and lists on pages 22 and 23.*

Diaphragm Pump	Air Motor	Fluid Section	-	Seats	Balls	Diaphragms
D (for all pumps)	F Aluminum (Standard)	S Sanitary Stainless Steel	-	3 (316 SST with PTFE o-rings)	1 (PTFE)	1 (PTFE)
	G Aluminum (Remote)		-	B (316 SST with FDA fluoroelastomer o-rings)	6 (Santoprene®)	6 (Santoprene®)
	V Stainless Steel (Standard)		-	6 (Santoprene® with PTFE o-rings)	7 (Buna-N)	7 (Buna-N)
	W Stainless Steel (Remote)		-	C (Santoprene® with FDA fluoroelastomer o-rings)	8 (fluoroelastomer)	8 (fluoroelastomer)
			-	7 (Buna-N)		
			-	8 (fluoroelastomer)		

Model

Same as DFS666, except with different inlet and outlet configuration. Use DFS666 module to determine repair parts.

Model 234362

Same as DFS888, except with different inlet and outlet configuration. Use DFS888 module to determine repair parts.

Repair Kit Matrix - 2150

For Husky 2150 Stainless Steel Sanitary Pumps

Repair Kits may be ordered separately. To repair the air valve, order **Part No. 236273** for aluminum center housing models or **Part No. 255061** for stainless steel center housing models (see page 28). Parts included in the Air Valve Repair Kit are marked with a symbol in the parts list, for example (4†◆).

To repair your pump, select the six digits which describe your pump from the following matrix, working from left to right. The first digit is always **D**, the second digit is

always **0** (zero), and the third is always **F**. The remaining three digits define the materials of construction. Parts included in the kit are marked with an asterisk in the parts list, for example (201*). For example, if your pump has stainless steel seats, PTFE balls, and PTFE diaphragms, order Repair Kit **D 0 F B 1 1**. If you only need to repair certain parts (for example, the diaphragms), use the 0 (null) digits for the seats and balls, and order Repair Kit **D 0 F 0 0 1**. *The digits in the matrix do not correspond to the ref. nos. in the parts drawing and lists on pages 28-27.*

Diaphragm Pump	Null	Pump Size	-	Seats	Balls	Diaphragms	
D (for all pumps)	0 (for all pumps)	F 2150	-	0 (null)	0 (null)	0 (null)	
				-	3 (316 SST with PTFE o-rings)	1 (PTFE) white	1 (PTFE) white
				-	B (316 SST with FDA fluoroelastomer o-rings)	6 (Santoprene®) blue	6 (Santoprene®) blue
				-	6 (Santoprene® with PTFE o-rings)	7 (Buna-N) black	7 (Buna-N) black
				-	C (Santoprene® with FDA fluoroelastomer o-rings)	8 (fluoroelastomer) green	8 (fluoroelastomer) black
				-	7 (Buna-N) black		
				-	8 (fluoroelastomer) green		

Parts - 2150

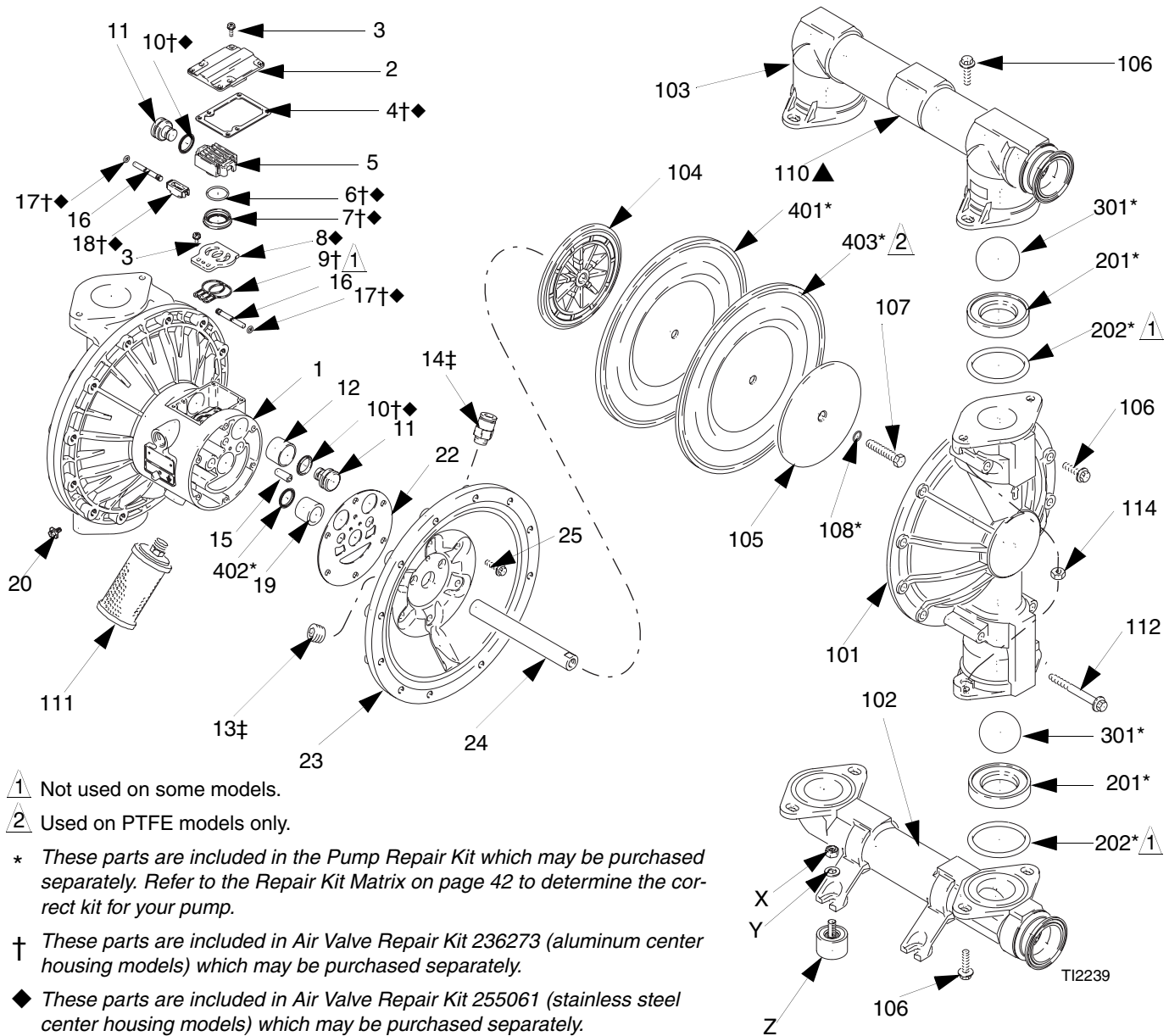

▲ 1 Not used on some models.

■ 2 Used on PTFE models only.

* These parts are included in the Pump Repair Kit which may be purchased separately. Refer to the Repair Kit Matrix on page 42 to determine the correct kit for your pump.

† These parts are included in Air Valve Repair Kit 236273 (aluminum center housing models) which may be purchased separately.

◆ These parts are included in Air Valve Repair Kit 255061 (stainless steel center housing models) which may be purchased separately.

▲ Replacement Danger and Warning labels, tags and cards are available at no cost.

‡ These parts are unique to remote piloted air motor, DG - - - - and DW - - - -.

Air Motor Parts List (Matrix Column 2)

Digit	Ref. No.	Part No.	Description	Qty
F	1	188838	HOUSING, center; aluminum	1
	2	188854	COVER, air valve; aluminum	1
	3	116344	SCREW, mach, hex flange hd; M5 x 0.8; 12 mm (0.47 in.)	9
	4†◆	188618	GASKET, cover	1
	5	188855	CARRIAGE; aluminum	1
	6†◆	108730	O-RING; nitrile	1
	7†◆	188616	BLOCK, air valve; acetal	1
	8	188615	PLATE, air valve; SST	1
	9†	188617	SEAL, valve plate; buna-N	1
	10†◆	112181	PACKING, u-cup; nitrile	4
	11	188612	PISTON, actuator; acetal	2
	12	188613	BEARING, piston; acetal	2
	13‡	104765	PLUG, pipe	2
	14‡	115671	FITTING, connector	2
	15	188611	BEARING, pin; acetal	2
	16	188610	PIN, pilot; SST	2
	17†◆	157628	O-RING; buna-N	2
	18†◆	188614	BLOCK, pilot; acetal	1
	19	188609	BEARING, shaft; acetal	2

Digit	Ref. No.	Part No.	Description	Qty
	20	116343	SCREW, grounding	1
	22	188603	GASKET, air cover; foam	2
	23	189300	COVER, air; aluminum	2
	24	189304	SHAFT, diaphragm; SST	1
	25	115643	SCREW; M8 x 1.25; 25 mm (1 in.)	12
G	Same as F with the following exceptions			
	1	195921	HOUSING, center; remote, aluminum	1
	23	195919	COVER, air; remote, aluminum	2
V	Same as F with the following exceptions			
	1	15K009	HOUSING, center, stainless steel	1
	2	15A735	COVER, air valve; stainless steel	1
	8◆	15H178	PLATE, air valve; stainless steel	1
	9	-	-	-
	23	15A742	COVER, air; stainless steel	2
	W	Same as F with the following exceptions		
1		15K011	HOUSING, center, remote, stainless steel	1
2		15A735	COVER, air valve; stainless steel	1
8◆		15H178	PLATE, air valve; stainless steel	1
9		-	-	-
23		15B796	COVER, air; remote, stainless steel	2

Fluid Section Parts List (Matrix Column 3)

Digit	Ref. No.	Part No.	Description	Qty
S	101	194279	COVER, fluid; SST	2
	102	15A743	MANIFOLD, inlet; SST	1
	102	15C737	MANIFOLD, inlet; SST; 234361 & 234362 only	2
	103	15A744	MANIFOLD, outlet; SST	1
	103	15C738	MANIFOLD, outlet; SST; 234361 & 234362 only	1
	104	188607	PLATE, air side; aluminum	2
	104	189298	PLATE, air side; aluminum; 234361 & 234362 only	2
	105	189299	PLATE, fluid side; SST	2
	106	112416	SCREW; M10 x 1.5; 30 mm (1.18 in.); SST	24
	107	189410	BOLT; M12 x 1.75; 55 mm (2.16 in.); SST	2

Digit	Ref. No.	Part No.	Description	Qty
	108*	104319	O-RING; PTFE	2
	110▲	188621	LABEL, warning	1
	111	112182	MUFFLER; not used on 234361 & 234362	1
	112	112417	SCREW; M10 x 1.5; 90 mm (3.54 in); SST	8
	114	114862	NUT, hex; M10 x 1.5; SST	8
	115	620223	CLAMP; 234361 & 234362 only	3
	116	166117	GASKET, sanitary; buna-N; 234361 & 234362 only	3
	117	15C739	CAP, end; 234361 & 234362 only; not shown	1
	X	112913	NUT, hex; 3/8-16; SST	4
	Y	112914	WASHER; SST	4
	Z	15B252	MOUNT, foot	4

Seat Parts List (Matrix Column 4)

Digit	Ref. No.	Part No.	Description	Qty
3	201*	189288	SEAT; 316 SST	4
	202*	112358	O-Ring; PTFE	4
B	201*	189288	SEAT; 316 SST	4
	202*	15B448	O-Ring; FDA fluoroelastomer	4
6	201*	189290	SEAT; Santoprene®	4
	202*	112358	O-Ring; PTFE	4
C	201*	189290	SEAT; Santoprene®	4
	202*	15B448	O-RING; FDA fluoroelastomer	4
7	201*	15B267	SEAT; Buna-N	4
	202*	None	Not used	0
8	201*	15B265	SEAT; fluoroelastomer	4
	202*	None	Not used	0

Ball Parts List (Matrix Column 5)

Digit	Ref. No.	Part No.	Description	Qty
1	301*	112359	BALL; PTFE	4
6	301*	112361	BALL; Santoprene®	4
7	301*	15B492	BALL; buna-N	4
8	301*	15B491	BALL; fluoroelastomer	4

Diaphragm Parts List (Matrix Column 6)

Digit	Ref. No.	Part No.	Description	Qty
1	401*	189296	DIAPHRAGM; backup; Santoprene®	2
	402*	112181	PACKING; u-cup; nitrile	2
	403*	189294	DIAPHRAGM; PTFE	2
6	401*	189296	DIAPHRAGM; Santoprene®	2
	402*	112181	PACKING; u-cup; nitrile	2
7	401*	15B313	DIAPHRAGM; buna-N	2
	402*	112181	PACKING; u-cup; nitrile	2
8	401*	15B502	DIAPHRAGM; fluoroelastomer	2
	402*	112181	PACKING; u-cup; nitrile	2

Dimensional Drawing - 2150

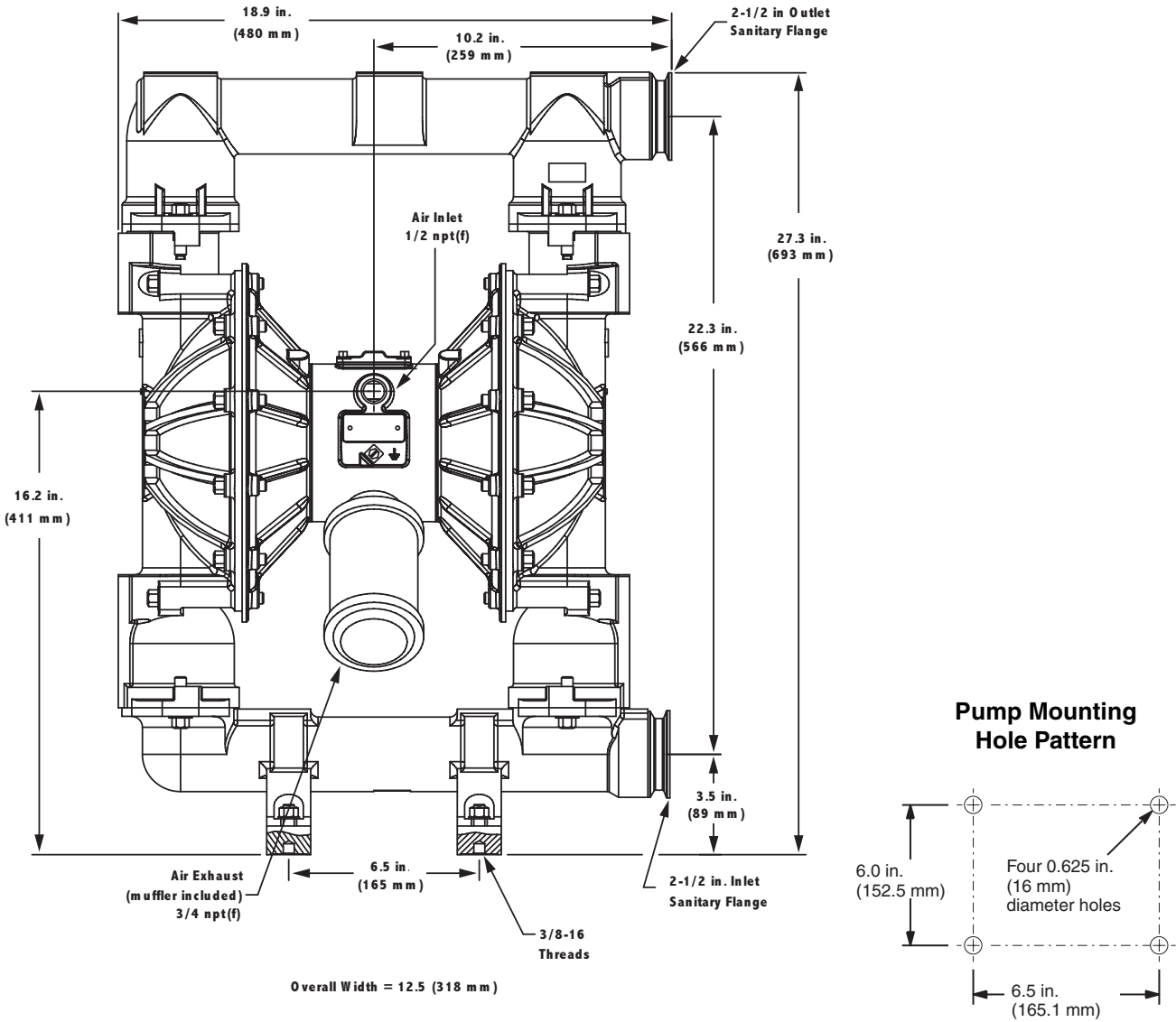

Husky 2150 FDA

Technical Data - 2150

Maximum fluid working pressure	120 psi (0.8 MPa, 8 bar)
Air pressure operating range	20-120 psi (0.14-0.8 MPa, 1.4-8 bar)
Maximum air consumption	175 scfm
Air consumption at 70 psi/20 gpm	60 scfm (see chart)
Maximum free-flow delivery	150 gpm (568 lpm)
Maximum pump speed	145 cpm
* Gallons (Liters) per cycle	1.03 (3.90)
Maximum suction lift	18 ft (5.48 m) wet or dry
Maximum size pumpable solids	1/4 in. (6.3 mm)
** Maximum Noise Level at 100 psi, full flow	90 dBa
** Sound Power Level	103 dBa
** Noise Level at 70 psi and 50 cpm	85 dBa
	PTFE 220°F (104.4°C)
Maximum fluid operating temperature is based on the fol- lowing maximum diaphragm, ball, and seat temperature ratings.	Santoprene® 180°F (82.2°C) Buna-N 180°F (82.2°C) fluoroelastomer 250°F (121.1°C) Stainless steel 250°F (121.1°C)
Air inlet size	0.5 in. npt(f)
Fluid inlet size	2.5 in. sanitary flange
Fluid outlet size	2.5 in. sanitary flange

Wetted parts

***All fluid contact materials are FDA-compliant and meet the United States Code of Federal Regulations (CFR) Title 21, Section 177.

All fluid contact materials are FDA-compliant.

Wetted materials on all models	316 SST, PTFE
Wetted material depending on model	316 SST, PTFE, Santoprene®, Buna-N (Nitrile), fluoroelastomer

Note: Santoprene® may be used only with non-fatty, non-oily foods or alcohols up to 15%.

Non-wetted external parts	Painted aluminum, 300 series stainless steel, polyester (labels), Santoprene® (gasket), LDPE foam (gasket)
-------------------------------------	------------------------------------------------------------------------------------------------------------

Weight

Models with aluminum center sections	112 lb. (50.8 kg)
Models with stainless steel center sections	134 lb. (61.0 kg)

Santoprene® is a registered trademarks of the Monsanto Co.

Loctite® is a registered trademark of the Loctite Corporation.

**Displacement per cycle may vary based on suction condition, discharge head, air pressure, and fluid type.*

***Noise levels measured with the pump mounted on the floor, using rubber feet. Sound power measured per ISO Standard 9614-1.*

****The pump user must validate that the construction materials meet their specific application requirements.*

Performance Chart - 2150

Example of Finding Pump Air Consumption and Air Pressure at a Specific Fluid Delivery and Discharge Head

Head: To supply 60 gpm (227 liters) fluid flow (horizontal scale) at 40 psi (0.28 MPa, 2.8 bar) discharge head pressure (vertical scale) requires approximately 60 scfm (1.68 m³/min) air consumption at 70 psi (0.49 MPa, 4.9 bar) inlet air pressure.

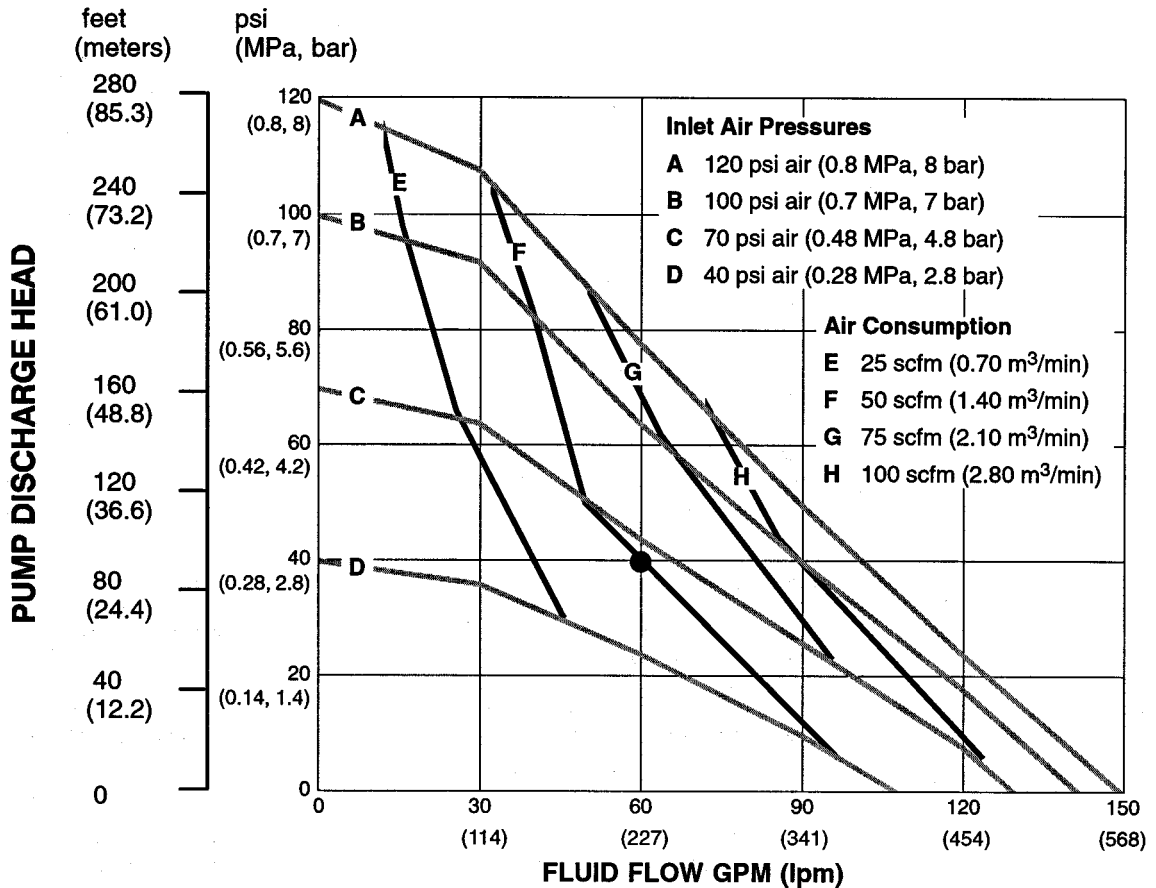

Test Conditions: Pump tested in water with PTFE diaphragm and inlet submerged

Key:
 A, B, C, D Fluid pressure and flow
 E, F, G, H scfm air consumption

Graco Warranties

Graco Standard Husky Pump Warranty

Graco warrants all equipment manufactured by Graco and bearing its name to be free from defects in material and workmanship on the date of sale to the original purchaser for use. With the exception of any special, extended, or limited warranty published by Graco, Graco will, for a period of five years from the date of sale, repair or replace any part of the equipment determined by Graco to be defective. This warranty applies only when the equipment is installed, operated and maintained in accordance with Graco's written recommendations.

This warranty does not cover, and Graco shall not be liable for general wear and tear, or any malfunction, damage or wear caused by faulty installation, misapplication, abrasion, corrosion, inadequate or improper maintenance, negligence, accident, tampering, or substitution of non-Graco component parts. Nor shall Graco be liable for malfunction, damage or wear caused by the incompatibility of Graco equipment with structures, accessories, equipment or materials not supplied by Graco, or the improper design, manufacture, installation, operation or maintenance of structures, accessories, equipment or materials not supplied by Graco.

This warranty is conditioned upon the prepaid return of the equipment claimed to be defective to an authorized Graco distributor for verification of the claimed defect. If the claimed defect is verified, Graco will repair or replace free of charge any defective parts. The equipment will be returned to the original purchaser transportation prepaid. If inspection of the equipment does not disclose any defect in material or workmanship, repairs will be made at a reasonable charge, which charges may include the costs of parts, labor, and transportation.

THIS WARRANTY IS EXCLUSIVE, AND IS IN LIEU OF ANY OTHER WARRANTIES, EXPRESS OR IMPLIED, INCLUDING BUT NOT LIMITED TO WARRANTY OF MERCHANTABILITY OR WARRANTY OF FITNESS FOR A PARTICULAR PURPOSE.

Graco's sole obligation and the buyer's sole remedy for any breach of warranty shall be as set forth above. The buyer agrees that no other remedy (including, but not limited to, incidental or consequential damages for lost profits, lost sales, injury to person or property, or any other incidental or consequential loss) shall be available. Any action for breach of warranty must be brought within six years of the date of sale.

Graco makes no warranty, and disclaims all implied warranties of merchantability and fitness for a particular purpose in connection with accessories, equipment, materials or components sold but not manufactured by Graco. These items sold, but not manufactured by Graco (such as electric motors, switches, hose, etc.), are subject to the warranty, if any, of their manufacturer. Graco will provide purchaser with reasonable assistance in making any claim for breach of these warranties.

In no event will Graco be liable for indirect, incidental, special or consequential damages resulting from Graco supplying equipment hereunder, or the furnishing, performance, or use of any products or other goods sold hereto, whether due to a breach of contract, breach of warranty, the negligence of Graco, or otherwise.

FOR GRACO CANADA CUSTOMERS

The parties acknowledge that they have required that the present document, as well as all documents, notices and legal proceedings entered into, given or instituted pursuant hereto or relating directly or indirectly hereto, be drawn up in English. Les parties reconnaissent avoir convenu que la rédaction du présente document sera en Anglais, ainsi que tous documents, avis et procédures judiciaires exécutés, donnés ou intentés, à la suite de ou en rapport, directement ou indirectement, avec les procédures concernées.

Extended Product Warranty

Graco warrants all Husky 205, 307, 515, 716, 1040, 1590, 2150, and 3275 air valve center sections to be free from defects in material and workmanship for a period of fifteen years from date installed in service by the original purchaser. Normal wear of items such as packings or seals are not considered to be defects in material and workmanship.

Five years	Graco will provide parts and labor.
Six to Fifteen years	Graco will replace defective parts only.

Graco Information

TO PLACE AN ORDER, contact your Graco distributor or call to identify the nearest distributor.

Phone: 612-623-6921 **or Toll Free:** 1-800-328-0211 **Fax:** 612-378-3505

*All written and visual data contained in this document reflects the latest product information available at the time of publication.
Graco reserves the right to make changes at any time without notice.*

This manual contains English. MM 309528

Graco Headquarters: Minneapolis
International Offices: Belgium, China, Japan, Korea

GRACO INC. P.O. BOX 1441 MINNEAPOLIS, MN 55440-1441

www.graco.com

309528L 07/2002, Revised 12/2006