

REACTOR™

309813 rev.F

Air and Hydraulic, Heated, Plural Component Proportioners

*For spraying polyurethane foam and polyurea coatings.
Not for use in explosive atmospheres.*



Important Safety Instructions

Read all warnings and instructions in this manual.
Save these instructions.

For model information, see page 4.

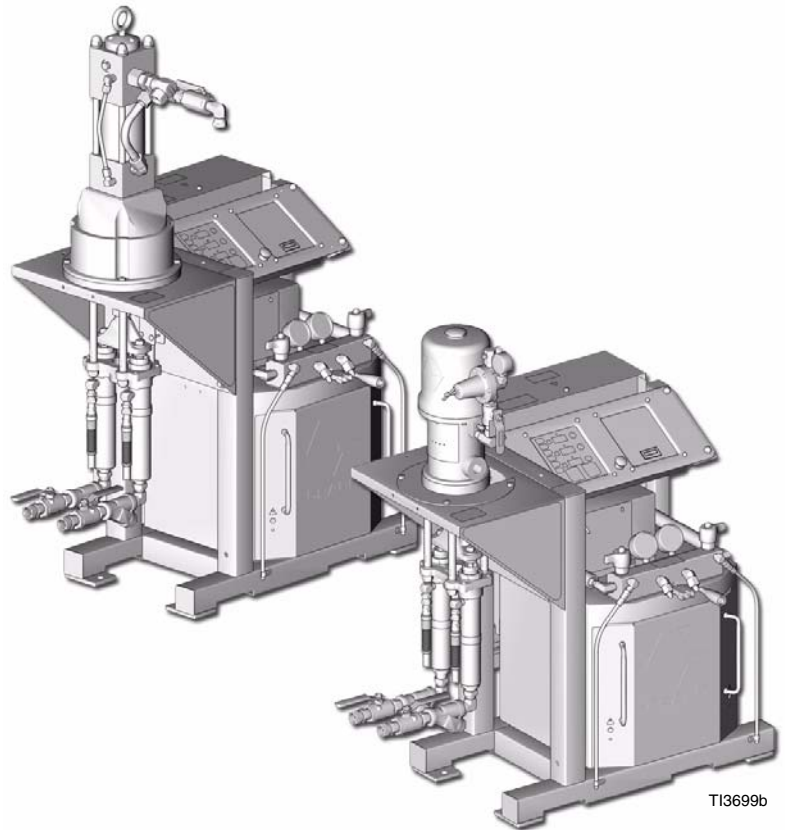



PROVEN QUALITY. LEADING TECHNOLOGY.

Contents

Manual Conventions	3	Troubleshooting	14
Models	4	Repair	17
Air Powered Reactors	4	Proportioning Pump	17
Hydraulic Powered Reactors	4	Circuit Breaker Module	18
Supplied Manuals	6	Temperature Control Board	20
Related Manuals	7	Heater	22
Warning	8	Heated Hose	25
Before Beginning Repair	10	Fluid Temperature Sensor (FTS)	26
Flushing	10	Display Module	32
Pressure Relief Procedure	11	Parts	35
Temperature Control Diagnostic Codes	12	Technical Data	58
E01: High fluid temperature	12	Graco Standard Warranty	60
E02: High hose current	12	Graco Information	60
E03: No hose current	13		
E04: FTS or thermocouple not connected	13		
E05: Board overtemperature	13		

Manual Conventions

Warning

 WARNING
 
<p>A warning alerts you to possible serious injury or death if you do not follow instructions.</p> <p>Symbols, such as fluid injection (shown), alert you to a specific hazard and direct you to read the indicated hazard warnings on pages 8-9.</p>

Caution

CAUTION
<p>A caution alerts you to possible equipment damage or destruction if you do not follow instructions.</p>

Note

 A note indicates additional helpful information.

Models

Air Powered Reactors

A SERIES

Part No., Series	Model	Voltage (phase)	Full Load Peak Amps*	System Watts**	Heater Watts (no hose)	Flow lb/min (kg/min) at 75 cpm	Output per Cycle (A + B) gal. (liter)	Maximum Fluid Working Pressure psi (MPa, bar)
246037, B	A-25	230V (1)	62	14,540	10,200	20 (9)	.031 (0.117)	1920 (13, 130)
246750, B	A-25	230V (3)	40	14,540	10,200	20 (9)	.031 (0.117)	1920 (13, 130)
246751, B	A-25	380V (3)	22	14,540	10,200	20 (9)	.031 (0.117)	1920 (13, 130)
						at 45 cpm		
246038, B	A-50	230V (1)	84	19,640	15,300	50 (22)	0.114 (0.431)	2000 (14, 140)
246754, B	A-50	230V (3)	57	19,640	15,300	50 (22)	0.114 (0.431)	2000 (14, 140)
246755, B	A-50	380V (3)	33	19,640	15,300	50 (22)	0.114 (0.431)	2000 (14, 140)

A-XP SERIES

Part No., Series	Model	Voltage (phase)	Full Load Peak Amps*	System Watts**	Heater Watts (no hose)	Flow gpm (lpm) at 78 cpm	Output per Cycle (A + B) gal. (liter)	Maximum Fluid Working Pressure psi (MPa, bar)
246639, B	A-XP2	230V (1)	62	14,540	10,200	1 (3.8)	.0193 (.073)	3000 (20.7, 207)
246752, B	A-XP2	230V (3)	40	14,540	10,200	1 (3.8)	.0193 (.073)	3000 (20.7, 207)
246753, B	A-XP2	380V (3)	22	14,540	10,200	1 (3.8)	.0193 (.073)	3000 (20.7, 207)
248635, A	A-XP2 2:1	230V (1)	62	14,540	10,200	2.3 (8.6)	.0290 (.110)	2050 (14.1, 141)
248636, A	A-XP2 2:1	230V (3)	40	14,540	10,200	2.3 (8.6)	.0290 (.110)	2050 (14.1, 141)
248637, A	A-XP2 2:1	380V (3)	22	14,540	10,200	2.3 (8.6)	.0290 (.110)	2050 (14.1, 141)

Hydraulic Powered Reactors

H-50 SERIES

Part No., Series	Model	Voltage (phase)	Full Load Peak Amps*	System Watts**	Heater Watts (no hose)	Flow lb/min (kg/min) at 45 cpm	Output per Cycle (A + B) gal. (liter)	Maximum Fluid Working Pressure psi (MPa, bar)
246039, B	H-50	230V (1)	84	19,640	15,300	50 (22.5)	0.114 (0.433)	2000 (14, 140)
246756, B	H-50	230V (3)	57	19,640	15,300	50 (22.5)	0.114 (0.433)	2000 (14, 140)
246757, B	H-50	380V (3)	33	19,640	15,300	50 (22.5)	0.114 (0.433)	2000 (14, 140)

H-XP SERIES

Part No., Series	Model	Voltage (phase)	Full Load Peak Amps*	System Watts**	Heater Watts (no hose)	Flow gpm (lpm) at 50 cpm	Output per Cycle (A + B) gal. (liter)	Maximum Fluid Working Pressure psi (MPa, bar)
246040, B	H-XP3	230V (1)	84	19,640	15,300	3.6 (13.7)	.072 (0.274)	3000 (20.7, 207)
246758, B	H-XP3	230V (3)	57	19,640	15,300	3.6 (13.7)	.072 (0.274)	3000 (20.7, 207)
246759, B	H-XP3	380V (3)	33	19,640	15,300	3.6 (13.7)	.072 (0.274)	3000 (20.7, 207)

Heat Packages (do not include proportioner)

Part No., Series	Model	Voltage (phase)	Full Load Peak Amps*	System Watts**	Heater Watts (no hose)	Maximum Fluid Working Pressures psi (MPa, bar)
246365, B	HT-6.0	230V (1)	44	10,340	6,000	3500 (24.1, 241)
246760, B	HT-6.0	230V (3)	27	10,340	6,000	3500 (24.1, 241)
246761, B	HT-6.0	380V (3)	18	10,340	6,000	3500 (24.1, 241)
246607, B	HT-10.2	230V (1)	62	14,540	10,200	3500 (24.1, 241)
246762, B	HT-10.2	230V (3)	40	14,540	10,200	3500 (24.1, 241)
246763, B	HT-10.2	380V (3)	22	14,540	10,200	3500 (24.1, 241)
246364, B	HT-15.3	230V (1)	84	19,640	15,300	3500 (24.1, 241)
246764, B	HT-15.3	230V (3)	57	19,640	15,300	3500 (24.1, 241)
246765, B	HT-15.3	380V (3)	33	19,640	15,300	3500 (24.1, 241)

* Full load amps with all devices operating at maximum capabilities. Fuse requirements at various flow rates and mix chamber sizes may be less.

** Total system watts for all units, using 310 ft (94.6 m) hose.

Supplied Manuals

The following manuals are shipped with the Reactor™. Refer to them for detailed equipment information.

Order Part No. 15B535 for a compact disk of Reactor manuals translated in several languages.

Air and Hydraulic Reactors	
Part No.	Description
309812	Air and Hydraulic Reactors, Operation Manual (English)
Proportioning Pumps (one of following included)	
Part No.	Description
308224	President® Pump (Models A-25 and A-XP2), Repair-Parts Manual (English)
307547	King® Pump (Model A-50), Repair-Parts Manual (English)
307547	Viscount® Pump (Models H-50 and H-XP3), Repair-Parts Manual (English)
Motors (one of following included)	
Part No.	Description
306982	President® Air Motor (Models A-25 and A-XP2), Repair-Parts Manual (English)
309347	King® Air Motor (Model A-50), Repair-Parts Manual (English)
307158	Viscount® Hydraulic Motor (Models H-50 and H-XP3), Repair-Parts Manual (English)
Displacement Pumps (one of following included)	
Part No.	Description
307430	Displacement Pumps (Models A-25, A-XP2, and H-XP3), Repair-Parts Manual (English)
307944	Displacement Pumps (Models A-50 and H-50), Repair-Parts Manual (English)
Reactor Electrical Diagrams (one of following included)	
Part No.	Description
309854	Electrical Diagrams, 230V 1 phase
309855	Electrical Diagrams, 230V 3 phase
309576	Electrical Diagrams, 380V 3 phase
Air Regulators (air powered units only)	
Part No.	Description
308168	Instruction-Parts Manual (English)

Related Manuals

The following manuals are for accessories used with the Reactor™.

Order Part No. 15B535 for a compact disk of Reactor manuals translated in several languages.

Order Part No. 15B381 for a compact disk of Fusion manual translated in several languages.

Hydraulic Power Supply	
Part No.	Description
307550	Instruction-Parts Manual (English)
Feed Pump Kits	
Part No.	Description
309815	Instruction-Parts Manual (English)
Air Supply Kit	
Part No.	Description
309827	Instruction-Parts Manual (English) for Feed Pump Air Supply Kit
Circulation and Return Tube Kits	
Part No.	Description
309852	Instruction-Parts Manual (English)
Heated Hose	
Part No.	Description
309572	Instruction-Parts Manual (English)
Fusion Air Purge Spray Gun	
Part No.	Description
309550	Instruction-Parts Manual (English)
Fusion Mechanical Purge Spray Gun	
Part No.	Description
309856	Instruction-Parts Manual (English)
Circulation Kit	
Part No.	Description
309818	Instruction-Parts Manual (English)
Data Reporting Kit	
Part No.	Description
309814	Instruction-Parts Manual (English)

WARNING
**SKIN INJECTION HAZARD**

High-pressure fluid from gun, hose leaks, or ruptured components will pierce skin. This may look like just a cut, but it is a serious injury that can result in amputation. **Get immediate surgical treatment.**







- Do not point the gun at anyone or at any part of the body.
- Do not put your hand or fingers over the gun fluid nozzle.
- Do not stop or deflect leaks with your hand, body, glove, or rag.
- Do not “blow back” fluid; this is not an air spray system.
- Follow **Pressure Relief Procedure**, page 11, when you stop spraying and before cleaning, checking, or servicing equipment.
- Use lowest possible pressure when flushing, priming, or troubleshooting.
- Engage spray gun piston safety lock when not spraying.
- Tighten all fluid connections before operating the equipment.
- Check hoses, tubes, and couplings daily. Replace worn or damaged parts immediately. High pressure hose cannot be recoupled; replace the entire hose.

**FIRE, EXPLOSION, AND ELECTRIC SHOCK HAZARD**

Solvent and fumes in work area can ignite or explode. High voltage components can cause electric shock. To help prevent fire, explosion, and electric shock:



- Shut off main power switch and wait 5 minutes before opening Reactor cabinet door.
- All electrical wiring must be done by trained and qualified personnel and comply with all local codes.
- Ground equipment and conductive objects. See **Grounding** in the Operation manual.
- Use equipment only in well ventilated area.
- Eliminate all ignition sources, such as pilot lights, cigarettes and plastic drop cloths (potential static arc).
- Do not plug or unplug power cords or turn lights on or off when flammable fumes are present.
- Keep the work area free of debris, including solvent, rags, and gasoline.
- Hold gun firmly to side of grounded pail when triggering into pail.
- Use only grounded hoses.
- If there is static sparking or you feel a shock, **stop operation immediately**. Do not use equipment until you identify and correct the problem.
- To avoid chemical reaction and explosion, do not use 1,1,1-trichloroethane, methylene chloride, other halogenated hydrocarbon solvents or fluids containing such solvents in pressurized aluminum equipment.

 WARNING	
	<p>EQUIPMENT MISUSE HAZARD</p> <p>Misuse can cause serious injury or death.</p> <ul style="list-style-type: none"> • For professional use only. • Use equipment only for its intended purpose. Call your Graco distributor for information. • Read manuals, warnings, tags, and labels before operating equipment. Follow instructions. • Check equipment daily. Repair or replace worn or damaged parts immediately. • Do not alter or modify equipment. Use only Graco parts and accessories. • Do not exceed the maximum working pressure or temperature rating of the lowest rated system component. See Technical Data in all equipment manuals. • Use fluids and solvents that are compatible with equipment wetted parts. See Technical Data in all equipment manuals. Read fluid and solvent manufacturer's warnings. • Route hoses and cables away from traffic areas, sharp edges, moving parts, and hot surfaces. • Do not use hoses to pull equipment. • Comply with all applicable safety regulations.
	<p>BURN HAZARD</p> <p>This equipment is used with heated fluid, which can cause equipment surfaces to become very hot. To avoid severe burns:</p> <ul style="list-style-type: none"> • Do not touch hot fluid or equipment. • Allow equipment to cool completely before touching it. • Wear gloves if fluid temperature exceeds 110°F (43°C).
	<p>TOXIC FLUID OR FUMES HAZARD</p> <p>Toxic fluids or fumes can cause serious injury or death if splashed in the eyes or on skin, inhaled, or swallowed.</p> <ul style="list-style-type: none"> • Read Material Safety Data Sheet (MSDS) to know the specific hazards of the fluids you are using. • Store hazardous fluid in approved containers, and dispose of it according to applicable guidelines.
	<p>PERSONAL PROTECTIVE EQUIPMENT</p> <p>You must wear proper protective equipment when operating, servicing, or when in the operating area of the equipment to help protect you from serious injury, including eye injury; inhalation of toxic fumes; and hearing loss. This equipment includes but is not limited to:</p> <ul style="list-style-type: none"> • Protective eyewear. • Gloves, clothing, and respirator as recommended by the fluid and solvent manufacturer. • Hearing protection.

Before Beginning Repair

WARNING



Repairing this equipment requires access to parts which may cause electric shock or other serious injury if work is not performed properly. Have a qualified electrician connect power and ground to main power switch terminals, see the Operation manual. Be sure to shut off all power to the equipment before repairing.

1. Flush if necessary, see right.
2. Trigger gun to park pumps at bottom of stroke.
3. Fill wet-cups. See operation manual.
4. Turn main power OFF 
5. Close red-handled valve to shut off power to motor.
6. Relieve pressure, page 11.

Flushing

WARNING



Read warnings, page 8. Flush equipment only in a well-ventilated area. Do not spray flammable fluids. Do not turn on heaters while flushing with flammable solvents.

- Flush out old fluid with new fluid, or flush out old fluid with a compatible solvent before introducing new fluid.
- Use the lowest possible pressure when flushing.
- All fluid components are compatible with common solvents. Use only moisture-free solvents.
- To flush feed hoses, pumps, and heaters separately from heated hoses, set PRESSURE RELIEF/SPRAY valves (SA, SB) to PRESSURE RELIEF.

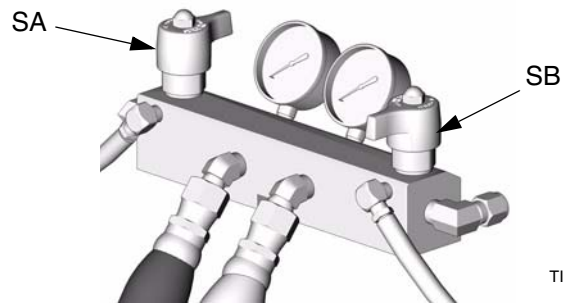

- To flush entire system, circulate through gun fluid manifold (with manifold removed from gun).
- Always leave some type of fluid in system. Do not use water.

Pressure Relief Procedure

1. Relieve pressure in gun and perform gun shutdown procedure. See gun manual.
2. Verify gun fluid manifold valves A and B are closed.

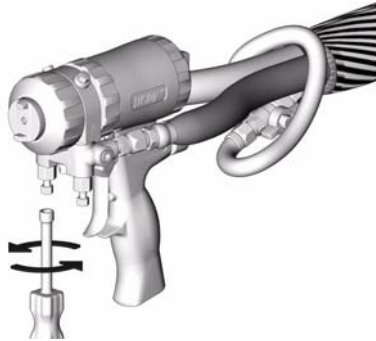

T12421A

3. Shut off feed pumps and agitator, if used.
4. Check that red-handled valve is closed, to shut off power to motor.
5. Turn PRESSURE RELIEF/SPRAY valves (SA, SB) to PRESSURE RELIEF. Route fluid to waste containers or supply tanks. Ensure gauges drop to 0.

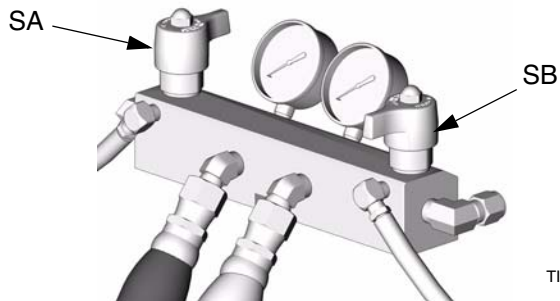

T13593a

6. Engage gun piston safety lock.



T12409A

7. Disconnect gun air line and remove gun fluid manifold.

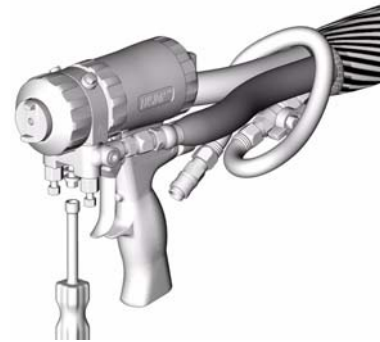

T12543A

 Pump throat seals work best under pressure. Close fluid inlet valves (VA, VB) when Reactor is depressurized, to prevent drum head pressure from leaking past pump piston seals.

8. Close fluid inlet valves (VA, VB).

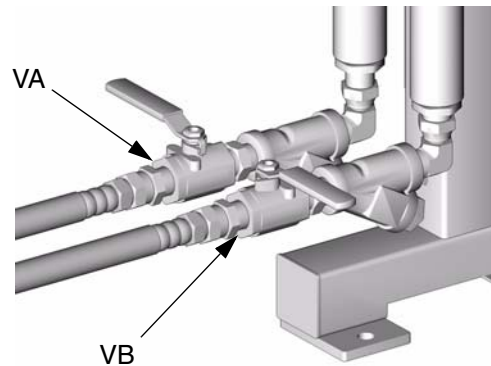

T13698b

Temperature Control Diagnostic Codes

Temperature control diagnostic codes E01 through E05 appear on temperature display.

These alarms turn off heat. Turn main power OFF

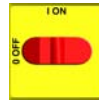

then ON



to clear.

Code No.	Code Name	Alarm Zone	Corrective Action page
01	High fluid temperature	Individual	12
02	High hose current	Hose only	12
03	No hose current with hose heater on	Hose only	13
04	FTS or thermocouple not connected	Individual	13
05	Board overtemperature	All	13



For hose zone only, if FTS is disconnected at startup, display will show hose current 0A.

E01: High fluid temperature

- a. Check connections between temperature control board and heater overtemperature switches, page 24.
- b. Check temperature sensors, page 23.
- c. Check temperature sensor is contacting heater element, page 23.

E02: High hose current

- a. Check tap connection at transformer, see operation manual.
- b. Check hose connections for electrical short, page 25.
- c. Move to lower hose length on transformer.
- d. Replace temperature control board, page 20.

E03: No hose current

Do steps in order. Do not skip any step.

- a. Check hose connectors for broken electrical connection, page 25.
- b. Test hose continuity, page 28.
- c. Test transformer wire harness continuity, page 28.
- d. Check 50A (806) and 20A (817A) circuit breakers, page 18.
- e. Test current sensor continuity, page 28.
- f. Do **Transformer Primary Check**, page 30.
- g. Do **Transformer Secondary Check**, page 30.

E04: FTS or thermocouple not connected



- a. Check FTS operation by connecting directly to Reactor.





- b. Check cable connections between all hose lengths.
- c. Check temperature sensor connection at J1 on temperature control board, page 20.
- d. Check thermocouple with ohmmeter, page 26.
- e. Use manual current control mode; see operation manual.



E05: Board overtemperature

- a. Check fan operation.
- b. Check electrical cabinet door is properly installed.
- c. Check for obstructions blocking cooling holes in bottom of Reactor.
- d. Ambient temperature too high. Reduce gun mix chamber size, or move Reactor to a cooler location.

Troubleshooting

PROBLEM	CAUSE	SOLUTION
Reactor does not operate.	No power.	Plug in power cord.
		Turn main power ON  .
		Turn circuit breakers ON, page 18.
	No air or hydraulic power.	Open red-handled valve.
	Red stop button circuit open.	Check button connections. See page 32 and electrical diagrams.
Fan not working.	Blown fuse.	Replace, page 19.
	Loose wire.	Check.
	Defective fan.	Replace, page 19.
Pump output low.	Obstructed fluid hose or gun; fluid hose ID too small.	Open, clear; use hose with larger ID.
	Worn piston valve or intake valve in displacement pump.	See pump manual.
Fluid leak in pump packing nut area.	Worn throat seals.	Replace. See pump manual.
No display.	Main power OFF.	Turn main power ON  .
	Loose display cable.	Check cable connections, page 32.
	Display board failed.	Check board, replace; page 32.
No temperature display.	Loose display cable.	Check cable connections, page 32.
	Failed temperature control board.	Open cabinet. Check if board LED is blinking. If not, check power wiring connections to ensure board has power. If board has power and LED is not blinking, replace board, page 20.
	Inadequate power to temperature board.	Check that power supply meets requirements.
	Loose power cable (internal to display).	Check cable connections, page 32.
	Defective display board.	Replace, page 32.
No cycle counter display.	Loose display cable.	Check cable connections, page 32.
	Defective counter.	Replace, page 32.
Does not count.	Magnet (26) missing from pump yoke.	Replace.
	Defective reed switch (27).	Replace.

PROBLEM	CAUSE	SOLUTION
Hose display reads 0A on startup.	FTS not installed and  zone off.	Install FTS (see operation manual), or adjust current to desired setting.
Erratic display; display turns on and off.	Cable not grounded.	Ground cable, page 32.
	Extension cable too long.	Must not exceed 100 ft (30.5 m).
Display buttons do not work properly; cannot get out of an operation.	Broken membrane switch.	Replace, page 32.
	Ribbon cable disconnected or broken.	Connect cable, or replace.
Red stop button does not work.	Broken button (fused contact).	Replace, page 32.
	Loose wire.	Check connections, page 32.
No heat in any zone.	Red stop button circuit open.	Check button connections. See page 32 and electrical diagrams.
No heat in A or B zones.	Circuit breaker(s) tripped.	Reset breaker CB3 or CB4, page 18.
	Heat turned off.	Press  or  zone  keys.
	Temperature control alarm.	Check temperature displays for diagnostic code, page 12.
	Defective heater.	Replace, page 22. Check resistance.
	Loose connectors or wire nuts.	Check connections.
	Failed temperature control board.	Open cabinet. Check if board LED is blinking. If not, check power wiring connections to ensure board has power. If board has power and LED is not blinking, replace board, page 20.
Low heat in A or B zones.	A and B temperature setpoints too low.	Check setpoint. Increase if necessary.
	Flow too high.	Use smaller mix chamber. Decrease pressure.
	Defective heater.	Replace, page 22. Check resistance.
	Loose connectors or wire nuts.	Check connections.
	Low voltage.	Check that power supply meets requirements.
	Overheated temperature control board.	Check fan operation.
		Check if door is open; close.
		Check that cooling holes are not clogged or obstructed.
Fluid too cold.	Preheat fluid.	

PROBLEM	CAUSE	SOLUTION
No hose heat.	Loose hose electrical connections.	Check connections. Repair as necessary.
	Circuit breakers tripped.	Reset breakers (CB1 or CB2), page 18.
	Hose zone not turned on.	Press  zone  key.
	A and B temperature setpoints too low.	Check. Increase if necessary.
	Failed temperature control board.	Open cabinet. Check if board LED is blinking. If not, check power wiring connections to ensure board has power. If board has power and LED is not blinking, replace board, page 20.
Low hose heat.	A and B temperature setpoints too low.	Increase A and B setpoints. Hose designed to maintain temperature, not increase temperature.
	Hose temperature setpoint too low.	Check. Increase if necessary to maintain heat.
	Flow too high.	Use smaller mix chamber. Decrease pressure.
	Low current; FTS not installed.	Install FTS, see operation manual.
	Hose heat zone not turned on long enough.	Allow hose to heat up, or preheat fluid.
	Loose hose electrical connections.	Check connections. Repair as necessary.

Repair

Proportioning Pump

Removal

1. Shut off **A** , **B** , and **Q** heat zones.
2. Flush pump, page 10.
3. Relieve pressure, page 11.
4. Turn PRESSURE RELIEF/SPRAY valves (SA, SB) to PRESSURE RELIEF.

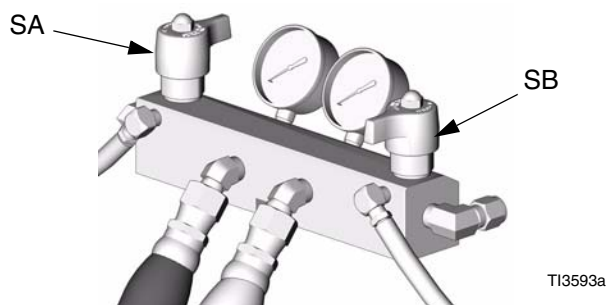

5. Turn main power OFF  . Disconnect power supply.

6. Disconnect hoses and fittings from fluid inlets (C) and outlets (D). See FIG. 1.

7. Remove pump. See applicable manuals, supplied.

 See page 6 for applicable pump and motor repair-parts manuals. Displacement pumps (E) may be removed without removing entire proportioning pump.

8. Reinstall in reverse order.

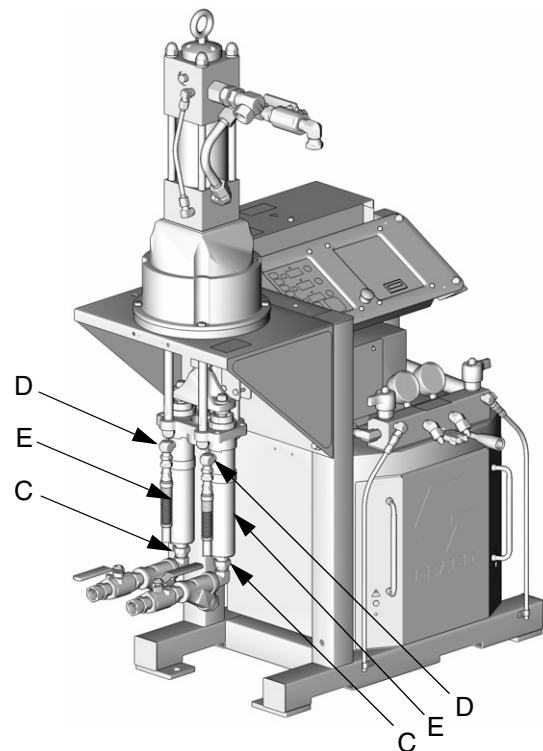

FIG. 1. Pump Removal

Circuit Breaker Module

1. Turn main power OFF . Disconnect power supply.

WARNING



Read warnings, page 8.

2. Relieve pressure, page 11.

3. Using an ohmmeter, check for continuity across circuit breaker (top to bottom). If no continuity, trip breaker, reset, and retest. If still no continuity, replace breaker as follows:
 - a. Refer to electrical diagrams and to TABLE 1. Disconnect wires and remove bad breaker.
 - b. Install new breaker and reconnect wires.

Table 1: Circuit Breakers, see FIG. 2

Ref. No.	Size	Component
806	50 A	Hose/Transformer Secondary Side
817A	20 A	Transformer Primary
804A	25 or 40 A*	Heater A
804B	25 or 40 A*	Heater B
817B	20 A	Not Used

* Depending on model.

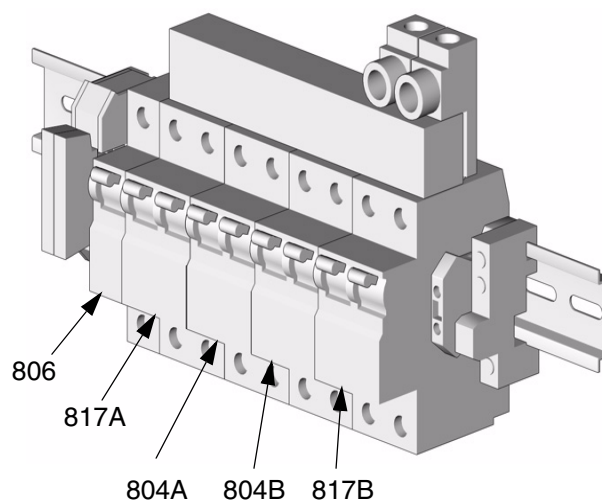

NOTE: To reference cables and connectors, see the electrical diagrams and the parts drawings on pages 53-55.

T12514A

FIG. 2. Circuit Breaker Module

Fan

1. Turn main power OFF . Disconnect power supply.

 **WARNING**



Read warnings, page 8.

2. Relieve pressure, page 11.
3. Check fuses (F) at left of breaker module, FIG. 3. Replace if blown. If good, continue with step 4.
4. Refer to electrical diagrams. Disconnect fan wires from fuses (F). Thread wires through top of cabinet.
5. Remove fan.
6. Install fan in reverse order.

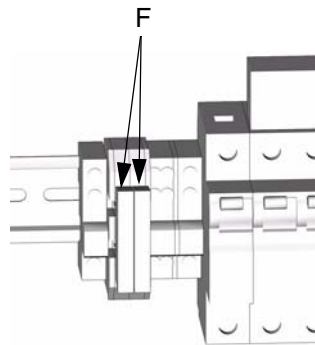

TI2514A-1

FIG. 3. Fan Fuses

Temperature Control Board

 Temperature control board has seven green LEDs. Power must be on to check. See FIG. 4 for location.

Table 2: Temperature Control Board LEDs

LED	Status	Function
D26	blinks	Board powered
D14	on	Zone A turned on
D13	cycles on and off	Zone A powered, LED cycles as temperature cycles
D18	on	Zone B turned on
D19	cycles on and off	Zone B powered, LED cycles as temperature cycles
D27	on	Hose zone turned on
D15	cycles on and off	Hose zone powered, LED cycles as temperature cycles

CAUTION

Before handling board, put on a static conductive wrist strap to protect against static discharge which can damage board. Follow instructions provided with wrist strap.

1. Turn main power OFF . Disconnect power supply.

WARNING



Read warnings, page 8.

- Relieve pressure, page 11.
- Refer to electrical diagrams. Temperature control board is on left side inside cabinet.
- Put on static conductive wrist strap.
- Disconnect all cables and connectors from board, FIG. 4.
- Remove nuts and take entire temperature control assembly to workbench.
- Remove screws and take board off heatsink.
- Install new board in reverse order. Apply thermal heatsink compound to mating surfaces of board and heatsink.



Order Part No. 110009 Thermal Compound.

Table 3: Temperature Control Board Connectors

Connector	Pin	Description	
J1	1, 2	Overtemperature switch A	
	3, 4	Overtemperature switch B	
	5, 6	Current sensor	
	7	Temperature sensor A, red	
	8	Temperature sensor A, yellow	
	9	Not used	
	10	Temperature sensor B, red	
	11	Temperature sensor B, yellow	
	12	Thermocouple, silver	
	13	Thermocouple, red	
	14	Thermocouple, purple	
	J2	n/a	To A heaters
	J5	n/a	To display board
	J8	n/a	Data reporting
J9	n/a	To B heaters	
J13	n/a	To heated hose	

⚠ Apply 110009 thermal heatsink compound to mating surfaces.

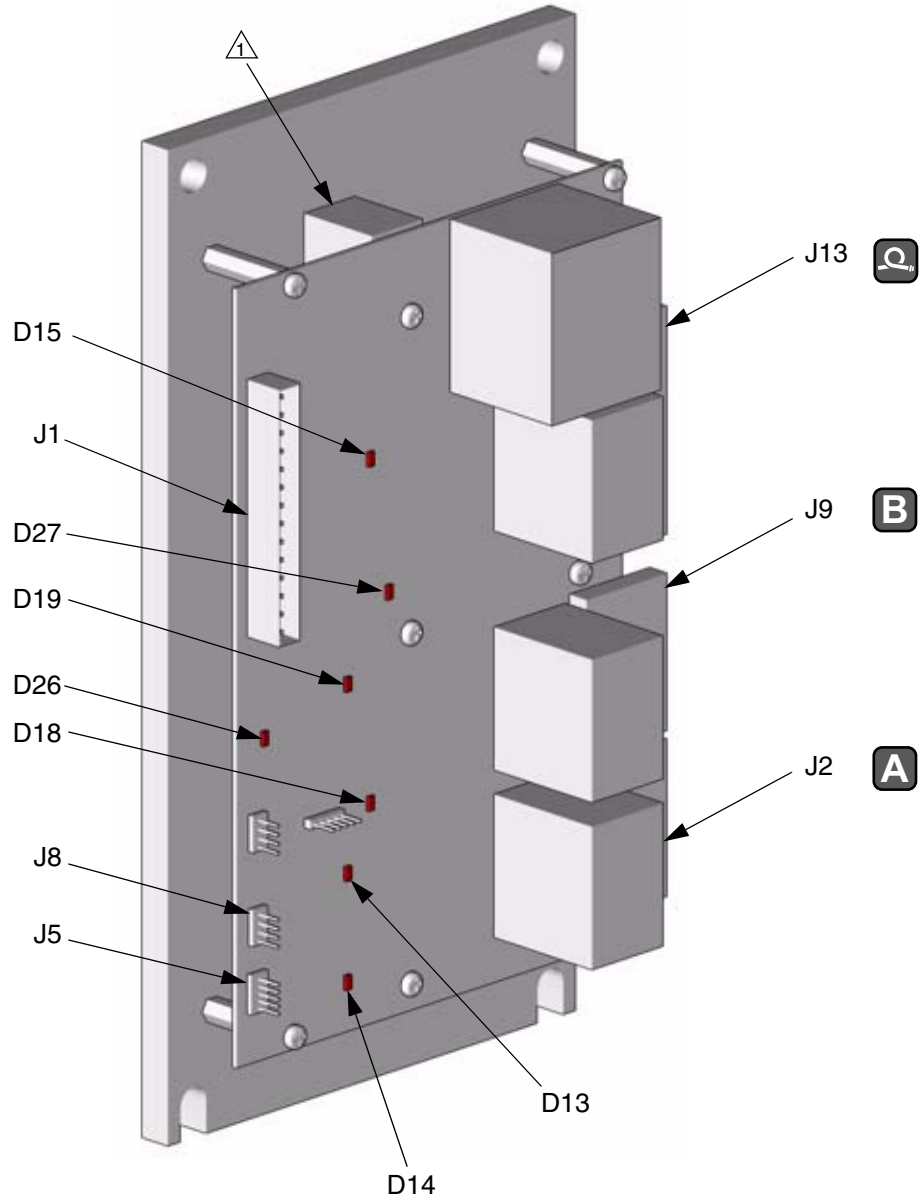

TI2572a

FIG. 4. Temperature Control Board

Heater

Heater Element

1. Turn main power OFF . Disconnect power supply.

2. Relieve pressure, page 11.

WARNING



Read warnings, page 9. Wait for heaters to cool before repairing.

3. Wait for heaters to cool.
4. See FIG. 5. Remove tape and wire connector (63, not shown), and disconnect heater element wires (W) from heater wire harness. Test with ohmmeter. Resistance must be 21-25 ohms for 2550W element, and 30-34 ohms for 1500W element.
5. If heater fails test, remove temperature sensor (211) to avoid damage.
6. Remove heater element (207) from tube (201). Be careful not to spill any fluid left in tube.
7. Install new heater element (207), holding mixer (202) so it does not interfere with sensor port (P).
8. Reinstall temperature sensor, page 23.
9. Reconnect wires and secure with connector (63) and electrical tape.

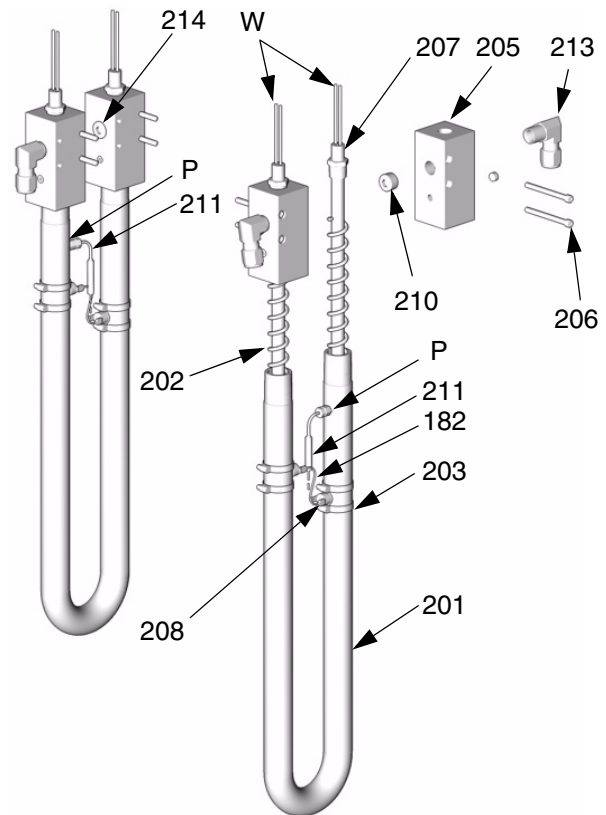

TI2512b

FIG. 5. Heater (Model 245962 Shown)

Temperature Sensor

1. Turn main power OFF . Disconnect power supply.

2. Relieve pressure, page 11.

WARNING



Read warnings, page 9. Wait for heaters to cool before repairing.

3. Wait for heaters to cool.
4. Disconnect temperature sensor wires from J1 on temperature control board. See TABLE 3, page 20 and FIG. 4, page 21.
5. See FIG. 6. Test with ohmmeter. Between wires (S), resistance must be approximately 6 ohms. Between tip (T) and wires, resistance must be infinity (∞).
6. If sensor fails test, feed wires out of cabinet. Note path as cable must be replaced in the same way.
7. Loosen ferrule nut (N). Remove temperature sensor (211) from heater tube (201), then remove sensor housing (H).
8. Replace sensor, FIG. 6.
 - a. Remove protective tape from sensor tip (T).
 - b. To ensure mixer (202) is out of the way, insert 1/4 in. drill bit into heater tube (201) to a minimum depth of 0.81 in. (20.6 mm). If minimum is not achieved, mixer must be moved before proceeding.
 - c. Apply PTFE tape and thread sealant to male threads and tighten sensor housing (H) into tube (201).

- d. Push in sensor (211) so tip (T) contacts heater element (207), avoiding mixer (202).

- e. Tighten ferrule nut (N), holding sensor (T) against heater element.

9. Route wires into cabinet and thread into bundle as before. Reconnect wires to board.

10. Turn on heaters A and B simultaneously to test. Temperatures should rise at same rate (30°F , $\pm 4^{\circ}$). If one heater is low, loosen ferrule nut (N) and tighten sensor housing (H) to ensure sensor tip (T) contacts element (207).

 Apply PTFE tape and thread sealant.

 Apply 110009 thermal heatsink compound.

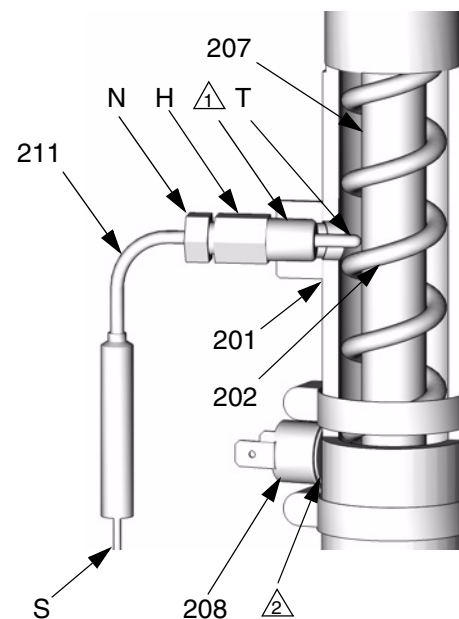

TI3249a

FIG. 6. Temperature Sensor

Overtemperature Switch

1. Turn main power OFF . Disconnect power supply.

2. Relieve pressure, page 11.



WARNING



Read warnings, page 9. Wait for heaters to cool before repairing.

3. Wait for heaters to cool.
4. Disconnect one leadwire from overtemperature switch (208), FIG. 6. Test across switch with ohmmeter. Resistance must be approximately 0 ohms.
5. If switch fails test, cut off clamps with wire clippers. Remove switch. Install new switch in same location on tube (201) and secure with hose clamps (203). Reconnect wires.



If wires need replacement, disconnect from temperature control board. See TABLE 3, page 20 and FIG. 4, page 21.

Heated Hose

 Refer to the heated hose manual 309572 for hose replacement parts.

Check Hose Connectors

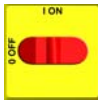
1. Turn main power OFF . Disconnect power supply.

2. Relieve pressure, page 11.

 Whip hose must be connected.

3. Disconnect hose electrical connector (D) at Reactor, FIG. 7.
4. Using an ohmmeter, check between the two terminals of hose connector (D). There should be continuity.
5. If hose fails test, retest at each length of hose, including whip hose, until failure is isolated.

Check FTS Cables

1. Turn main power OFF . Disconnect power supply.

2. Relieve pressure, page 11.

3. Disconnect FTS cable (F) at Reactor, FIG. 7.
4. Test with ohmmeter between pins of cable connector.

Pins	Result
1 to 2	approximately 35 ohms per 50 ft (15.2 m) of hose, plus approximately 10 ohms for FTS
1 to 3	infinity (∞)

5. If cable fails test, retest at FTS, page 26.

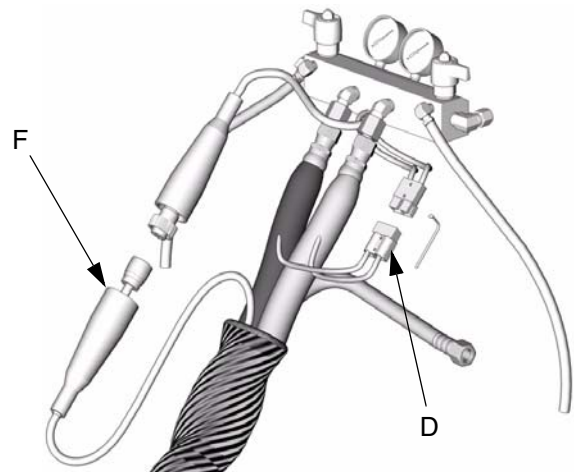

T12726a

FIG. 7. Heated Hose

Fluid Temperature Sensor (FTS)

Test/Removal

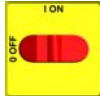
1. Turn main power OFF . Disconnect power supply.
2. Relieve pressure, page 11.
3. Remove tape and protective covering from FTS (11), FIG. 8. Disconnect hose cable (F). Test with ohmmeter between pins of cable connector.

Pins	Result
1 to 2	approximately 10 ohms
1 to 3	infinity (∞)
3 to FTS groundscrew	0 ohms
1 to FTS component A fitting (ISO)	infinity (∞)

4. If FTS fails test, replace FTS.
5. Disconnect air hoses (C, L), and electrical connectors (D).

6. Disconnect FTS from whip hose (W) and fluid hoses (A, B).
7. Remove ground wire (K) from ground screw on underside of FTS.
8. Remove FTS probe from component A (ISO) side of hose.

Installation

CAUTION

To prevent damage to probe, do not kink or excessively bend whip hose. Do not coil hose tighter than the minimum bend radius of 3 ft (0.9 m). Do not subject hose to excessive weight, impact, or other abuse.

1. Carefully extend FTS probe (H). Do not bend or kink probe. Insert in component A (ISO) side of main hose.
2. Connect whip hose ground wire (K) to ground screw on underside of FTS.
3. Install FTS in reverse order of removal. Leave slack (G) in cables as stress relief, to prevent cable failure.
4. Secure hose and cable connections with tape and install protective covering.

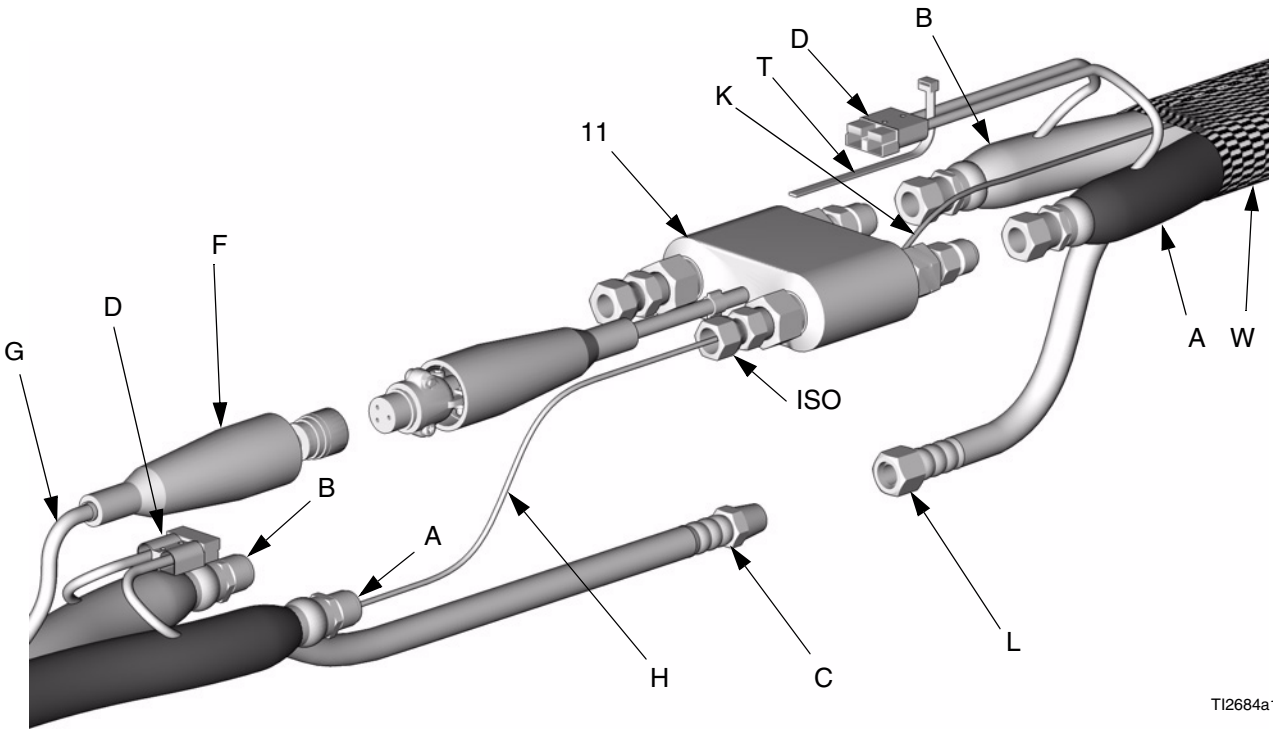

T12684a1

FIG. 8. Fluid Temperature Sensor and Heated Hoses

Transformer

Test Hose Continuity

1. Turn main power OFF . Disconnect power supply. Leave hose plugged in.
2. See FIG. 9. Disconnect 6-pin transformer connector (P) from J13 at temperature control board. Remove red wire from transformer hose length tap you are using (R).
3. Using an ohmmeter, check between pin 6 (P6) of connector (not board) and red wire. There should be continuity.
4. If test fails, trace wires until failure is located.

Test Transformer Wire Harness Continuity

1. Turn main power OFF . Disconnect power supply. Leave hose plugged in.
2. See FIG. 9. Disconnect 6-pin transformer connector (P) from J13 at temperature control board.

3. Check for continuity between:
 - a. Connector pin 1 (P1) and T1 on 20A hose circuit breaker (817A).
 - b. Connector pin 3 (P3) and T2 on 20A hose circuit breaker (817A).
 - c. Connector pin 5 (P5) and T3 on 50A hose circuit breaker (806).

Test Current Sensor Continuity

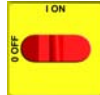
1. Turn main power OFF . Disconnect power supply.
2. Disconnect 14-pin connector from J1 on temperature control board, page 20.
3. Using an ohmmeter, test for continuity across pins 5 and 6 of connector (not board). Reading should be 20-25 ohms. If not, replace current sensor (32). See FIG. 9.

Detail B: Circuit Breaker Module and Hose Heat Wire Harness

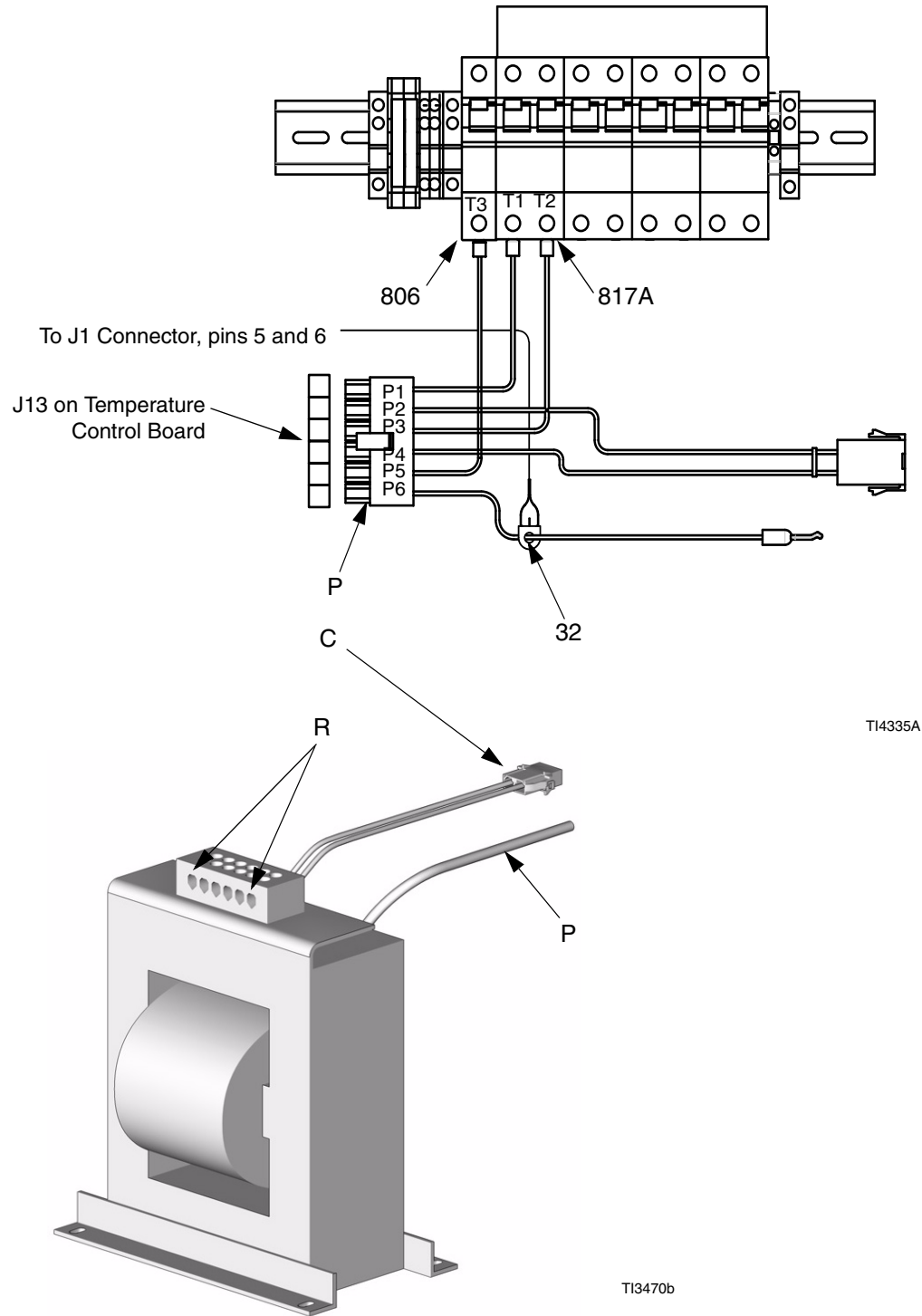

FIG. 9. Transformer Continuity Tests



Transformer Primary Check

1. Ensure that all harnesses, cables, and connectors are properly connected. Connect hose.

2. Connect power supply. Turn main power ON



3. Set hose heat target temperature below current hose temperature.

4. Turn on  heat zone by pressing .

WARNING



Read warnings, page 8. Step 5 measures line voltage and should be done by a qualified electrician. If work is not performed properly it may cause electric shock or other serious injury.

5. See FIG. 9, Detail B. Measure voltage across P2 and P4 on six-pin connector on temperature control board. Measurement should be line voltage. If not, replace temperature control board, page 20.



Transformer Secondary Check

1. Ensure that all harnesses, cables, and connectors are properly connected. Connect hose.

2. Connect power supply. Turn main power ON



3. Set hose heat target temperature below current hose temperature.

4. Turn on  heat zone by pressing .

WARNING



Read warnings, page 8. Step 5 measures line voltage and should be done by a qualified electrician. If work is not performed properly it may cause electric shock or other serious injury.

5. See FIG. 10, Detail B. Measure voltage across transformer hose tap (R) you are using and top terminal (T4) on 50A hose circuit breaker (806). See TABLE 4 for readings. If reading is correct, replace temperature control board, page 20. If reading is wrong, replace transformer, page 31.

Table 4: Transformer Voltage Readings

Transformer Tap	Reading (VAC)
50'	20
100'	34
150'	48
200'	62
250'	76
300'	90

Replace Transformer

 Use this procedure to replace transformer. To replace terminal block (B) and wire harness (C) only, order Part No. 248113 Transformer Repair Kit. See manual 309930.

1. Turn main power OFF . Disconnect power supply.

WARNING



Read warnings, page 8. Wait 5 min for stored voltage to discharge (E-30 and E-XP2 models only).

2. Open Reactor cabinet.
3. Remove bolts holding transformer to cabinet floor. Slide transformer forward.
4. Unplug 2-pin wire harness connector (C) from wire harness coming from temperature control board.
5. Disconnect the transformers secondary common wire (P) from T4 at 50 amp circuit breaker (806).
6. Remove transformer from cabinet.
7. Install new transformer in reverse order.

Detail B: Circuit Breaker Module

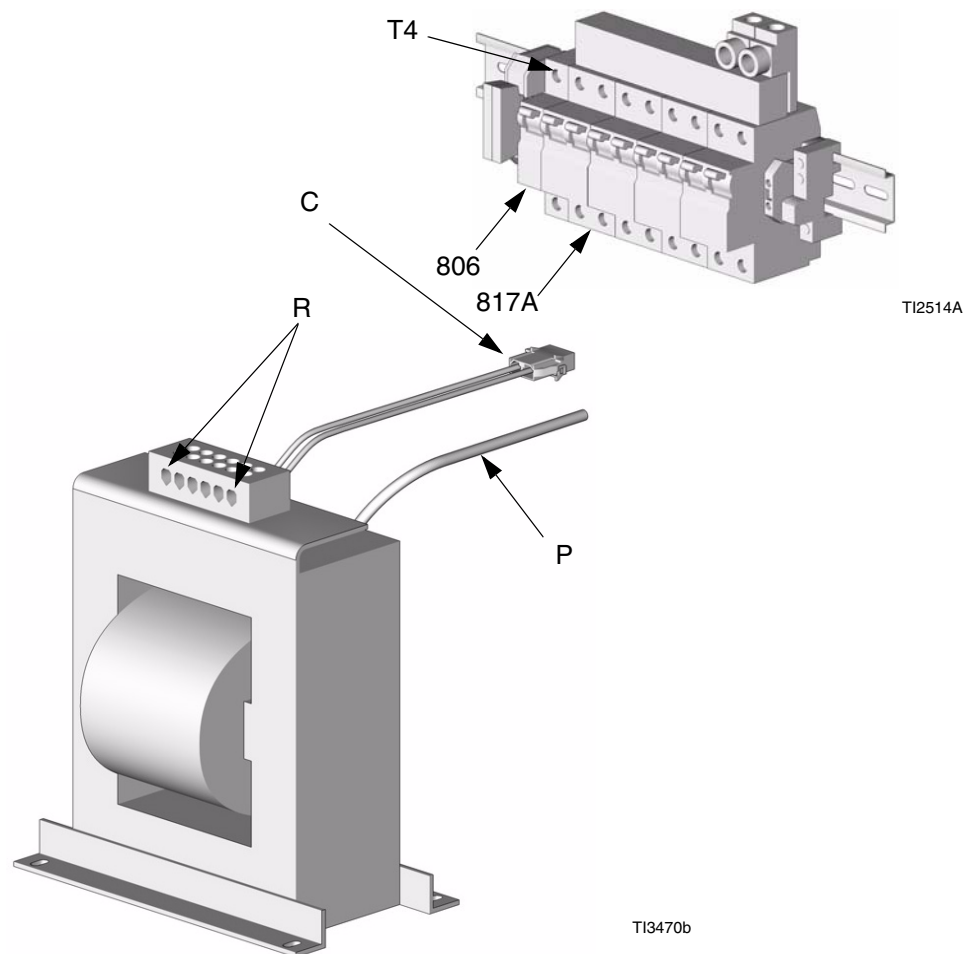

FIG. 10. Transformer

Display Module

Temperature and Cycle Counter Displays

CAUTION

Before handling board, put on a static conductive wrist strap to protect against static discharge which can damage board. Follow instructions provided with wrist strap.

1. Turn main power OFF . Disconnect power supply.

WARNING



Read warnings, page 8.

2. Relieve pressure, page 11.
3. Refer to electrical diagrams.
4. Put on static conductive wrist strap.
5. Disconnect main display cable (120) at lower left corner of display module, FIG. 11.
6. Remove screws (409, 410) and cover (404).

 If replacing both displays, label temperature display cables TEMP and cycle counter display cables CYCLES before disconnecting.

7. Disconnect cable connectors J1 and J13 from back of temperature display (402) or cycle counter display (401).
8. Disconnect ribbon cable (R) from back of display.
9. Remove nuts (408) and plate (405).
10. Disassemble display, see detail in FIG. 11.
11. Replace board (401 or 402a) or membrane switch (402b) as necessary.
12. Reassemble in reverse order, see FIG. 11. Apply medium strength thread sealant where shown. Be sure display cable ground wire (G) is secured between cable bushing and cover (404) with screws (412), FIG. 11. Also check ground connection at rear of Reactor, see below.

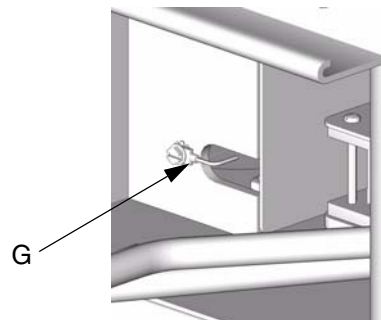

TI2603a-2

⚠ Apply medium strength thread sealant.

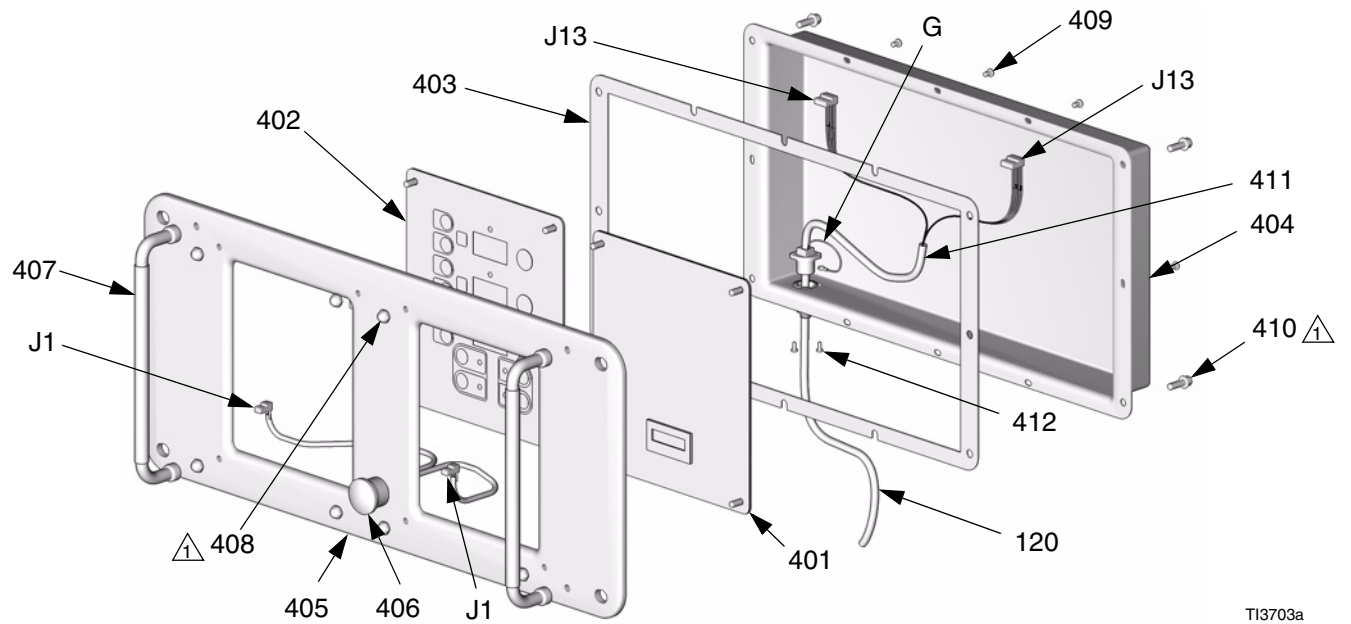

T13703a

Detail of Membrane Switches and Display Boards

Temperature Display

Cycle Counter Display

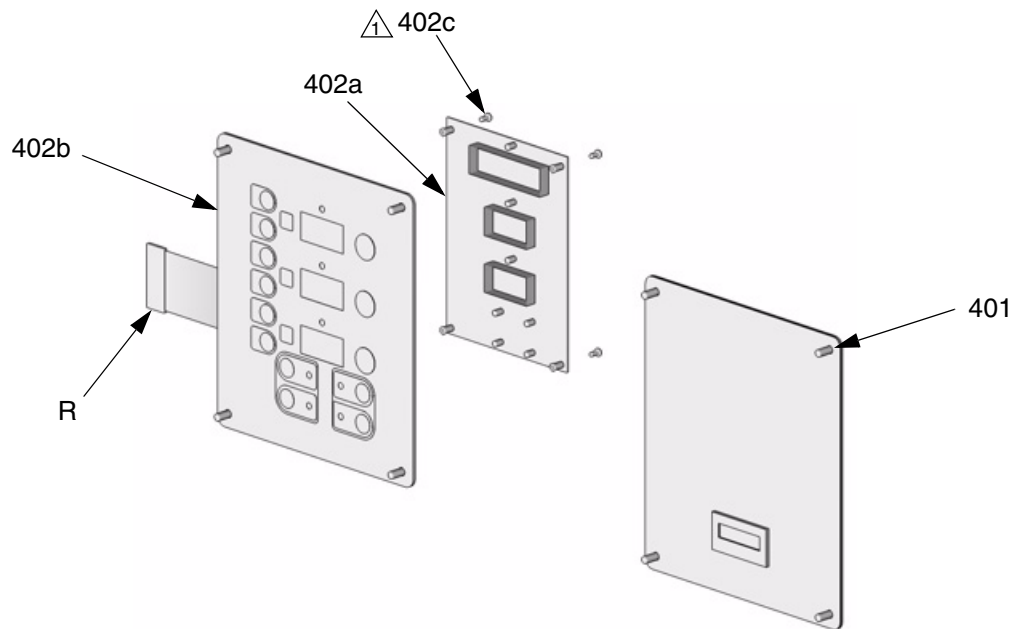

T13702a

FIG. 11. Display Module

Red Stop Button

CAUTION

Before handling board, put on a static conductive wrist strap to protect against static discharge which can damage board. Follow instructions provided with wrist strap.

1. Turn main power OFF . Disconnect power supply.

WARNING



Read warnings, page 8.

2. Relieve pressure, page 11.
3. Refer to electrical diagrams.
4. Put on static conductive wrist strap.
5. Remove screws (409, 410) and cover (404), FIG. 11.
6. Disconnect button cable connectors J1 from back of temperature display (401) and cycle counter display (402).
7. Remove red stop button (406).
8. Reassemble in reverse order. Be sure display cable ground wire (G) is secured between cable bushing and cover (404) with screws (412).

Parts

Hydraulic Reactors (Model H-XP3 Shown)

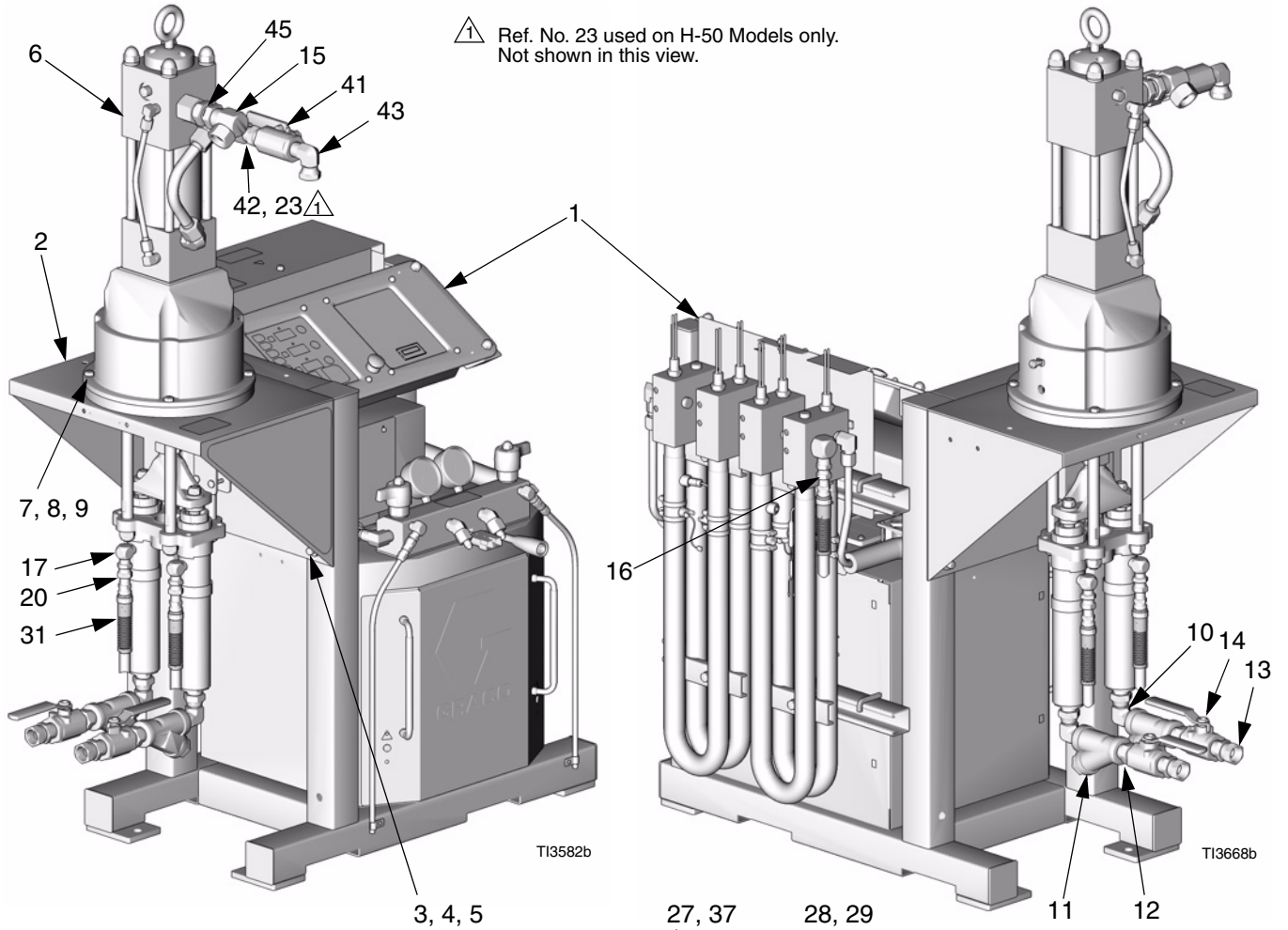

Detail of Cycle Counter Switch

△2 Ref. No. 26 Magnet is on back side of yoke.

△3 Dimension from bottom of switch mounting plate (18) to top of tie plate must be 2 in. (51 mm) to maintain correct relationship between magnet (26) and switch (27).

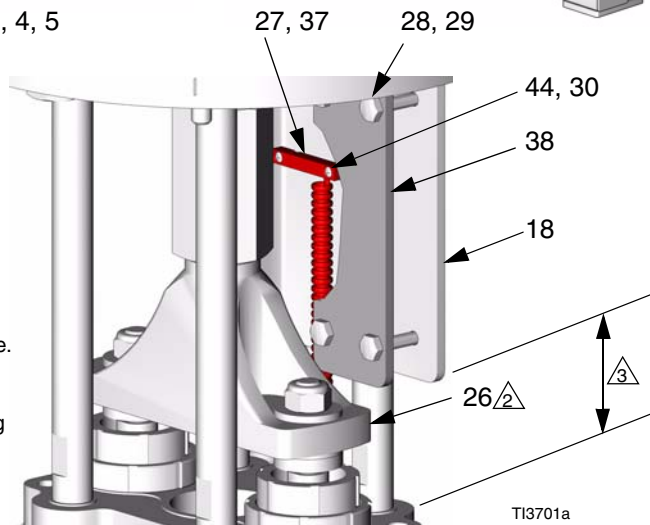

Hydraulic Reactors

Use this chart to find parts by model. Find ref. no. of part in left column, and Reactor model in top row. Intersection is correct part no.

Ref. No.	Description	Hydraulic Reactor Models						Qty
		246039 H-50	246756 H-50	246757 H-50	246040 H-XP3	246758 H-XP3	246759 H-XP3	
1	PACKAGE, control, heat; page 43	246364	246764	246765	246364	246764	246765	1
2	BRACKET, mounting	217298	217298	217298	217298	217298	217298	1
3	SCREW, cap; 1/2-13 x 3-1/2 in. (89 mm)	100679	100679	100679	100679	100679	100679	4
4	WASHER, lock; 1/2 in.	100018	100018	100018	100018	100018	100018	4
5	NUT, hex; 1/2-13	100321	100321	100321	100321	100321	100321	4
6	PUMP, proportioner; see 307547	217337	217337	217337	246041	246041	246041	1
7	SCREW, cap, hex hd; 3/8-16 x 1-3/4 in. (44 mm)	100490	100490	100490				4
	SCREW, cap, hex hd; 3/8-16 x 1-1/2 in. (38 mm)				100003	100003	100003	4
8	WASHER, lock; 3/8 in.	100133	100133	100133	100133	100133	100133	4
9	NUT, hex; 3/8-16	100131	100131	100131	100131	100131	100131	4
10	ELBOW, swivel; 1 in. npt(m) x 1 in. npt(f)	102806	102806	102806				2
	ELBOW, swivel; 3/4 npt(m) x 3/4 npt(f)				160327	160327	160327	2
11	Y-STRAINER; includes 11a	110878	110878	110878	101078	101078	101078	2
11a	. ELEMENT, 20 mesh; not shown	110907	110907	110907	180199	180199	180199	1
12	NIPPLE; 1 in. npt	118460	118460	118460				2
	NIPPLE; 3/4 npt				C20487	C20487	C20487	2
13	UNION, swivel; 1 in. npt(m) x 1 in. npsm(f)	160022	160022	160022				2
	UNION, swivel; 3/4 npt(m) x 3/4 npt(f)				157785	157785	157785	2
14	VALVE, ball; 1 in. npt (fbe)	118464	118464	118464				2
	VALVE, ball; 3/4 npt (fbe)				109077	109077	109077	2
15	ELBOW, swivel; 1 in. npt(m) x 1 in. npsm(f)				102806	102806	102806	1
16	NIPPLE; 1/2 x 3/8 npt	159239	159239	159239				4
	SWIVEL; 1/2 npt(m) x 3/8 npsm(f)				158256	158256	158256	2
17	ELBOW, street; 3/8 npt (mx f)				155699	155699	155699	2

Ref. No.	Description	Hydraulic Reactor Models						Qty
		246039 H-50	246756 H-50	246757 H-50	246040 H-XP3	246758 H-XP3	246759 H-XP3	
18	PLATE, mounting, switch	15C256	15C256	15C256	15C256	15C256	15C256	1
20	NIPPLE; 3/8 npt				156849	156849	156849	2
23	UNION, swivel; 1-1/16 in. un(f) x 3/4 npt(f)	112574	112574	112574				1
26	MAGNET	116618	116618	116618	116618	116618	116618	1
27	SWITCH, reed, with cable	117770	117770	117770	117770	117770	117770	1
28	NUT, hex flange; 1/4-20	115942	115942	115942	115942	115942	115942	4
29	SCREW, cap, hex hd; 1/4-20 x 2 in. (51 mm)	110982	110982	110982				4
	SCREW, cap, hex hd; 1/4-20 x 1-3/4 in. (44 mm)				106485	106485	106485	4
30	SCREW, machine; 5-40 x 1/2 in. (13 mm)	100974	100974	100974				2
	SCREW, machine; 5-40 x 7/8 in. (22 mm)				107438	107438	107438	2
31	HOSE, fluid; nylon; 1/2 npsm (fbc); 1/2 in. (13 mm) ID; 5 ft (1.52 m)	240632	240632	240632				2
	HOSE, fluid; nylon; 3/8 in. (10 mm) ID; 3/8 npt(fbc); 6 ft (1.8 m) long				H53806	H53806	H53806	2
36	OIL, ISO pump; not shown	217374	217374	217374	217374	217374	217374	1
37	CONNECTOR, 5 pin; 24 AWG	118115	118115	118115	118115	118115	118115	1
38	BRACKET, mounting, switch	15C319	15C319	15C319	15C319	15C319	15C319	1
41	VALVE, ball; 3/4 npt(fbc)	108537	108537	108537	108537	108537	108537	1
42	NIPPLE; 3/4 npt	C20487	C20487	C20487	C20487	C20487	C20487	1
43	ELBOW, swivel; 3/4 npt(m) x 3/4 npsm(f)				160327	160327	160327	1
44	SPACER				116374	116374	116374	2
45	UNION, swivel; 1 in. npt(m) x 1 in. npsm(f)				160022	160022	160022	1

Air Powered Reactors (Model A-XP2 Shown)

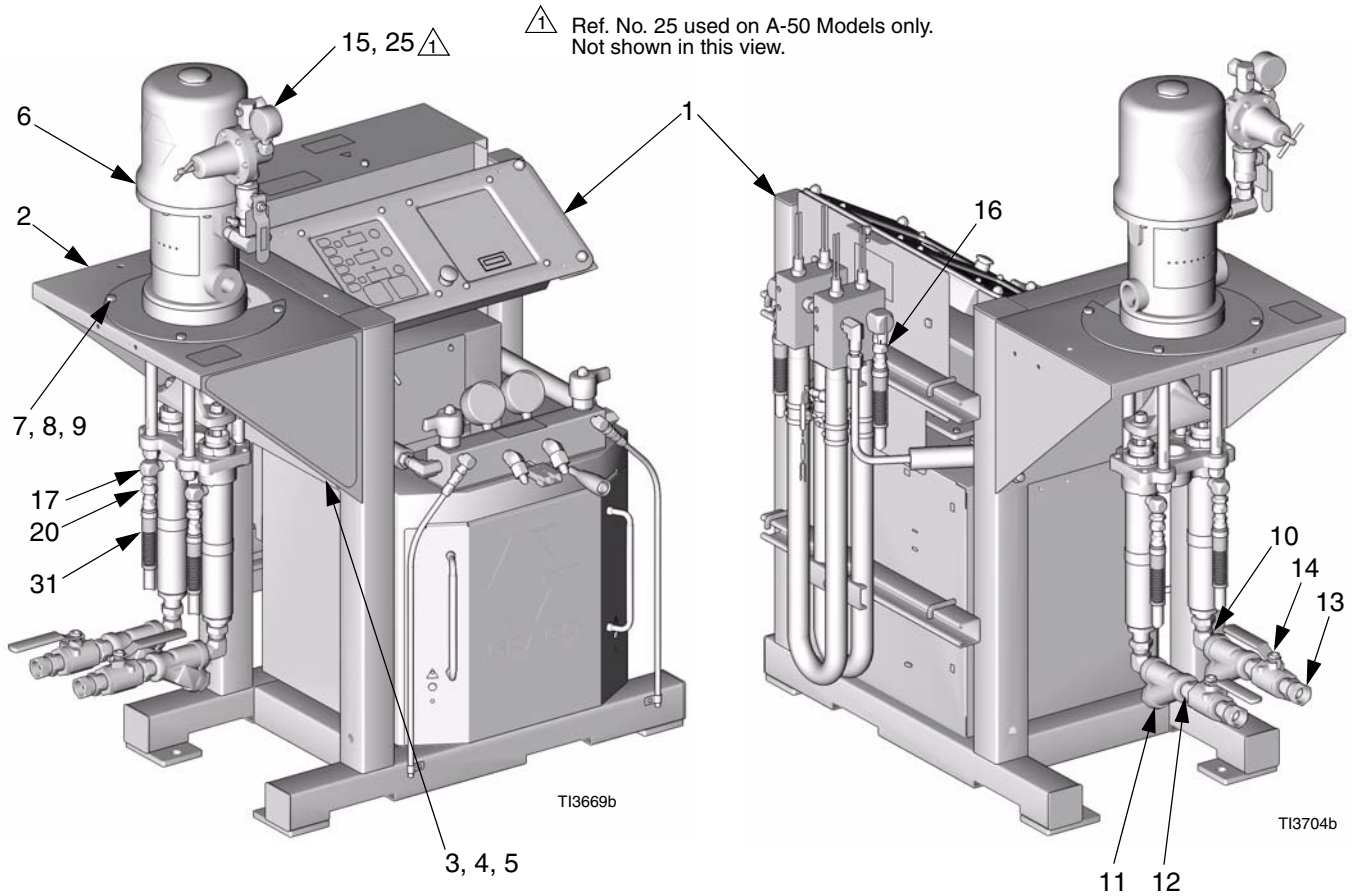

Detail of Cycle Counter Switch

△² Ref. No. 26 Magnet is on back side of yoke.

△³ Dimension from bottom of switch mounting plate (18) to top of tie plate must be 2 in. (51 mm) to maintain correct relationship between magnet (26) and switch (27).

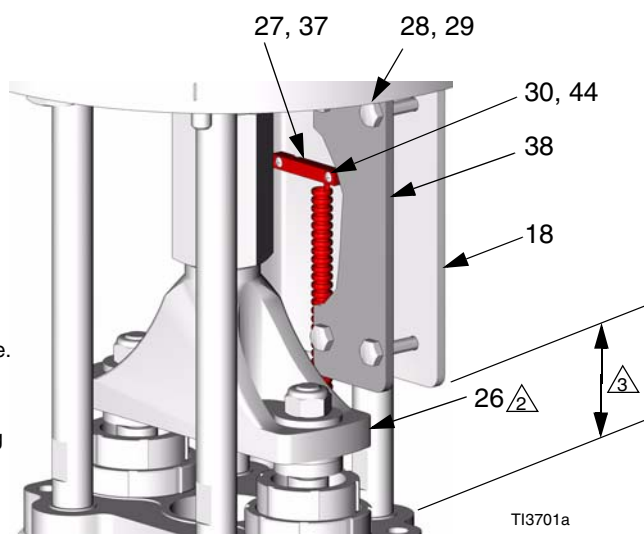

Air Powered Reactors

Use this chart to find parts by model. Find ref. no. of part in left column, and Reactor model in top row. Intersection is correct part no.

Ref. No.	Description	Air Powered Reactor Models									Qty
		246037 A-25	246750 A-25	246751 A-25	246038 A-50	246754 A-50	246755 A-50	246639 A-XP2	246752 A-XP2	246753 A-XP2	
1	PACKAGE, control, heat; page 43	246607	246762	246763	246364	246764	246765	246607	246762	246763	1
2	BRACKET, mounting	217298	217298	217298	217298	217298	217298	217298	217298	217298	1
3	SCREW, cap; 1/2-13 x 3-1/2 in. (89 mm)	100679	100679	100679	100679	100679	100679	100679	100679	100679	4
4	WASHER, lock; 1/2 in.	100018	100018	100018	100018	100018	100018	100018	100018	100018	4
5	NUT, hex; 1/2-13	100321	100321	100321	100321	100321	100321	100321	100321	100321	4
6	PUMP, proportioner; see 308224	231644	231644	231644				231646	231646	231646	1
	PUMP, proportioner; see 307547				246611	246611	246611				1
7	SCREW, cap; 3/8-16 x 1 in. (25 mm)	100101	100101	100101				100101	100101	100101	4
	SCREW, cap; 3/8-16 x 2 in. (51 mm)				100468	100468	100468				4
8	WASHER, lock; 3/8 in.	100133	100133	100133	100133	100133	100133	100133	100133	100133	4
9	NUT, hex; 3/8-16	100131	100131	100131	100131	100131	100131	100131	100131	100131	4
10	ELBOW, swivel; 3/4 npt(m) x 3/4 npt(f)	160327	160327	160327				160327	160327	160327	2
	ELBOW, swivel; 1 in. npt(m) x 1 in. npsm(f)				102806	102806	102806				2
11	Y-STRAINER; includes 11a	101078	101078	101078	110878	110878	110878	101078	101078	101078	2
11a	ELEMENT, 20 mesh; not shown	180199	180199	180199	110907	110907	110907	180199	180199	180199	1
12	NIPPLE; 3/4 npt	C20487	C20487	C20487				C20487	C20487	C20487	2
	NIPPLE; 1 in. npt				118460	118460	118460				2
13	UNION, swivel; 3/4 npt(m) x 3/4 npt(f)	157785	157785	157785				157785	157785	157785	2
	UNION, swivel; 1 in. npt(m) x 1 in. npsm(f)				160022	160022	160022				2
14	VALVE, ball; 3/4 npt (fbe)	109077	109077	109077				109077	109077	109077	2
	VALVE, ball; 1 in. npt (fbe)				118464	118464	118464				2
15	KIT, air control; see 308168	241661	241661	241661				241661	241661	241661	1
	KIT, air control; see 308168				207651	207651	207651				1
16	SWIVEL; 1/2 npt(m) x 3/8 npsm(f)	158256	158256	158256				158256	158256	158256	2
	NIPPLE; 1/2 npt				158491	158491	158491				2
17	ELBOW, street; 3/8 npt (mx f)	155699	155699	155699				155699	155699	155699	2
	ELBOW, street; 1/2 npt (mx f)				158683	158683	158683				2

Ref. No.	Description	Air Powered Reactor Models									Qty
		246037 A-25	246750 A-25	246751 A-25	246038 A-50	246754 A-50	246755 A-50	246639 A-XP2	246752 A-XP2	246753 A-XP2	
18	PLATE, mounting, switch	15C256	15C256	15C256	15C256	15C256	15C256	15C256	15C256	15C256	1
20	UNION, swivel; 3/8 npt(m) x 3/8 npsm(f)	155665	155665	155665				155665	155665	155665	2
25	VALVE, air relief; 75 psi (0.5 MPa, 5 bar)				108124	108124	108124				1
26	MAGNET	116618	116618	116618	116618	116618	116618	116618	116618	116618	1
27	SWITCH, reed, with cable	117770	117770	117770	117770	117770	117770	117770	117770	117770	1
28	NUT, hex flange; 1/4-20	115942	115942	115942	115942	115942	115942	115942	115942	115942	4
29	SCREW, cap, hex hd; 1/4-20 x 1-3/4 in. (44 mm)	106485	106485	106485				106485	106485	106485	4
	SCREW, cap, hex hd; 1/4-20 x 2 in. (51 mm)				110982	110982	110982				4
30	SCREW, machine; 5-40 x 7/8 in. (22 mm)	107438	107438	107438				107438	107438	107438	2
	SCREW, machine; 5-40 x 1/2 in. (13 mm)				100974	100974	100974				2
31	HOSE, fluid; nylon; 3/8 npt (mbe); 3/8 in. (10 mm) ID; 5 ft (1.52 m)	215247	215247	215247				215247	215247	215247	2
	HOSE, fluid; nylon; 1/2 npsm (fbe); 3/8 in. (10 mm) ID; 5 ft (1.52 m)				240632	240632	240632				2
36	OIL, ISO pump; not shown	217374	217374	217374	217374	217374	217374	217374	217374	217374	1
37	CONNECTOR, 5 pin; 24 AWG	118115	118115	118115	118115	118115	118115	118115	118115	118115	1
38	BRACKET, mounting, switch	15C319	15C319	15C319	15C319	15C319	15C319	15C319	15C319	15C319	1
44	SPACER	116374	116374	116374				116374	116374	116374	2

Air Powered Reactors (Model A-XP2 2:1 Shown)

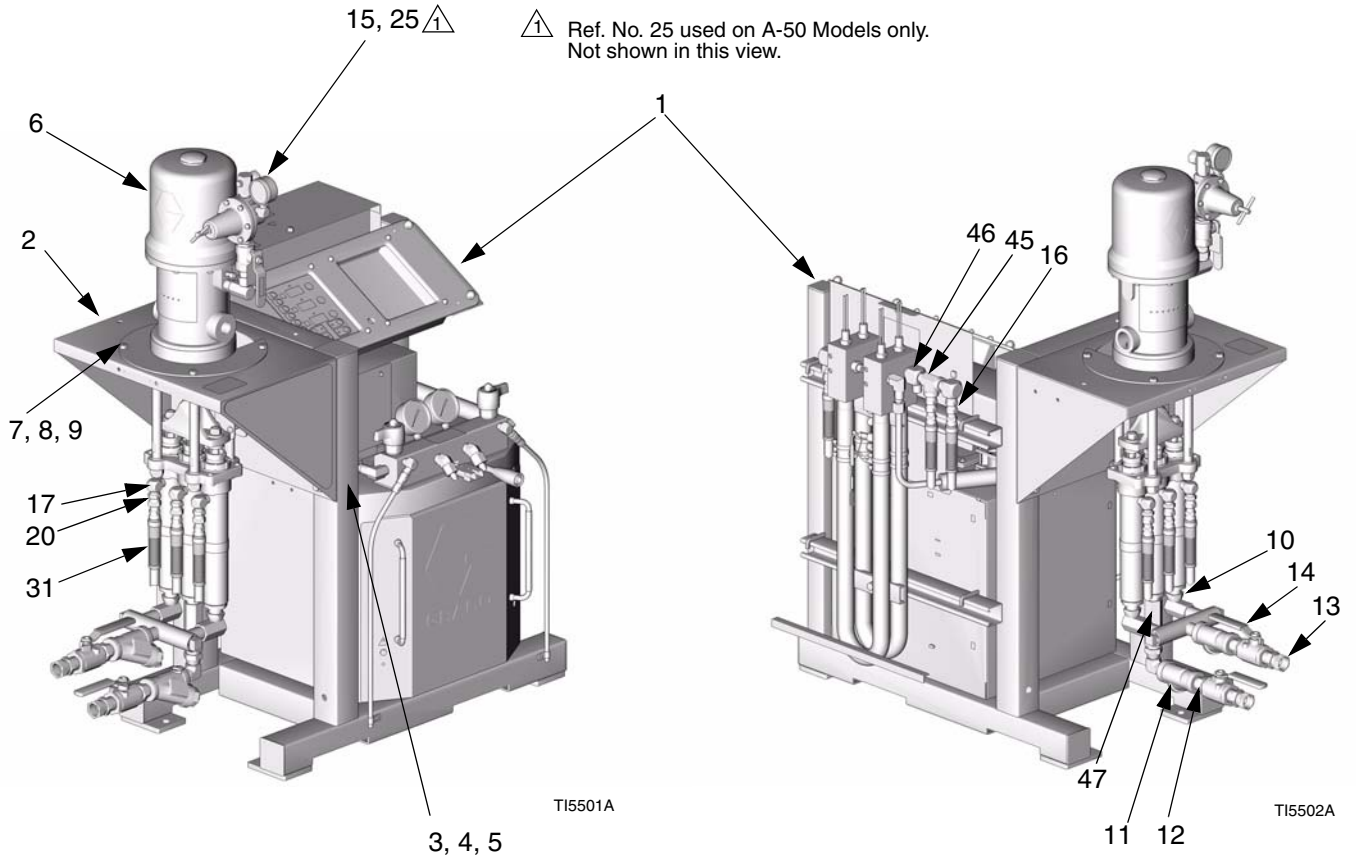

Detail of Cycle Counter Switch

Ref. No. 26 Magnet is on back side of yoke.

Dimension from bottom of switch mounting plate (18) to top of tie plate must be 2 in. (51 mm) to maintain correct relationship between magnet (26) and switch (27).

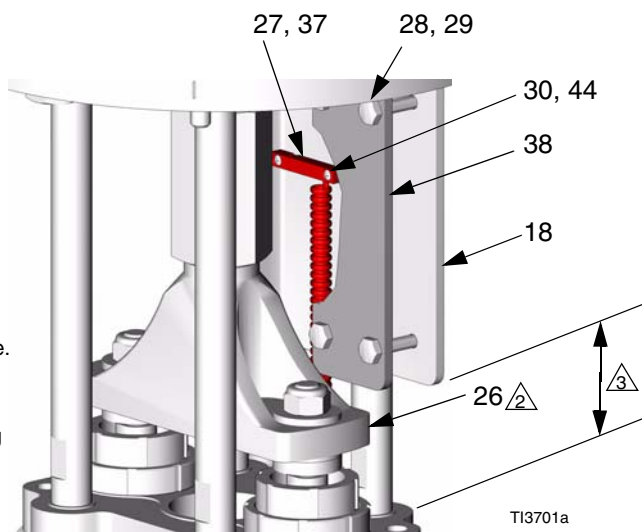

Ref. No.	Description	Air Powered Reactor Models			Qty
		248635 A-XP2 2:1	248636 A-XP2 2:1	248637 A-XP2 2:1	
1	PACKAGE, control, heat; page 43	246607	246762	246763	1
2	BRACKET, mounting	217298	217298	217298	1
3	SCREW, cap; 1/2-13 x 3-1/2 in. (89 mm)	100679	100679	100679	4
4	WASHER, lock; 1/2 in.	100018	100018	100018	4
5	NUT, hex; 1/2-13	100321	100321	100321	4
6	PUMP, proportioner; see 308224	231658	231658	231658	1
7	SCREW, cap; 3/8-16 x 1 in. (25 mm)	100101	100101	100101	4
8	WASHER, lock; 3/8 in.	100133	100133	100133	4
9	NUT, hex; 3/8-16	100131	100131	100131	4
10	ELBOW, swivel; 3/4 npt(m) x 3/4 npt(f)	118462	118462	118462	1
11	Y-STRAINER; includes 11a	101078	101078	101078	1
11a	. ELEMENT, 20 mesh; not shown	180199	180199	180199	1
12	NIPPLE; 3/4 npt	C20487	C20488	C20489	2
13	UNION, swivel; 3/4 npt(m) x 3/4 npt(f)	118459	118459	118459	2
14	VALVE, ball; 3/4 npt (fbe)	109077	109077	109077	2
15	KIT, air control; see 308168	241661	241661	241661	1
16	SWIVEL; 1/2 npt(m) x 3/8 npsm(f)	158256	158256	158256	3
17	ELBOW, street; 3/8 npt (mxf)	155699	155699	155699	3
18	PLATE, mounting, switch	15C256	15C257	15C258	1
20	UNION, swivel; 3/8 npt(m) x 3/8 npsm(f)	155665	155665	155665	3
26	MAGNET	116618	116618	116618	1
27	SWITCH, reed, with cable	117770	117770	117770	1
28	NUT, hex flange; 1/4-20	115942	115942	115942	4
29	SCREW, cap, hex hd; 1/4-20 x 1-3/4 in. (44 mm)	106485	106485	106485	4
30	SCREW, machine; 5-40 x 7/8 in. (22 mm)	107438	107438	107438	4
31	HOSE, fluid; nylon; 3/8 npt (mbe); 3/8 in. (10 mm) ID; 5 ft (1.52 m)	215247	215247	215247	3
36	OIL, ISO pump; not shown	217374	217374	217374	1
37	CONNECTOR, 5 pin; 24 AWG	118115	118115	118115	1
38	BRACKET, mounting, switch	15C319	15C320	15C321	1
44	SPACER	116374	116375	116376	2
45	TEE, street	108126	108126	108126	1
46	UNION, adapter	190451	190451	190451	1
47	UNION	188597	188597	188597	1

Heat Control Package

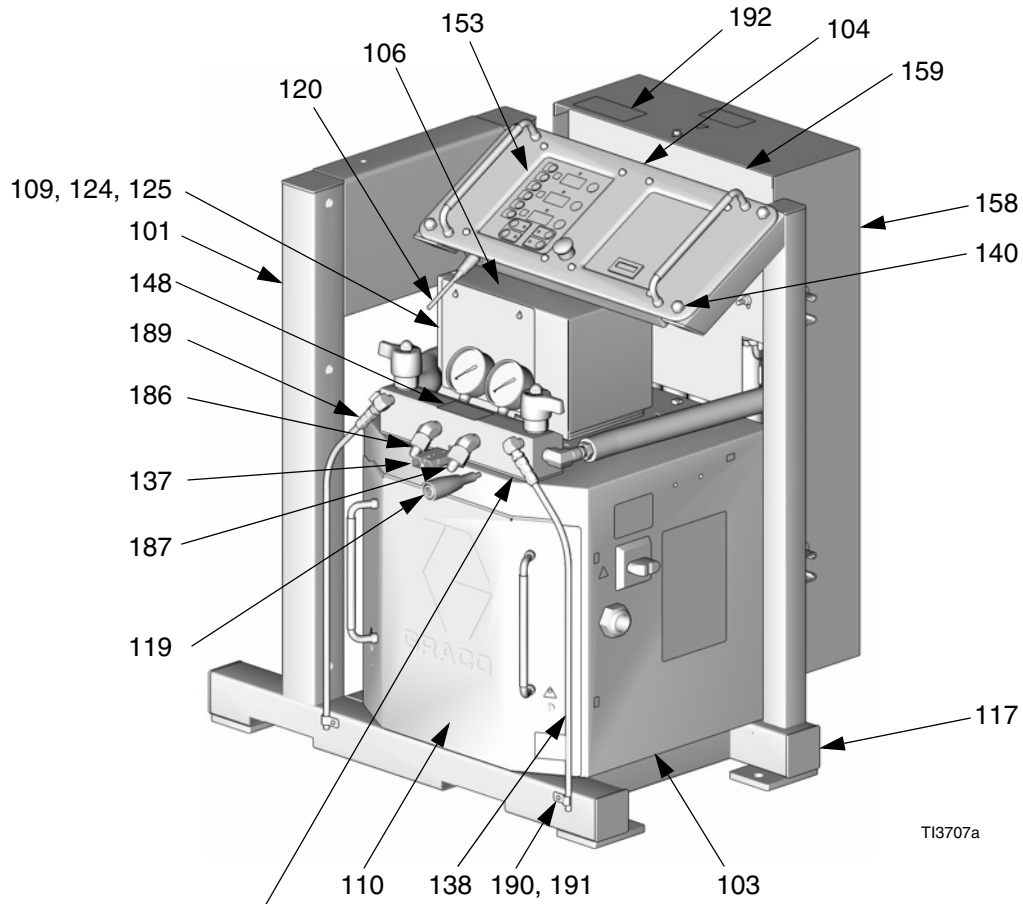

TI3707a

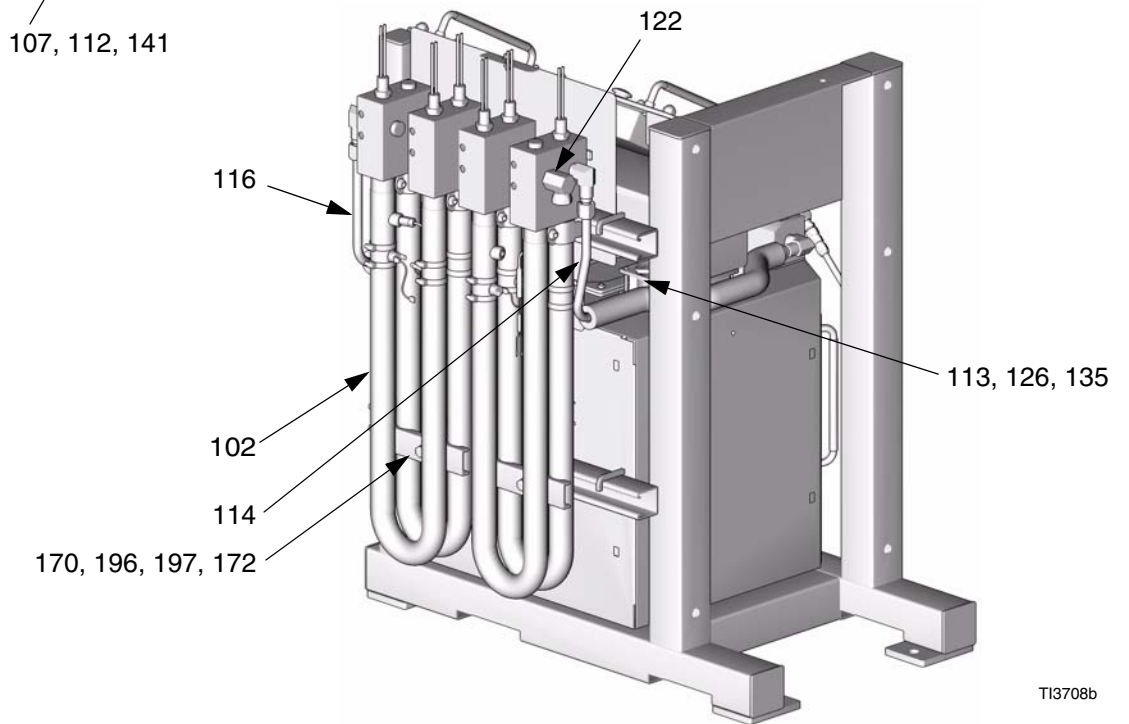

TI3708b

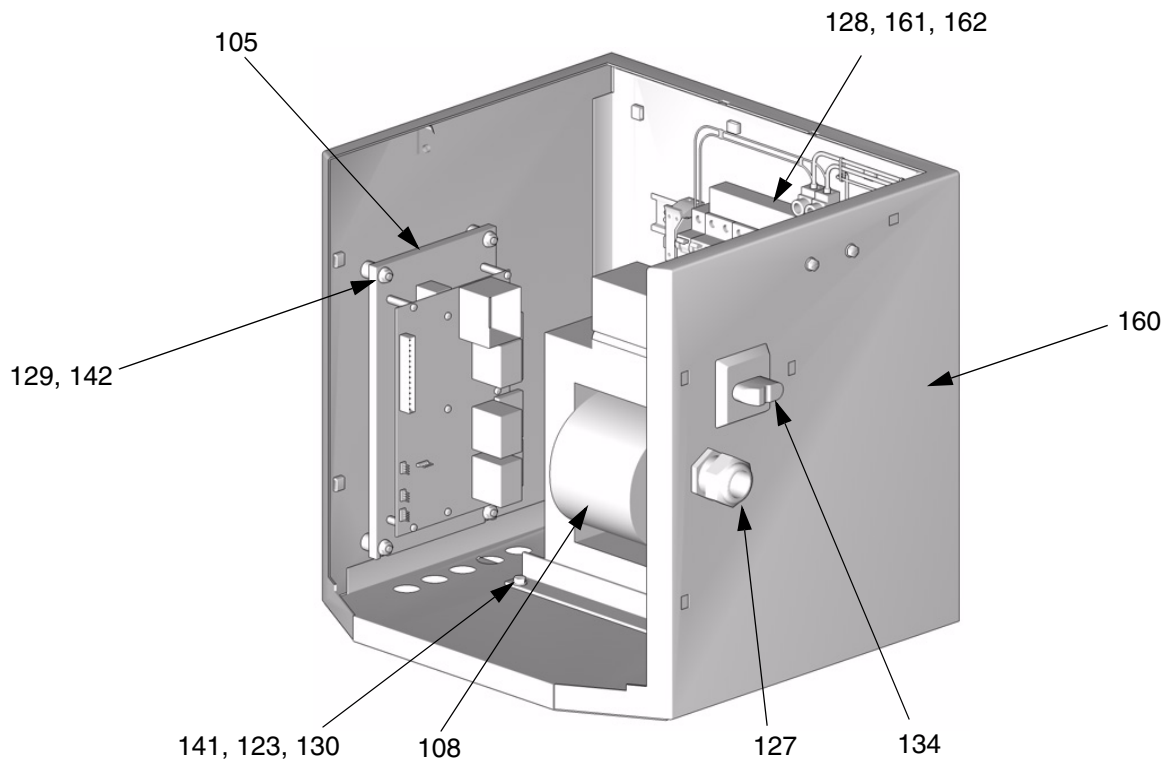

TI2606A

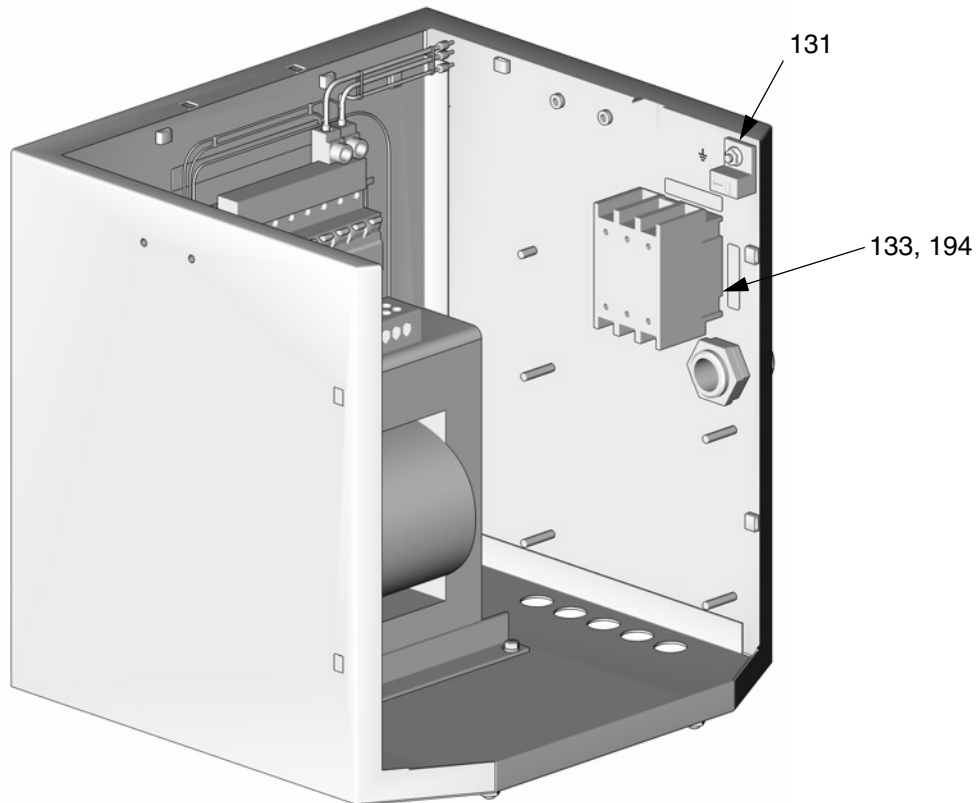

TI3705a

Heat Control Package

Use the following chart to find parts that vary by package. Find the ref. no. of part in left column, and package in top row. Intersection is correct part no.

Ref. No.	Description	Heat Control Package									Qty
		246364	246365	246607	246760	246761	246762	246763	246764	246765	
101	FRAME	245955	245955	245955	245955	245955	245955	245955	245955	245955	1
102	HEATER; pages 48, 49	245963 (qty: 2)	245975 (qty: 1)	245962 (qty: 1)	245975 (qty: 1)	245975 (qty: 1)	245962 (qty: 1)	245962 (qty: 1)	245963 (qty: 2)	245963 (qty: 2)	1 or 2
103	ENCLOSURE, electronics	15C220	15C220	15C220	15C220	15C220	15C220	15C220	15C220	15C220	1
104	DISPLAY; page 50	246043	246043	246043	246043	246043	246043	246043	246043	246043	1
105	CONTROL, temperature; page 51	245979	245979	245979	245979	245979	245979	245979	245979	245979	1
106	COVER, fan	15C223	15C223	15C223	15C223	15C223	15C223	15C223	15C223	15C223	1
107	MANIFOLD, fluid; page 52	246042	246042	246042	246042	246042	246042	246042	246042	246042	1
108	TRANSFORMER; see page 57	15B352	15B352	15B352	15B352	15B352	15B352	15B352	15B352	15B352	1
109	COVER, wire access	15B775	15B775	15B775	15B775	15B775	15B775	15B775	15B775	15B775	1
110	DOOR, cabinet	246976	246976	246976	246976	246976	246976	246976	246976	246976	1
111	SENSOR, fluid temperature	246079	246079	246079	246079	246079	246079	246079	246079	246079	1
112	GASKET, manifold	15B456	15B456	15B456	15B456	15B456	15B456	15B456	15B456	15B456	1
113	FAN	115834	115834	115834	115834	115834	115834	115834	115834	115834	1
114	TUBE, heater, component A	15B685	15B481	15B481	15B481	15B481	15B481	15B481	15B685	15B685	1
115	SCREW, machine; 8-32 x 0.345 in. (9 mm)	115492	115492	115492	115492	115492	115492	115492	115492	115492	2
116	TUBE, heater, component B	15B687	15B483	15B483	15B483	15B483	15B483	15B483	15B687	15B687	1
117	CAP, square	168422	168422	168422	168422	168422	168422	168422	168422	168422	6
118	CABLE, overtemperature; not shown, see electrical diagrams	15B374	15B374	15B374	15B374	15B374	15B374	15B374	15B374	15B374	1
119	CABLE, hose control	15B380	15B380	15B380	15B380	15B380	15B380	15B380	15B380	15B380	1
120	CABLE, display	15B383	15B383	15B383	15B383	15B383	15B383	15B383	15B383	15B383	1

Ref. No.	Description	Heat Control Package									Qty
		246364	246365	246607	246760	246761	246762	246763	246764	246765	
122	ELBOW, street; 1/2 npt (mxf)	158683	158683	158683	158683	158683	158683	158683	158683	158683	2
123	NUT, hex flange; 3/8-16	112958	112958	112958	112958	112958	112958	112958	112958	112958	4
124	BOOT, wire feed through	15B361	15B361	15B361	15B361	15B361	15B361	15B361	15B361	15B361	1
125	PLATE, cover, wire	15B510	15B510	15B510	15B510	15B510	15B510	15B510	15B510	15B510	1
126	GASKET, fan	15B360	15B360	15B360	15B360	15B360	15B360	15B360	15B360	15B360	1
127	STRAIN RELIEF	117682	117682	117682	117682	117682	117682	117682	117682	117682	1
128	MODULE, breaker; page 53	246092	246090	246090	246087	246096	246087	246096	246089	246098	1
129	SPACER	116149	116149	116149	116149	116149	116149	116149	116149	116149	4
130	SCREW, cap; 3/8-16 x 5/8 in. (16 mm)	100575	100575	100575	100575	100575	100575	100575	100575	100575	4
131	TERMINAL, ground	117666	117666	117666	117666	117666	117666	117666	117666	117666	1
132	SENSOR, current, hose; not shown, see electrical diagrams	15B388	15B388	15B388	15B388	15B388	15B388	15B388	15B388	15B388	1
133	SWITCH, disconnect	117564	117564	117564	117564	117564	117564	117564	117564	117564	1
134	SWITCH, main power	117545	117545	117545	117545	117545	117545	117545	117545	117545	1
135	SCREW, machine; 6-32 x 2 in. (51 mm)	117723	117723	117723	117723	117723	117723	117723	117723	117723	4
137	WIRE, hose	15B396	15B396	15B396	15B396	15B396	15B396	15B396	15B396	15B396	1
138	TUBE; 1/4 in. (6 mm) ID; 3/8 in. (16 mm) OD; 2 ft (1.2 m); PTFE	buy locally	buy locally	buy locally	buy locally	buy locally	buy locally	buy locally	buy locally	buy locally	1
140	NUT, cap; 3/8-16	117623	117623	117623	117623	117623	117623	117623	117623	117623	4
141	SCREW, cap; 1/4-20 x 3/4 in. (19 mm)	113796	113796	113796	113796	113796	113796	113796	113796	113796	7
142	NUT, hex flange; 1/4-20	115942	115942	115942	115942	115942	115942	115942	115942	115942	7
▲ 148	LABEL, caution	189285	189285	189285	189285	189285	189285	189285	189285	189285	3
153	SHIELD, membrane switch; pack of 10	15B593	15B593	15B593	15B593	15B593	15B593	15B593	15B593	15B593	1
158	COVER, heater, back	15B797	15B797	15B797	15B797	15B797	15B797	15B797	15B797	15B797	1
159	COVER, heater, front	15B798	15B798	15B798	15B798	15B798	15B798	15B798	15B798	15B798	1
▲ 160	LABEL, warning	15B679	15B679	15B679	15B679	15B679	15B679	15B679	15B679	15B679	1

Ref. No.	Description	Heat Control Package									Qty
		246364	246365	246607	246760	246761	246762	246763	246764	246765	
161	NUT, hex, keps; 10-24	113505	113505	113505	113505	113505	113505	113505	113505	113505	6
162	WASHER, plain; no. 10	112776	112776	112776	112776	112776	112776	112776	112776	112776	2
163	CONNECTOR, wire; not shown, see electrical diagrams	117722	117722	117722	117722	117722	117722	117722	117722	117722	4
170	BOLT; 3/8-16	516595 (qty: 4)	516595 (qty: 2)	516595 (qty: 2)	516595 (qty: 2)	516595 (qty: 2)	516595 (qty: 2)	516595 (qty: 2)	516595 (qty: 2)	516595 (qty: 4)	2 or 4
172	CLAMP, pipe, heater	15C733 (qty: 4)	15C733 (qty: 2)	15C733 (qty: 2)	15C733 (qty: 2)	15C733 (qty: 2)	15C733 (qty: 2)	15C733 (qty: 2)	15C733 (qty: 2)	15C733 (qty: 4)	2 or 4
179	FERRULE	112512	112512	112512	112512	112512	112512	112512	112512	112512	2
180	ELBOW; 1/2 npt x 1/2 in. (13 mm) OD tube	117532	117532	117532	117532	117532	117532	117532	117532	117532	2
182	CABLE, overtemperature, jumper	15B769 (qty: 4)	15B769 (qty: 2)	15B769 (qty: 2)	15B769 (qty: 2)	15B769 (qty: 2)	15B769 (qty: 2)	15B769 (qty: 2)	15B769 (qty: 2)	15B769 (qty: 4)	2 or 4
183	WASHER, lock; 1/4	100016	100016	100016	100016	100016	100016	100016	100016	100016	15
184	WASHER, plain; 3/16	100086	100086	100086	100086	100086	100086	100086	100086	100086	8
186	REDUCER; #5 x #8 JIC	117502	117502	117502	117502	117502	117502	117502	117502	117502	1
187	REDUCER; #6 x #10 JIC	117677	117677	117677	117677	117677	117677	117677	117677	117677	1
189	COUPLING, hose; 1/4 npsm(f)	205447	205447	205447	205447	205447	205447	205447	205447	205447	2
190	BRACKET, holding	15C447	15C447	15C447	15C447	15C447	15C447	15C447	15C447	15C447	2
191	SCREW, machine; 5-40 x 1/2 in. (13 mm)	100974	100974	100974	100974	100974	100974	100974	100974	100974	2
192	LABEL, diagnostic codes	15C477	15C477	15C477	15C477	15C477	15C477	15C477	15C477	15C477	1
194	SWITCH, added pole; 380V					117553		117553		117553	1
195 ▲	LABEL, warning;	171001	171001	171001	171001	171001	171001	171001	171001	171001	1
196	WASHER, lock; 3/8 in.	100133 (qty: 4)	100133 (qty: 2)	100133 (qty: 2)	100133 (qty: 2)	100133 (qty: 2)	100133 (qty: 2)	100133 (qty: 2)	100133 (qty: 2)	100133 (qty: 4)	2 or 4
197	NUT; 3/8-16	118446 (qty: 4)	118446 (qty: 2)	118446 (qty: 2)	118446 (qty: 2)	118446 (qty: 2)	118446 (qty: 2)	118446 (qty: 2)	118446 (qty: 2)	118446 (qty: 4)	2 or 4

▲ Replacement Warning labels, signs, tags, and cards are available at no cost.

Fluid Heater

245962 10.2 kW Heater, for A-25 and A-XP2 Reactors, and HT-10.2 Heat Packages

* Ref. No. 182 not included with heater.
Order separately, see page 47.

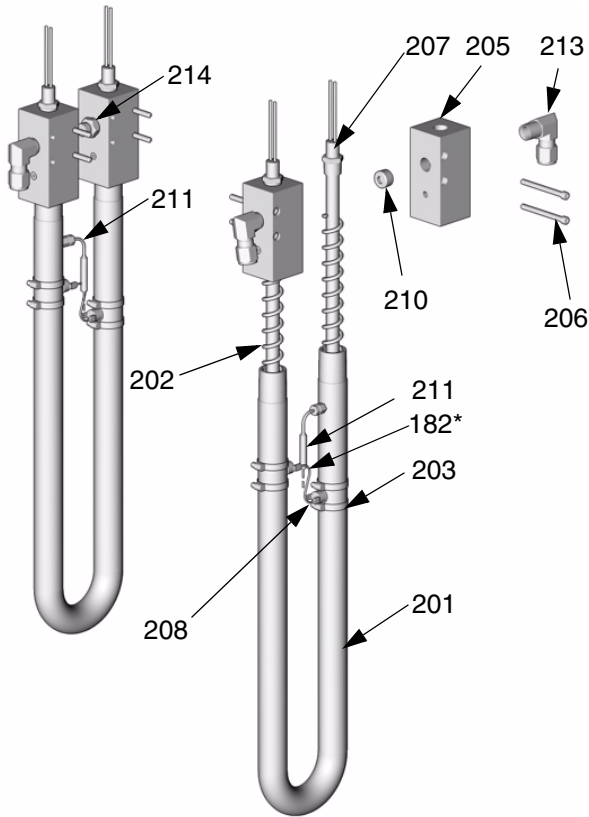

TI2512b

245963 7.65 kW Heater, for A-50, H-50, and H-XP3 Reactors, and HT-15.3 Heat Packages (2 required)

* Ref. No. 182 not included with heater.
Order separately, see page 47.

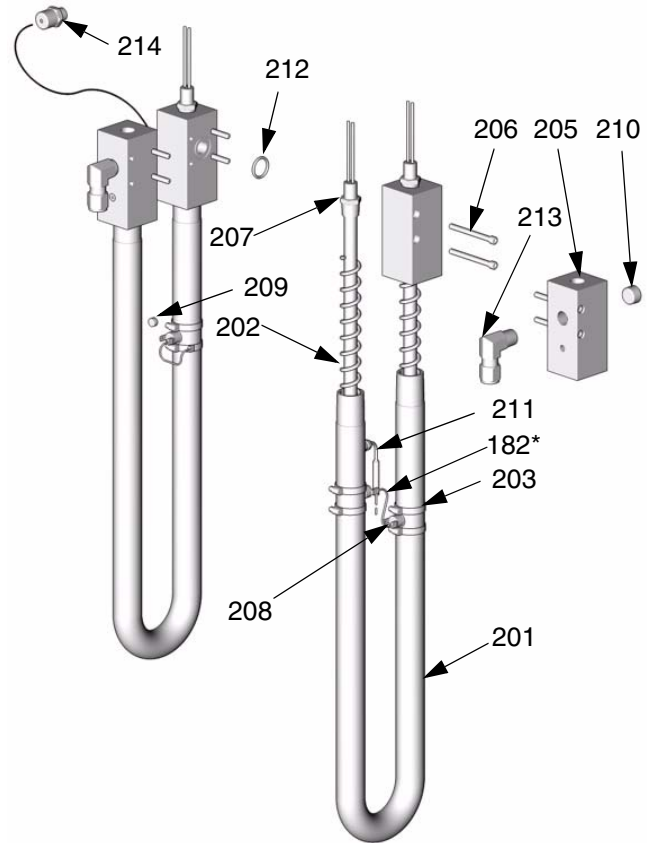

TI2578b

Ref. No.	Part No.	Description	Qty
201	15B134	HOUSING	2
202	15B135	MIXER	4
203	118426	CLAMP	8
205	15B132	MANIFOLD	4
206	107218	SCREW	8
207	15B138	HEATER, immersion; 2550 W; 230v	4
208	15B137	SWITCH, overtemperature	4
210	100361	PLUG	4
211	117484	SENSOR, temperature	2
213	117532	ELBOW; 1/2 npt x 1/2 in. (13 mm) OD tube	4
214	248187	RUPTURE DISK KIT; see 309969	2
213	117532	ELBOW; 1/2 npt x 1/2 in. (13 mm) OD tube	2
214	248187	RUPTURE DISK KIT; see 309969	1

Ref. No.	Part No.	Description	Qty
201	15B134	HOUSING	2
202	15B135	MIXER	3
203	118426	CLAMP	6
204	15B133	CROSSOVER	2
205	15B132	MANIFOLD	2
206	107218	SCREW	8
207	15B138	HEATER, immersion; 2550 W; 230v	3
208	15B137	SWITCH, overtemperature	3
209	100139	PLUG	1
210	100361	PLUG	2
211	117484	SENSOR, temperature	1
212	117466	O-RING	1
213	117532	ELBOW; 1/2 npt x 1/2 in. (13 mm) OD tube	2
214	248187	RUPTURE DISK KIT; see 309969	1

245975 6 kW Heater, for HT-6.0 Heat Packages

* Ref. No. 182 not included with heater.
Order separately, see page 47.

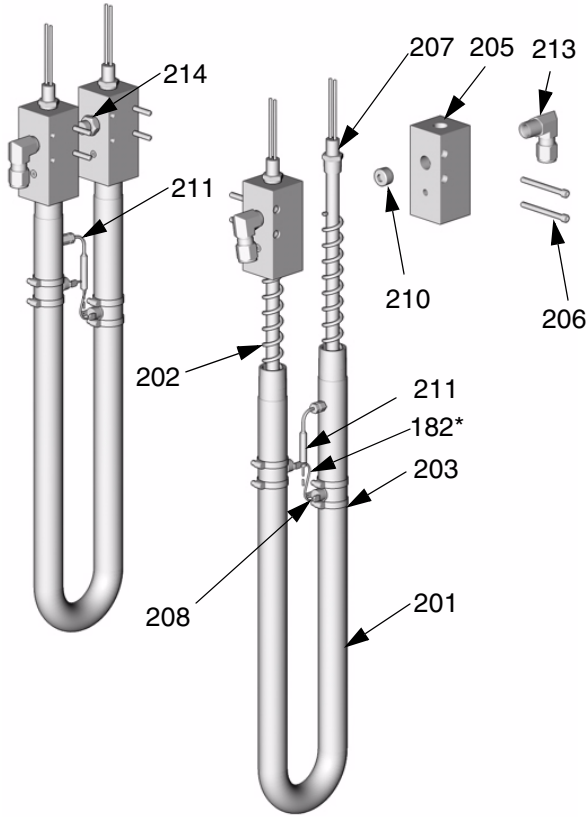

Ref. No.	Part No.	Description	Qty
201	15B134	HOUSING	2
202	15B135	MIXER	4
203	118426	CLAMP	8
205	15B132	MANIFOLD	4
206	107218	SCREW	8
207	15B140	HEATER, immersion; 1500 W; 230v	4
208	15B137	SWITCH, overtemperature	4
210	100361	PLUG	2
211	117484	SENSOR, temperature	2
213	117532	ELBOW; 1/2 npt x 1/2 in. (13 mm) OD tube	4
214	248187	RUPTURE DISK KIT; see 309969	2

TI2512b

Display

246043 Display

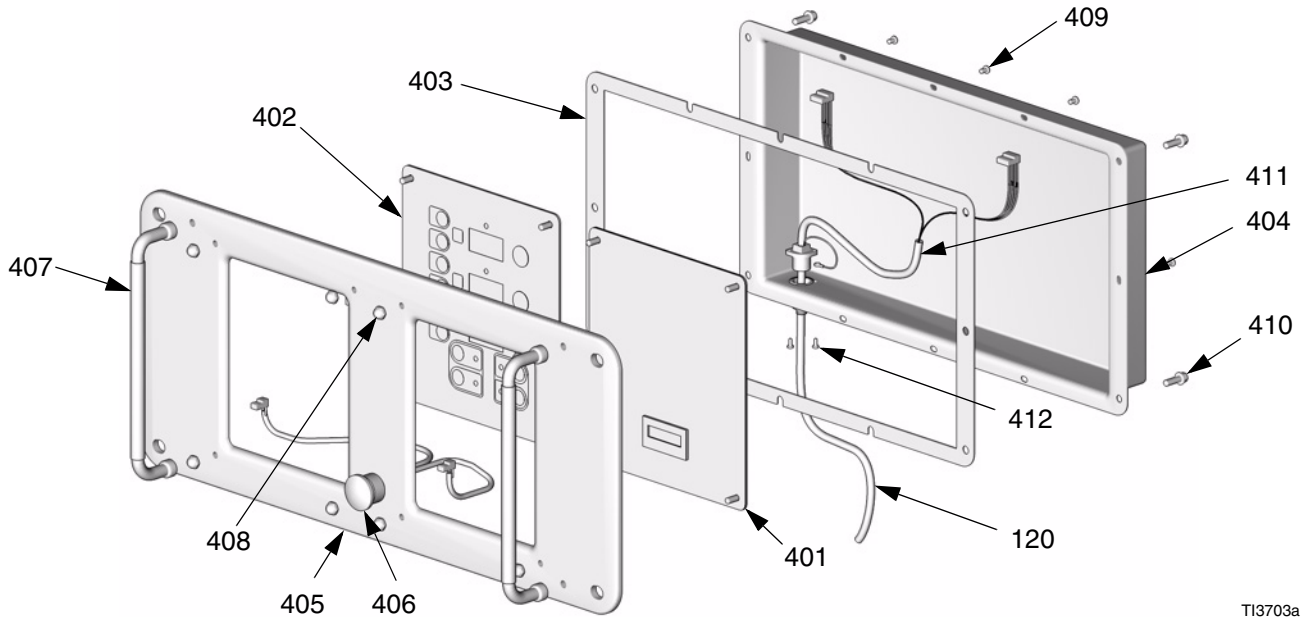

TI3703a

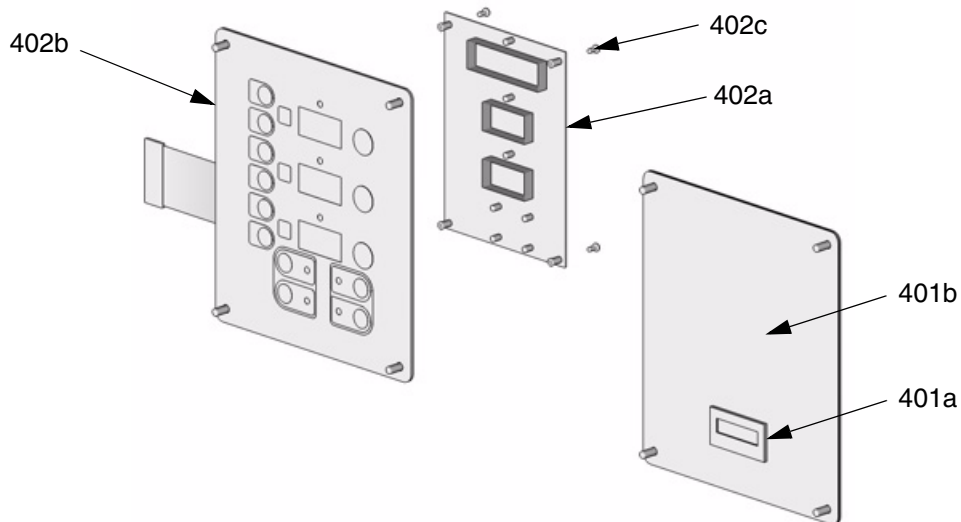

TI3702a

Ref. No.	Part No.	Description	Qty	Ref. No.	Part No.	Description	Qty
401	246044	DISPLAY, counter; includes 401a-401b	1	405	15B291	PLATE	1
401a	117830	. COUNTER, digital	1	406	246287	HARNESS, wire, red stop button	1
401b	15B365	. LABEL	1	407	117499	HANDLE	2
402	245977	DISPLAY, temperature; includes 402a-402c	1	408	117523	NUT, cap; 10-24	8
402a	246130	. BOARD, circuit	1	409	111008	SCREW, tapping, 6-32; 1/4 in. (6 mm)	8
402b	246479	. SWITCH, membrane	1	410	111393	SCREW, machine, pan-hd; M5 x 0.8; 16 mm	4
402c	112324	. SCREW	4	411	15B386	CABLE, display	1
403	15B293	GASKET	1	412	195853	SCREW, machine; M2.5 x 6	2
404	15B292	COVER	1	414	118115	CONNECTOR, cable; 5-pin; 24 AWG	1

Temperature Control

245979 Temperature Control

 Apply 110009 thermal heatsink compound to mating surfaces.

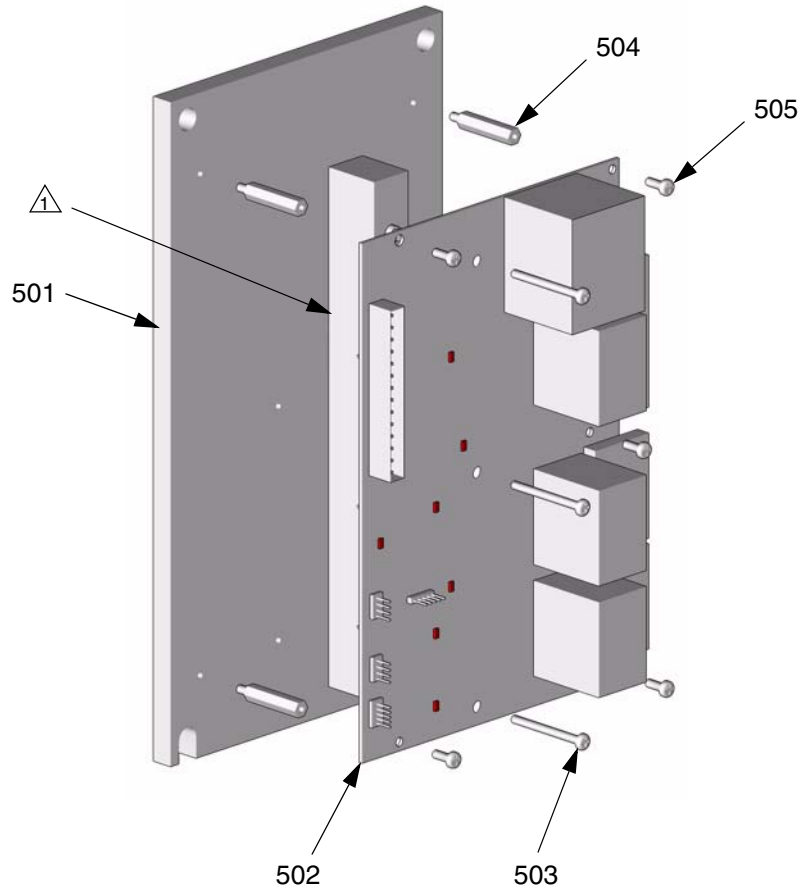

T12575A-1

Ref. No.	Part No.	Description	Qty
501	15B779	HEAT SINK	1
502	246194	BOARD, temperature control	1
503	117683	SCREW, 6-32 x 1-1/2 in. (38 mm)	2
504	117526	SPACER	5
505	104590	SCREW, machine; 6-32 x 3/8 in. (10 mm)	5

Fluid Manifold

246042 Fluid Manifold

- ① Apply 113500 thread lock (blue).
- ② Torque to 355-395 in-lb (40.1-44.6 N•m).
- ③ Apply PTFE tape or thread sealant to tapered threads.
- ④ Torque to 175-195 in-lb (19.8-22.0 N•m).
- ⑤ Lubricate ends of spring when assembling.
- ⑥ Assemble valves (702) and handles (709) with handles facing away from each other.

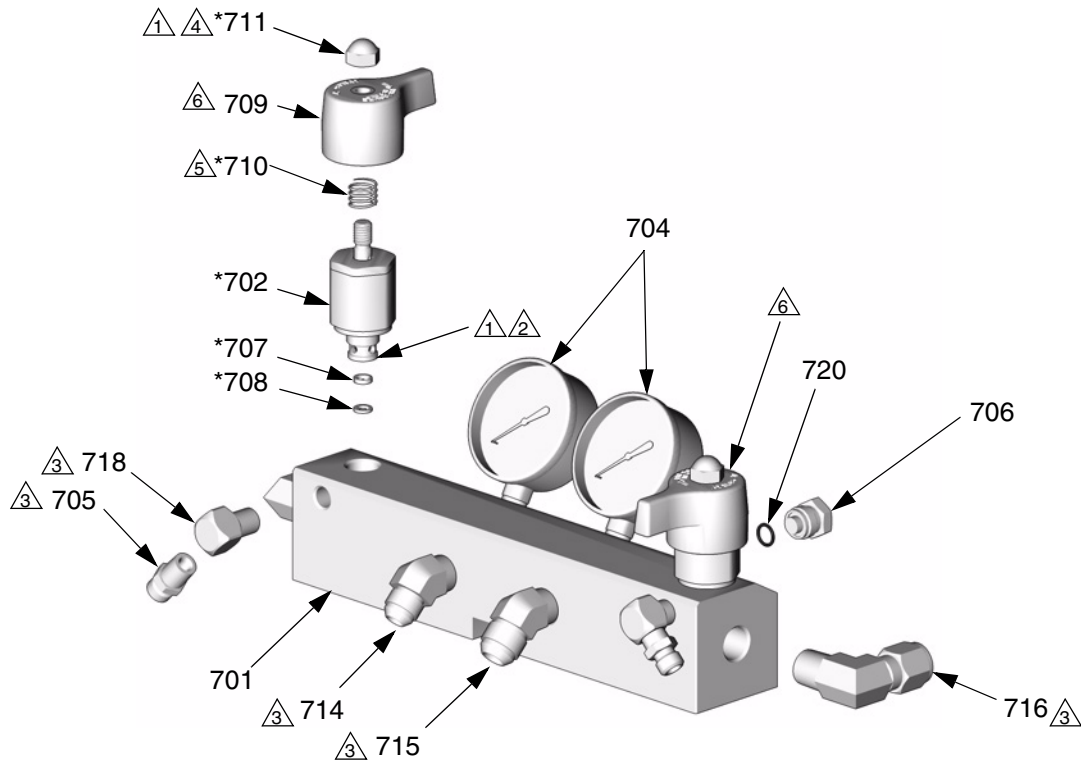

TI3706b

Ref. No.	Part No.	Description	Qty	Ref. No.	Part No.	Description	Qty
701	15B332	MANIFOLD; aluminum	1	711*	117623	NUT, cap; 3/8-16	2
702*	246161	VALVE, pressure relief/spray	2	714	117556	ELBOW, 45°; #8 JIC x 1/2 npt	1
704	102814	GAUGE; 5000 psi (35 MPa, 350 bar)	2	715	117557	ELBOW, 45°; #10 JIC x 1/2 npt	1
705	162453	NIPPLE; 1/4 npt x 1/4 npsm	2	716	117532	ELBOW; 1/2 npt(m) x 1/2 in. (13 mm) OD tube	2
706	198241	PLUG, pressure; 11/16-24 unef	2	718	100840	ELBOW, street; 1/4 npsm x 1/4 npt	2
707*	193709	SEAT, valve; carbide	2	720	111457	O-RING; PTFE	2
708*	193710	SEAL, seat; nylon	2				
709*	15B287	HANDLE, valve	2				
710*	114708	SPRING	2				

* Included in Repair Kit 245103 (purchase separately).

Circuit Breaker Modules

230V, 3 Phase Circuit Breaker Modules

 For wiring and cable connections, refer to electrical diagrams supplied. See page 56 for parts list.

Part No. 246087 (A-25, A-XP2)

Part No. 246089 (A-50)

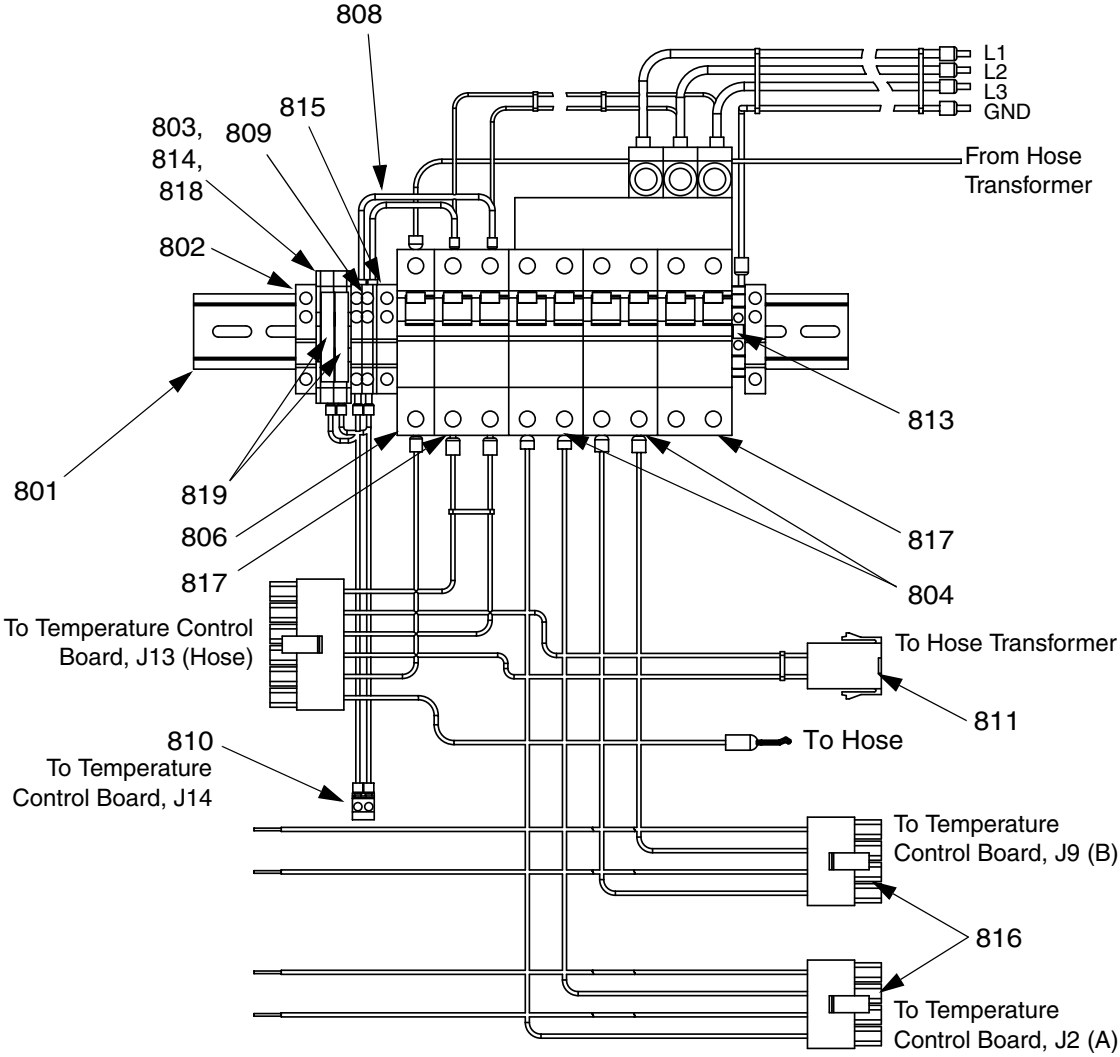

230V, 1 Phase Circuit Breaker Modules

 For wiring and cable connections, refer to electrical diagrams supplied. See page 56 for parts list.

Part No. 246090 (A-25, A-XP2)

Part No. 246092 (A-50)

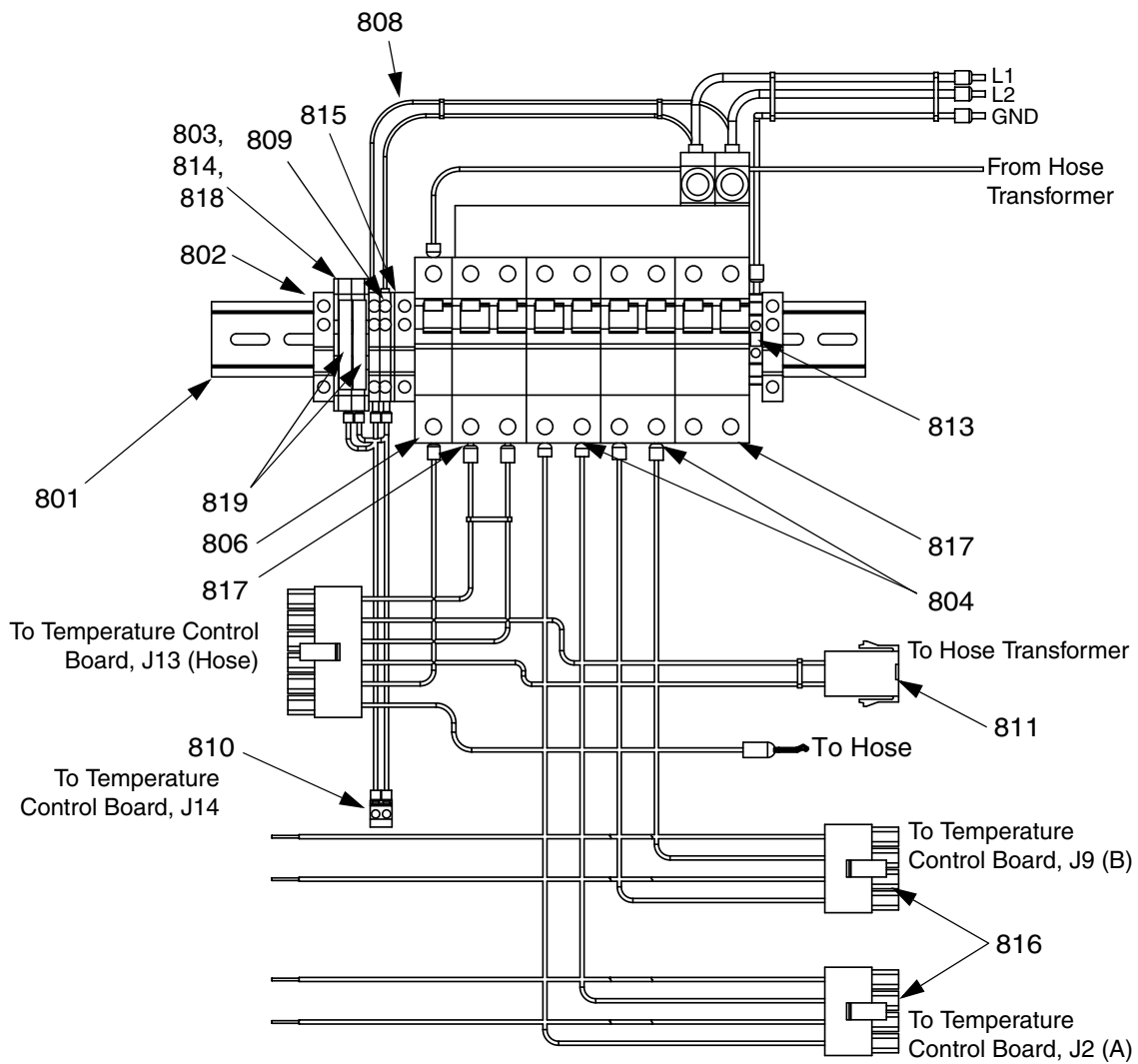

380V, 3 Phase Circuit Breaker Modules

 For wiring and cable connections, refer to electrical diagrams supplied. See page 56 for parts list.

Part No. 246096 (A-25, A-XP2)

Part No. 246098 (A-50)

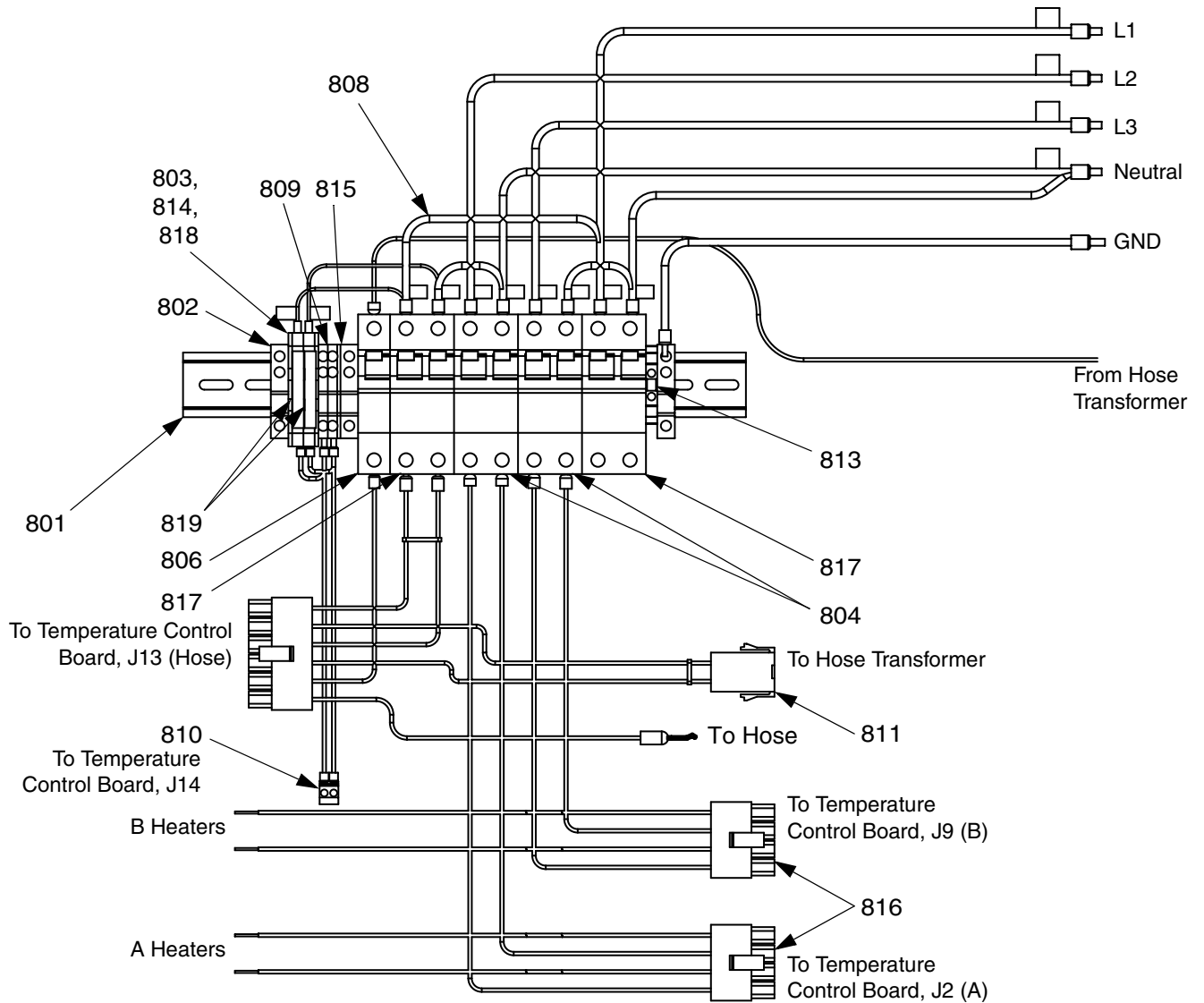

Circuit Breaker Modules Parts List

Ref. No.	Description	Breaker Modules						Qty
		246087 230V, 3 Ø	246089 230V, 3 Ø	246090 230V, 1 Ø	246092 230V, 1 Ø	246096 380V, 3 Ø	246098 380V, 3 Ø	
801	RAIL, mounting	buy locally	buy locally	buy locally	buy locally	buy locally	buy locally	1
802	CLAMP, end	112446	112446	112446	112446	112446	112446	3
803	TERMINAL, base, fuse plug	117798	117798	117798	117798	117798	117798	2
804	BREAKER, dual; 25A	117591		117591		117591		2
	BREAKER, dual; 40A		117505		117505		117505	2
805	BAR, power buss, 3 phase	117805	117805					1
	BAR, power buss, 1 phase			117678	117678			1
806	BREAKER, single; 50A	117503	117503	117503	117503	117503	117503	1
807	CONNECTOR, power lug	117679	117679					3
	CONNECTOR, power lug			117679	117679			2
808	CABLE, harness; 230V, 3 phase	15B387	15B387					1
	CABLE, harness; 230V, 1 phase			117674	117674			1
	CABLE, harness; 380V, 3 phase					15B377	15B377	1
809	TERMINAL, block	117796	117796	117796	117796	117796	117796	2
810	CABLE, harness, power temp	15B375	15B375	15B375	15B375	15B375	15B375	1
811	CABLE, hose, heat	15B378	15B378	15B378	15B378	15B378	15B378	1
813	BLOCK, terminal ground	112443	112443	112443	112443	112443	112443	1
814	FUSE, fan; 5 x 20 mm Bussman GDA-2A or equivalent	115216	115216	115216	115216	115216	115216	2
815	TERMINAL, end cover	117807	117807	117807	117807	117807	117807	1
816	CABLE, harness, heat A/B	15B376	15B376	15B376	15B376	15B376	15B376	2
817	BREAKER, dual; 20A	117711	117711	117711	117711	117711	117711	2
818	TERMINAL, end cover	117797	117797	117797	117797	117797	117797	1
819	FUSE, plug	117799	117799	117799	117799	117799	117799	2

Transformer

Part No. 15B352 Transformer

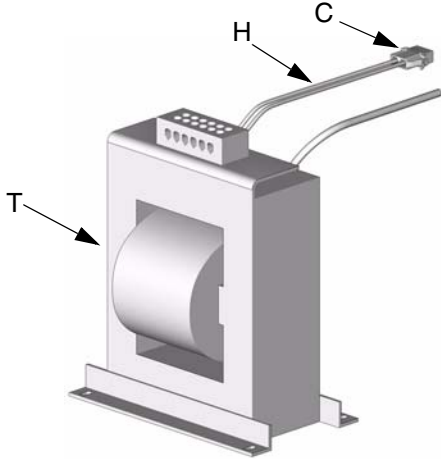

TI3470b

Technical Data

Category	Data
Maximum Fluid Working Pressure	Model A-25: 1920 psi (13 MPa, 130 bar) Models A-50 and H-50: 2000 psi (14 MPa, 140 bar) Models A-XP2 2:1: 2050 psi (14.1 MPa, 141 bar) Models A-XP2 and H-XP3: 3000 psi (20.7 MPa, 207 bar)
Maximum Input Pressure to Motor	Models A-25, A-XP2, and A-XP2 2:1: 120 psi (0.82 MPa, 8.2 bar) air Model A-50: 75 psi (0.5 MPa, 5 bar) air Models H-50 and H-XP3: 1200 psi (8.4 MPa, 84 bar) oil
Pressure Ratio	
Fluid:Air	Model A-25: 16:1 Model A-XP2 2:1: 17.1:1 Model A-XP2: 25:1 Model A-50: 26:1
Fluid:Oil	Model H-50: 1.65:1 Model H-XP3: 2.76:1
Air Inlet	Models A-25, A-XP2, and A-XP2 2:1: 1/2 npsm(f) Model A-50: 3/4 npsm(f)
Recommended Air Supply Hose Size	Models A-25, A-XP2, and A-XP2 2:1: 1/2 in. (13 mm) ID minimum Model A-50: 3/4 in. (19 mm) ID minimum
Air Consumption	Model A-25: 40 scfm at 120 psi (0.82 MPa, 8.2 bar), 1.6 gpm (6.1 lpm) Model A-XP2: 40 scfm at 120 psi (0.82 MPa, 8.2 bar), 1.0 gpm (3.8 lpm) Model A-XP2 2:1: 40 scfm at 120 psi (0.82 MPa, 8.2 bar), 1.5 gpm (5.7 lpm) Model A-50: 80 scfm at 75 psi (0.5 MPa, 5 bar), 5.0 gpm (19 lpm); 35 scfm at 75 psi (0.5 MPa, 5 bar), 2.0 gpm (7.6 lpm)
Hydraulic Supply Inlet	Models H-50 and H-XP3: 3/4 npt(f)
Hydraulic Return Outlet	Models H-50 and H-XP3: 1 in. npt(f)
Recommended Hydraulic Hose Size	Supply Hose: 3/4 in. (19 mm) ID minimum Return Hose: 1 in. (25 mm) ID minimum
Maximum Hydraulic Oil Flow	Models H-50 and H-XP3: 10 gpm (3.8 lpm), 50 cycles/min
Hydraulic Oil Consumption	Models H-50 and H-XP3: 1.0 gpm (38 lpm) per 5 cycles
Fluid Inlets	Models A-25, A-XP2, A-XP2 2:1, and H-XP3: 3/4 npt(f) Models A-50 and H-50: 1" npt(f) Model HT heat packages: 1/2 npt(f) on heater inlet blocks
Fluid Outlets	Component A (ISO): #8 JIC (3/4-16 unf), with #5 JIC adapter Component B (RES): #10 JIC (7/8-14 unf), with #6 JIC adapter
Fluid Circulation Ports	1/4 npsm(m), with plastic tubing, 250 psi (1.75 MPa, 17.5 bar) maximum
Maximum Fluid Temperature	190°F (88°C)

Category	Data
Maximum Output (10 weight oil at ambient temperature)	Model A-25: 20 lb/min (9 kg/min) at 60 cycles/min Models A-50 and H-50: 50 lb/min (22.5 kg/min) at 50 cycles/min Model A-XP2: 1 gpm (3.8 liter/min) at 60 cycles/min Model A-XP2 2:1: 1.5 gpm (5.7 liter/min) at 60 cycles/min Model H-XP3: 3.6 gpm (13.7 liter/min) at 50 cycles/min
Output per Cycle (A and B)	Model A-25: 0.031 gal. (0.117 liter) Models A-50 and H-50: 0.114 gal. (0.431 liter) Model A-XP2: 0.0193 gal. (.073 liter) Model A-XP2 2:1: 0.02895 gal. (0.110 liter) Model H-XP3: 0.072 gal. (0.274 liter)
Line Voltage Requirement	230V 1 phase and 230V 3 phase units: 195-264 Vac, 50/60 Hz 380V 3 phase units: 338-457 Vac, 50/60 Hz
Amperage Requirement	See page 4.
Heater Power (A and B heaters, no hose)	Model HT-6.0: 6000 Watts Models A-25, A-XP2, A-XP2 2:, and HT-10.2: 10200 Watts Models A-50, H-50, H-XP3, and HT-15.3: 15300 Watts
Sound Power, per ISO 9614-2	Model A-25: 94.7 dB(A) at 1000 psi (7 MPa, 70 bar), 3.0 gpm (11.4 lpm), 15 cpm Model A-50: 86.5 dB(A) at 1000 psi (7 MPa, 70 bar), 3.0 gpm (11.4 lpm), 15 cpm Model A-XP2: 94.7 dB(A) at 2000 psi (14 MPa, 140 bar), 0.5 gpm (1.9 lpm), 15 cpm Model A-XP2 2:1: 94.7 dB(A) at 1370 psi (9.4MPa, 94 bar), 0.75 gpm (2.8 lpm), 15 cpm Model H-50: 88 dB(A) at 1000 psi (7 MPa, 70 bar), 3.0 gpm (11.4 lpm), 20 cpm Model H-XP3: 103 dB(A) at 2000 psi (14 MPa, 140 bar), 0.5 gpm (1.9 lpm), 25 cpm
Sound Pressure, 1 m from equipment	Model A-25: 81 dB(A) at 1000 psi (7 MPa, 70 bar), 3.0 gpm (11.4 lpm), 15 cpm Model A-50: 78.8 dB(A) at 1000 psi (7 MPa, 70 bar), 3.0 gpm (11.4 lpm), 15 cpm Model A-XP2: 81 dB(A) at 2000 psi (14 MPa, 140 bar), 0.5 gpm (1.9 lpm), 15 cpm Model A-XP2 2:1: 81 dB(A) at 1370psi (9.4 MPa, 94 bar), 0.75 gpm (2.8 lpm), 15 cpm Model H-50: 78 dB(A) at 1000 psi (7 MPa, 70 bar), 3.0 gpm (11.4 lpm), 20 cpm Model H-XP3: 88 dB(A) at 2000 psi (14 MPa, 140 bar), 0.5 gpm (1.9 lpm), 25 cpm
Weight	Models A-25 and A-XP2: 400 lb (180 kg) Models A-XP2 2:1: 420 lb (190 kg) Model A-50: 480 lb (216 kg) Model H-50: 475 lb (214 kg) Model H-XP3: 485 lb (218 kg) Models HT-6.0, HT-10.2, and HT-15.3: 333 lb (150 kg)
Wetted Parts	Aluminum, stainless steel, zinc-plated carbon steel, brass, carbide, chrome, chemically resistant o-rings, PTFE, ultra-high molecular weight polyethylene

Loctite® is a registered trademark of the Loctite Corporation.

Graco Standard Warranty

Graco warrants all equipment referenced in this document which is manufactured by Graco and bearing its name to be free from defects in material and workmanship on the date of sale to the original purchaser for use. With the exception of any special, extended, or limited warranty published by Graco, Graco will, for a period of twelve months from the date of sale, repair or replace any part of the equipment determined by Graco to be defective. This warranty applies only when the equipment is installed, operated and maintained in accordance with Graco's written recommendations.

This warranty does not cover, and Graco shall not be liable for general wear and tear, or any malfunction, damage or wear caused by faulty installation, misapplication, abrasion, corrosion, inadequate or improper maintenance, negligence, accident, tampering, or substitution of non-Graco component parts. Nor shall Graco be liable for malfunction, damage or wear caused by the incompatibility of Graco equipment with structures, accessories, equipment or materials not supplied by Graco, or the improper design, manufacture, installation, operation or maintenance of structures, accessories, equipment or materials not supplied by Graco.

This warranty is conditioned upon the prepaid return of the equipment claimed to be defective to an authorized Graco distributor for verification of the claimed defect. If the claimed defect is verified, Graco will repair or replace free of charge any defective parts. The equipment will be returned to the original purchaser transportation prepaid. If inspection of the equipment does not disclose any defect in material or workmanship, repairs will be made at a reasonable charge, which charges may include the costs of parts, labor, and transportation.

THIS WARRANTY IS EXCLUSIVE, AND IS IN LIEU OF ANY OTHER WARRANTIES, EXPRESS OR IMPLIED, INCLUDING BUT NOT LIMITED TO WARRANTY OF MERCHANTABILITY OR WARRANTY OF FITNESS FOR A PARTICULAR PURPOSE.

Graco's sole obligation and buyer's sole remedy for any breach of warranty shall be as set forth above. The buyer agrees that no other remedy (including, but not limited to, incidental or consequential damages for lost profits, lost sales, injury to person or property, or any other incidental or consequential loss) shall be available. Any action for breach of warranty must be brought within two (2) years of the date of sale.

GRACO MAKES NO WARRANTY, AND DISCLAIMS ALL IMPLIED WARRANTIES OF MERCHANTABILITY AND FITNESS FOR A PARTICULAR PURPOSE, IN CONNECTION WITH ACCESSORIES, EQUIPMENT, MATERIALS OR COMPONENTS SOLD BUT NOT MANUFACTURED BY GRACO. These items sold, but not manufactured by Graco (such as electric motors, switches, hose, etc.), are subject to the warranty, if any, of their manufacturer. Graco will provide purchaser with reasonable assistance in making any claim for breach of these warranties.

In no event will Graco be liable for indirect, incidental, special or consequential damages resulting from Graco supplying equipment hereunder, or the furnishing, performance, or use of any products or other goods sold hereto, whether due to a breach of contract, breach of warranty, the negligence of Graco, or otherwise.

FOR GRACO CANADA CUSTOMERS

The Parties acknowledge that they have required that the present document, as well as all documents, notices and legal proceedings entered into, given or instituted pursuant hereto or relating directly or indirectly hereto, be drawn up in English. Les parties reconnaissent avoir convenu que la rédaction du présente document sera en Anglais, ainsi que tous documents, avis et procédures judiciaires exécutés, donnés ou intentés, à la suite de ou en rapport, directement ou indirectement, avec les procédures concernées.

Graco Information

TO PLACE AN ORDER, contact your Graco distributor, or call this number to identify the distributor closest to you:

1-800-328-0211 Toll Free

612-623-6921

612-378-3505 Fax

*All written and visual data contained in this document reflects the latest product information available at the time of publication.
Graco reserves the right to make changes at any time without notice.*

MM 309813

Graco Headquarters: Minneapolis

International Offices: Belgium, China, Japan, Korea

GRACO INC. P.O. BOX 1441 MINNEAPOLIS, MN 55440-1441

www.graco.com
309813F 6/2006