

Dura-Flo™ Pumps

311828 rev.A

Stainless Steel Pumps with Severe-Duty Rod and Cylinder



Important Safety Instructions

Read all warnings and instructions in this manual.
Save these instructions.

See pages 3-5 for model information, including maximum working pressure.

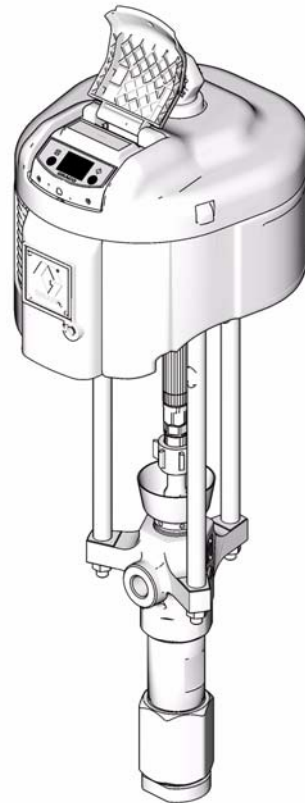

T18357a

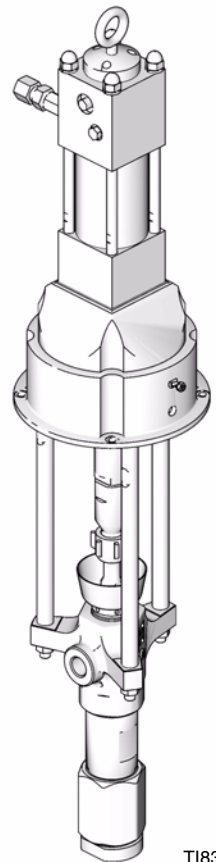

T18358a

PROVEN QUALITY. LEADING TECHNOLOGY.

Contents

| | | | |
|--|-----------|---|-----------|
| Models | 3 | Maintenance | 14 |
| Dura-Flo Pumps with NXT™ Air Motors Part No. Matrix | 3 | Preventive Maintenance Schedule | 14 |
| Dura-Flo Pumps with NXT™ Air Motors Part Nos. | 3 | Wet-Cups | 14 |
| Dura-Flo Pumps with NXT™ Air Motors Part Nos. (continued) | 4 | Flushing | 14 |
| Dura-Flo Pumps with NXT™ Air Motors Part Nos. (continued) | 5 | Corrosion Protection | 14 |
| Dura-Flo Pumps with Viscount® Hydraulic Motors | 5 | Hydraulic Systems | 14 |
| Warnings | 6 | Troubleshooting | 15 |
| Installation | 8 | Repair | 16 |
| Grounding | 8 | Required Tools | 16 |
| Flush Before Using Equipment | 8 | Disconnect the Lower | 16 |
| Mounting Accessories | 8 | Reconnect the Lower | 16 |
| Hoses | 8 | Parts | 18 |
| Air Line Accessories | 9 | Dura-Flo Pumps with NXT Air Motors | 18 |
| Hydraulic Line Accessories | 9 | Dura-Flo Pumps with Viscount Hydraulic Motors | 20 |
| Fluid Line Accessories | 9 | Dimensions | 22 |
| Operation | 12 | Mounting Hole Layouts | 23 |
| Pressure Relief Procedure | 12 | Technical Data | 24 |
| Trigger Lock | 12 | Graco Standard Warranty | 30 |
| Startup | 13 | Graco Information | 30 |
| Shutdown | 13 | | |

Models

Dura-Flo Pumps with NXT™ Air Motors Part No. Matrix

Check your pump's identification plate (ID) for the 6-digit part number of your pump. Use the following matrix to define the construction of your pump, based on the six digits. For example, Pump Part No. **P 1 6 M S E** represents the pump (**P**), pressure ratio (**1 6** :1), low noise exhaust motor with DataTrak™ (**M**), stainless steel construction (**S**), and 4 leather/1 ptfе packing configuration (**E**). To order replacement parts, see **Parts** section starting on page 18. The digits in the matrix do not correspond to the Ref. Nos. in the Parts drawings and lists.

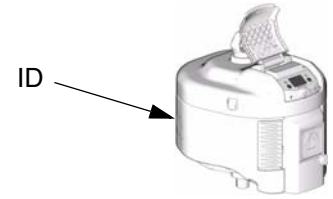

| P | 1 6 | M | | | S | | E | |
|---------------------|-------------------------------|---------------------|----------------------|----------|--------------------|-----------------|--------------------|------------------|
| First Digit | Second and Third Digit | Fourth Digit | | | Fifth Digit | | Sixth Digit | |
| | Pressure Ratio (xx:1) | Exhaust | Communication | | Material | | Packings | |
| P (pumps) | 16 | D | De-icing | none | S | Stainless Steel | E | 4 leather/1 ptfе |
| | 21 | E | De-icing | DataTrak | | | H | ptfе/leather |
| | 24 | L | Low Noise | none | | | | |
| | 25 | M | Low Noise | DataTrak | | | | |
| | 30 | | | | | | | |
| | 31 | | | | | | | |
| | 40 | | | | | | | |
| | 45 | | | | | | | |
| | 46 | | | | | | | |

Dura-Flo Pumps with NXT™ Air Motors Part Nos.

| Pump Part No., Series | Lower Part No. | Lower Model, Packings | Air Motor Part No. | Ratio | Maximum Working Pressure MPa, bar (psi) | Maximum Air Input Pressure MPa, bar (psi) |
|------------------------------|-----------------------|---|---------------------------|--------------|--|--|
| P16DSE, A | 247192 | Dura-Flo 1200 (290 cc), 4 leather/1 PTFE | N22DN0 | 16:1 | 10.5, 105 (1520) | 0.7, 7.0 (100) |
| P16ESE, A | 247192 | Dura-Flo 1200 (290 cc), 4 leather/1 PTFE | N22DT0 | 16:1 | 10.5, 105 (1520) | 0.7, 7.0 (100) |
| P16LSE, A | 247192 | Dura-Flo 1200 (290 cc), 4 leather/1 PTFE | N22LN0 | 16:1 | 10.5, 105 (1520) | 0.7, 7.0 (100) |
| P16MSE, A | 247192 | Dura-Flo 1200 (290 cc), 4 leather/1 PTFE | N22LT0 | 16:1 | 10.5, 105 (1520) | 0.7, 7.0 (100) |

Dura-Flo Pumps with NXT™ Air Motors Part Nos. (continued)

| Pump Part No., Series | Lower Part No. | Lower Model, Packings | Air Motor Part No. | Ratio | Maximum Working Pressure MPa, bar (psi) | Maximum Air Input Pressure MPa, bar (psi) |
|-----------------------|----------------|---|--------------------|-------|---|---|
| P21DSE, A | 247190 | Dura-Flo 900 (220 cc), 4 leather/1 PTFE | N22DN0 | 21:1 | 14.0, 140 (2030) | 0.7, 7.0 (100) |
| P21ESE, A | 247190 | Dura-Flo 900 (220 cc), 4 leather/1 PTFE | N22DT0 | 21:1 | 14.0, 140 (2030) | 0.7, 7.0 (100) |
| P21LSE, A | 247190 | Dura-Flo 900 (220 cc), 4 leather/1 PTFE | N22LN0 | 21:1 | 14.0, 140 (2030) | 0.7, 7.0 (100) |
| P21MSE, A | 247190 | Dura-Flo 900 (220 cc), 4 leather/1 PTFE | N22LT0 | 21:1 | 14.0, 140 (2030) | 0.7, 7.0 (100) |
| P24DSE, A | 261657 | Dura-Flo 750 (180 cc), 4 leather/1 PTFE | N22DNO | 24:1 | 16.8, 168 (2430) | 0.7, 7.0 (100) |
| P24ESE, A | 261657 | Dura-Flo 750 (180 cc), 4 leather/1 PTFE | N22DTO | 24:1 | 16.8, 168 (2430) | 0.7, 7.0 (100) |
| P24LSE, A | 261657 | Dura-Flo 750 (180 cc), 4 leather/1 PTFE | N22LNO | 24:1 | 16.8, 168 (2430) | 0.7, 7.0 (100) |
| P24MSE, A | 261657 | Dura-Flo 750 (180 cc), 4 leather/1 PTFE | N22LTO | 24:1 | 16.8, 168 (2430) | 0.7, 7.0 (100) |
| P25DSE, A | 237514 | Dura-Flo 1200 (290 cc), 4 leather/1 PTFE | N34DN0 | 25:1 | 16.4, 164 (2380) | 0.7, 7.0 (100) |
| P25ESE, A | 237514 | Dura-Flo 1200 (290 cc), 4 leather/1 PTFE | N34DT0 | 25:1 | 16.4, 164 (2380) | 0.7, 7.0 (100) |
| P25LSE, A | 237514 | Dura-Flo 1200 (290 cc), 4 leather/1 PTFE | N34LN0 | 25:1 | 16.4, 164 (2380) | 0.7, 7.0 (100) |
| P25MSE, A | 237514 | Dura-Flo 1200 (290 cc), 4 leather/1 PTFE | N34LT0 | 25:1 | 16.4, 164 (2380) | 0.7, 7.0 (100) |
| P30DSE, A | 236470 | Dura-Flo 900 (220 cc), 4 leather/1 PTFE | N34DN0 | 30:1 | 21.9, 219 (3170) | 0.7, 7.0 (100) |
| P30ESE, A | 236470 | Dura-Flo 900 (220 cc), 4 leather/1 PTFE | N34DT0 | 30:1 | 21.9, 219 (3170) | 0.7, 7.0 (100) |
| P30LSE, A | 236470 | Dura-Flo 900 (220 cc), 4 leather/1 PTFE | N34LN0 | 30:1 | 21.9, 219 (3170) | 0.7, 7.0 (100) |
| P30MSE, A | 236470 | Dura-Flo 900 (220 cc), 4 leather/1 PTFE | N34LT0 | 30:1 | 21.9, 219 (3170) | 0.7, 7.0 (100) |
| P31DSH, A | 247168 | Dura-Flo 600 (145 cc), PTFE/leather | N22DN0 | 31:1 | 21.0, 210 (3040) | 0.7, 7.0 (100) |
| P31ESH, A | 247168 | Dura-Flo 600 (145 cc), PTFE/leather | N22DT0 | 31:1 | 21.0, 210 (3040) | 0.7, 7.0 (100) |
| P31LSH, A | 247168 | Dura-Flo 600 (145 cc), PTFE/leather | N22LN0 | 31:1 | 21.0, 210 (3040) | 0.7, 7.0 (100) |
| P31MSH, A | 247168 | Dura-Flo 600 (145 cc), PTFE/leather | N22LT0 | 31:1 | 21.0, 210 (3040) | 0.7, 7.0 (100) |

Dura-Flo Pumps with NXT™ Air Motors Part Nos. (continued)

| Pump Part No., Series | Lower Part No. | Lower Model, Packings | Air Motor Part No. | Ratio | Maximum Working Pressure MPa, bar (psi) | Maximum Air Input Pressure MPa, bar (psi) |
|-----------------------|----------------|---|--------------------|-------|---|---|
| P40DSE, A | 236456 | Dura-Flo 750 (180 cc), 4 leather/1 PTFE | N34DN0 | 40:1 | 26.2, 262 (3800) | 0.7, 7.0 (100) |
| P40ESE, A | 236456 | Dura-Flo 750 (180 cc), 4 leather/1 PTFE | N34DT0 | 40:1 | 26.2, 262 (3800) | 0.7, 7.0 (100) |
| P40LSE, A | 236456 | Dura-Flo 750 (180 cc), 4 leather/1 PTFE | N34LN0 | 40:1 | 26.2, 262 (3800) | 0.7, 7.0 (100) |
| P40MSE, A | 236456 | Dura-Flo 750 (180 cc), 4 leather/1 PTFE | N34LT0 | 40:1 | 26.2, 262 (3800) | 0.7, 7.0 (100) |
| P45DSE, A | 237514 | Dura-Flo 1200 (290 cc), 4 leather/1 PTFE | N65DN0 | 45:1 | 31.4, 314 (4550) | 0.7, 7.0 (100) |
| P45ESE, A | 237514 | Dura-Flo 1200 (290 cc), 4 leather/1 PTFE | N65DT0 | 45:1 | 31.4, 314 (4550) | 0.7, 7.0 (100) |
| P45LSE, A | 237514 | Dura-Flo 1200 (290 cc), 4 leather/1 PTFE | N65LN0 | 45:1 | 31.4, 314 (4550) | 0.7, 7.0 (100) |
| P45MSE, A | 237514 | Dura-Flo 1200 (290 cc), 4 leather/1 PTFE | N65LT0 | 45:1 | 31.4, 314 (4550) | 0.7, 7.0 (100) |
| P46DSH, A | 236458 | Dura-Flo 600 (145 cc), PTFE/leather | N34DN0 | 46:1 | 32.8, 328 (4750) | 0.7, 7.0 (100) |
| P46ESH, A | 236458 | Dura-Flo 600 (145 cc), PTFE/leather | N34DT0 | 46:1 | 32.8, 328 (4750) | 0.7, 7.0 (100) |
| P46LSH, A | 236458 | Dura-Flo 600 (145 cc), PTFE/leather | N34LN0 | 46:1 | 32.8, 328 (4750) | 0.7, 7.0 (100) |
| P46MSH, A | 236458 | Dura-Flo 600 (145 cc), PTFE/leather | N34LT0 | 46:1 | 32.8, 328 (4750) | 0.7, 7.0 (100) |

Dura-Flo Pumps with Viscount® Hydraulic Motors



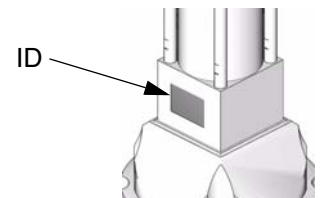

Check your pump's identification plate (ID) for the 6-digit part number of your pump. To order replacement parts, see **Parts** section starting on page 18.



| Pump Part No., Series | Lower Part No. | Lower Model, Packings | Hydraulic Motor Part No. | Ratio | Maximum Working Pressure MPa, bar (psi) | Maximum Hydraulic Input Pressure MPa, bar (psi) |
|-----------------------|----------------|---|--------------------------|-------|---|---|
| 237290, A | 236470 | Dura-Flo 900 (220 cc), 4 leather/1 PTFE | 235345 | 3.5:1 | 34, 345 (5000) | 9.9, 99 (1428) |
| 248817, A | 248816 | Dura-Flo 900 (220 cc), UHMWPE (throat)/ PTFE (piston) | 235345 | 3.5:1 | 34, 345 (5000) | 9.9, 99 (1428) |

Warnings

The following warnings are for the setup, use, grounding, maintenance, and repair of this equipment. The exclamation point symbol alerts you to a general warning and the hazard symbol refers to procedure-specific risk. Refer back to these warnings. Additional, product-specific warnings may be found throughout the body of this manual where applicable.

|  WARNING | |
|--|---|
|  | <p>FIRE AND EXPLOSION HAZARD</p> <p>Flammable fumes, such as solvent and paint fumes, in work area can ignite or explode. To help prevent fire and explosion:</p> <ul style="list-style-type: none"> • Use equipment only in well ventilated area. • Eliminate all ignition sources; such as pilot lights, cigarettes, portable electric lamps, and plastic drop cloths (potential static arc). • Keep work area free of debris, including solvent, rags and gasoline. • Do not plug or unplug power cords, or turn power or light switches on or off when flammable fumes are present. • Ground all equipment in the work area. See Grounding instructions. • Use only grounded hoses. • Hold gun firmly to side of grounded pail when triggering into pail. • If there is static sparking or you feel a shock, stop operation immediately. Do not use equipment until you identify and correct the problem. • Keep a working fire extinguisher in the work area. |
|  | <p>SKIN INJECTION HAZARD</p> <p>High-pressure fluid from gun, hose leaks, or ruptured components will pierce skin. This may look like just a cut, but it is a serious injury that can result in amputation. Get immediate surgical treatment.</p> <ul style="list-style-type: none"> • Do not point gun at anyone or at any part of the body. • Do not put your hand over the spray tip. • Do not stop or deflect leaks with your hand, body, glove, or rag. • Do not spray without tip guard and trigger guard installed. • Engage trigger lock when not spraying. • Follow Pressure Relief Procedure in this manual, when you stop spraying and before cleaning, checking, or servicing equipment. |
|  | <p>EQUIPMENT MISUSE HAZARD</p> <p>Misuse can cause death or serious injury.</p> <ul style="list-style-type: none"> • Do not operate the unit when fatigued or under the influence of drugs or alcohol. • Do not exceed the maximum working pressure or temperature rating of the lowest rated system component. See Technical Data in all equipment manuals. • Use fluids and solvents that are compatible with equipment wetted parts. See Technical Data in all equipment manuals. Read fluid and solvent manufacturer's warnings. For complete information about your material, request MSDS forms from distributor or retailer. • Check equipment daily. Repair or replace worn or damaged parts immediately with genuine manufacturer's replacement parts only. • Do not alter or modify equipment. • Use equipment only for its intended purpose. Call your distributor for information. • Route hoses and cables away from traffic areas, sharp edges, moving parts, and hot surfaces. • Do not kink or over bend hoses or use hoses to pull equipment. • Keep children and animals away from work area. • Comply with all applicable safety regulations. |

 **WARNING**
**MOVING PARTS HAZARD**

Moving parts can pinch or amputate fingers and other body parts.

- Keep clear of moving parts.
- Do not operate equipment with protective guards or covers removed.
- Pressurized equipment can start without warning. Before checking, moving, or servicing equipment, follow the **Pressure Relief Procedure** in this manual. Disconnect power or air supply.

**TOXIC FLUID OR FUMES HAZARD**

Toxic fluids or fumes can cause serious injury or death if splashed in the eyes or on skin, inhaled, or swallowed.

- Read MSDS's to know the specific hazards of the fluids you are using.
- Store hazardous fluid in approved containers, and dispose of it according to applicable guidelines.
- Always wear impervious gloves when spraying or cleaning equipment.

**PERSONAL PROTECTIVE EQUIPMENT**

You must wear appropriate protective equipment when operating, servicing, or when in the operating area of the equipment to help protect you from serious injury, including eye injury, inhalation of toxic fumes, burns, and hearing loss. This equipment includes but is not limited to:

- Protective eyewear
- Clothing and respirator as recommended by the fluid and solvent manufacturer
- Gloves
- Hearing protection

Installation

Grounding

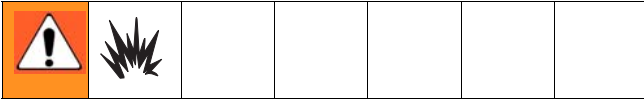

The equipment must be grounded. Grounding reduces the risk of static and electric shock by providing an escape wire for the electrical current due to static build up or in the event of a short circuit.

Pump: Use the ground screw (GS) and lockwasher on the motor to attach a 244524 ground wire (Y). Tighten the screw securely. Connect the other end of the ground wire to a true earth ground.

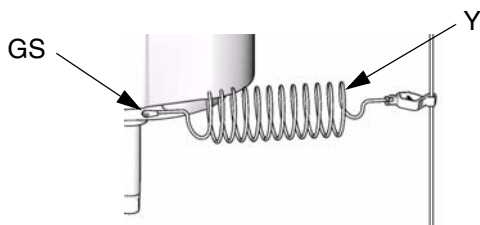

T18250a

Air and fluid hoses: use only electrically conductive hoses.

Air compressor or hydraulic power supply: follow manufacturer's recommendations.

Spray gun: ground through connection to a properly grounded fluid hose and pump.

Fluid supply container: follow local code.

Object being sprayed: follow local code.

Solvent pails used when flushing: follow local code. Use only conductive metal pails, placed on a grounded surface. Do not place the pail on a nonconductive surface, such as paper or cardboard, which interrupts grounding continuity.

To maintain grounding continuity when flushing or relieving pressure: hold metal part of the spray gun firmly to the side of a grounded metal pail, then trigger the gun.

Flush Before Using Equipment

The equipment was tested with lightweight oil, which is left in the fluid passages to protect parts. To avoid contaminating your fluid with oil, flush the equipment with a compatible solvent before using the equipment. See **Flushing**, page 14.

Mounting Accessories

See **Dimensions**, page 22 and **Mounting Hole Layouts**, page 23.

FIG. 1 shows an air-powered system and FIG. 2 shows a hydraulic-powered system.

Hoses

See FIG. 1 and FIG. 2. Be sure all hoses are properly sized and pressure-rated for your system. Use only electrically conductive hoses. Fluid hoses must have spring guards on both ends. Use a whip hose (P) and a swivel (R) between the main fluid hose (N) and the gun/valve (S) to allow freer gun/valve movement.

Air Line Accessories

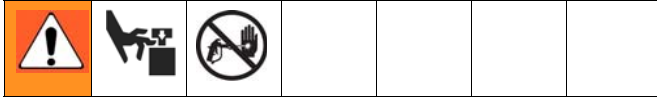

For air-powered pumps, install the following accessories in the order shown in FIG. 1, using adapters as necessary.

 Accessory Air Control Kits are available for the NXT Air Motor. The kits include a master air valve (E), air regulator (F), and filter (J). Order the kit separately. See manual 31 1239 for information.

- **Bleed-type master air valve (E):** required in your system to relieve air trapped between it and the air motor when the valve is closed. Be sure the valve is easily accessible from the pump and located downstream from the air regulator.
- **Pump air regulator (F):** to control pump speed and outlet pressure. Locate it close to the pump.
- **Air line filter (J):** removes harmful dirt and moisture from compressed air supply.
- **Second bleed-type air valve (K):** isolates air line accessories for servicing. Locate upstream from all other air line accessories.

Hydraulic Line Accessories

For hydraulic-powered pumps, install the following accessories in the order shown in FIG. 2, using adapters as necessary.

- Use a minimum 13 mm (1/2 in.) ID **supply line (C)**, and a minimum 22 mm (7/8 in.) ID **return line (D)**. The motor has a 3/4 npt(f) hydraulic oil supply fitting, and a 1 in. npt(f) hydraulic oil return fitting.
- **Supply line shutoff valve (U)** isolates the pump for service.

- **Fluid pressure gauge (F)** monitors hydraulic oil pressure to the motor to avoid overpressurizing the motor or displacement pump.
- **Pressure- and temperature-compensated flow control valve (G)** prevents the motor from running too fast and possibly damaging itself.
- **Pressure reducing valve (H) with a drain line (E)** runs directly to the hydraulic return line (D).
- **Accumulator (J)** reduces the hammering effect caused by the motor reversing direction.
- **Return line shutoff valve (V)** isolates the pump for service.
- Be sure your hydraulic power supply is equipped with a suction filter to the hydraulic pump and a **system return line filter (W)** of 10 micron size.
- Connect a 6 mm (1/4 in.) ID **drain line (K)** to the barbed fitting on the drip pan, and place the free end in a container to collect the drainage.

Fluid Line Accessories

Install the following accessories in the order shown in FIG. 1 and FIG. 2, using adapters as necessary.

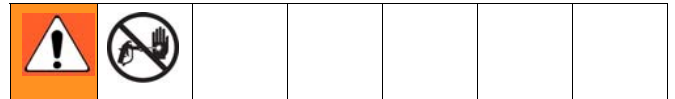

- **Fluid drain valve (M):** required in your system, to relieve fluid pressure in the hose and gun.
- **Fluid filter (L):** with a 60 mesh (250 micron) stainless steel element to filter particles from the fluid as it leaves the pump.
- **Gun or valve (S):** to dispense fluid.
- **Fluid line swivel (R):** for easier gun movement.
- **Suction kit (T):** enables the pump to draw fluid from a container.

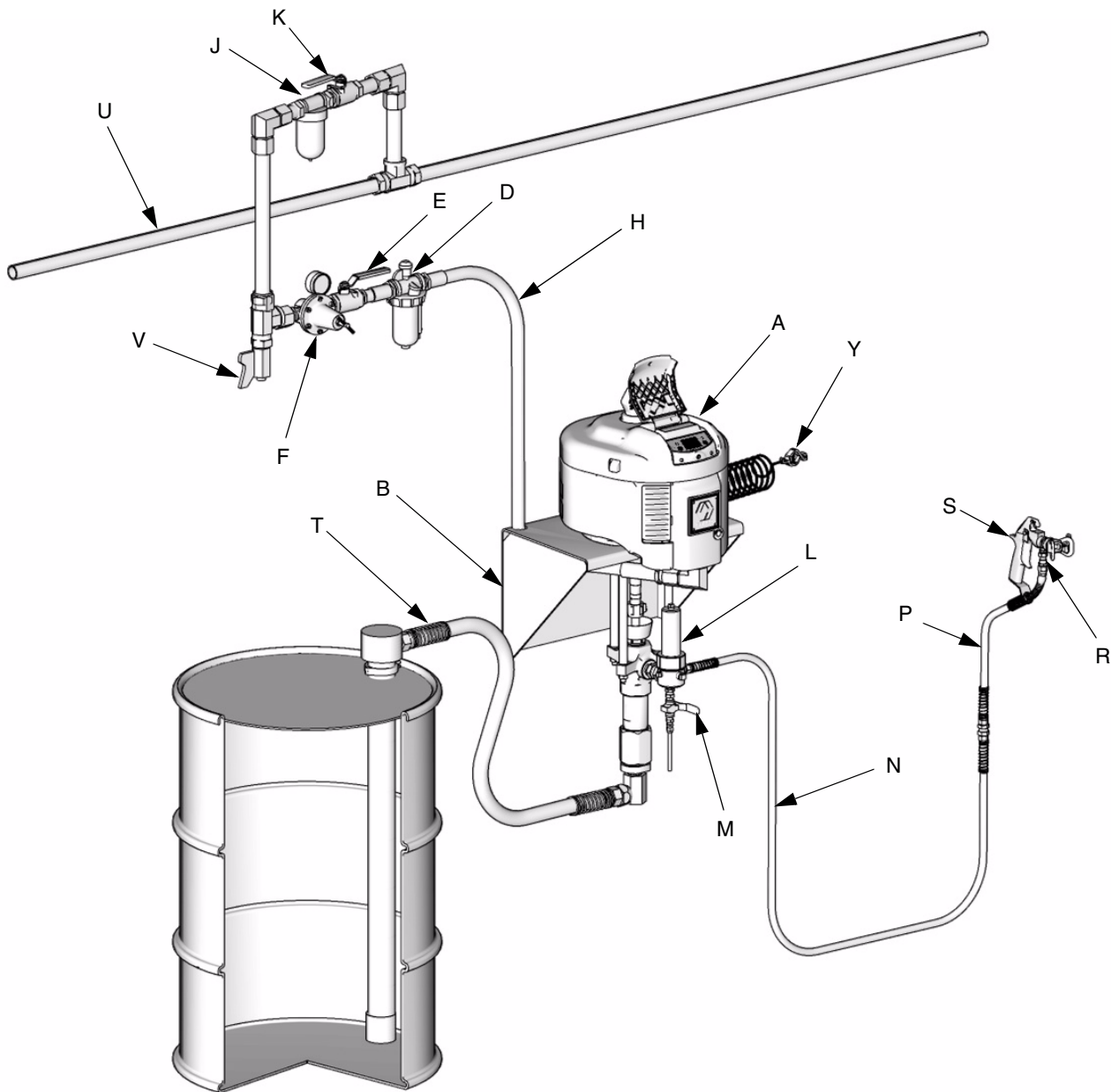

TI8429a

Fig. 1: Typical Installation, Air-Powered Pumps

Key:

- | | | | |
|---|---|---|---|
| A | Pump | N | Electrically Conductive Fluid Supply Hose |
| B | Wall Bracket | P | Fluid Whip Hose |
| D | Air Line Lubricator | R | Gun Swivel |
| E | Bleed-type Master Air Valve (required) | S | Airless Spray Gun |
| F | Pump Air Regulator | T | Fluid Suction Kit |
| H | Electrically Conductive Air Supply Hose | U | Main Air Supply Line |
| J | Air Line Filter | V | Air Line Drain Valve |
| K | Air Shutoff Valve | Y | Pump Ground Wire (required, see page 8 for installation instructions) |
| L | Fluid Filter | | |
| M | Fluid Drain Valve (required) | | |

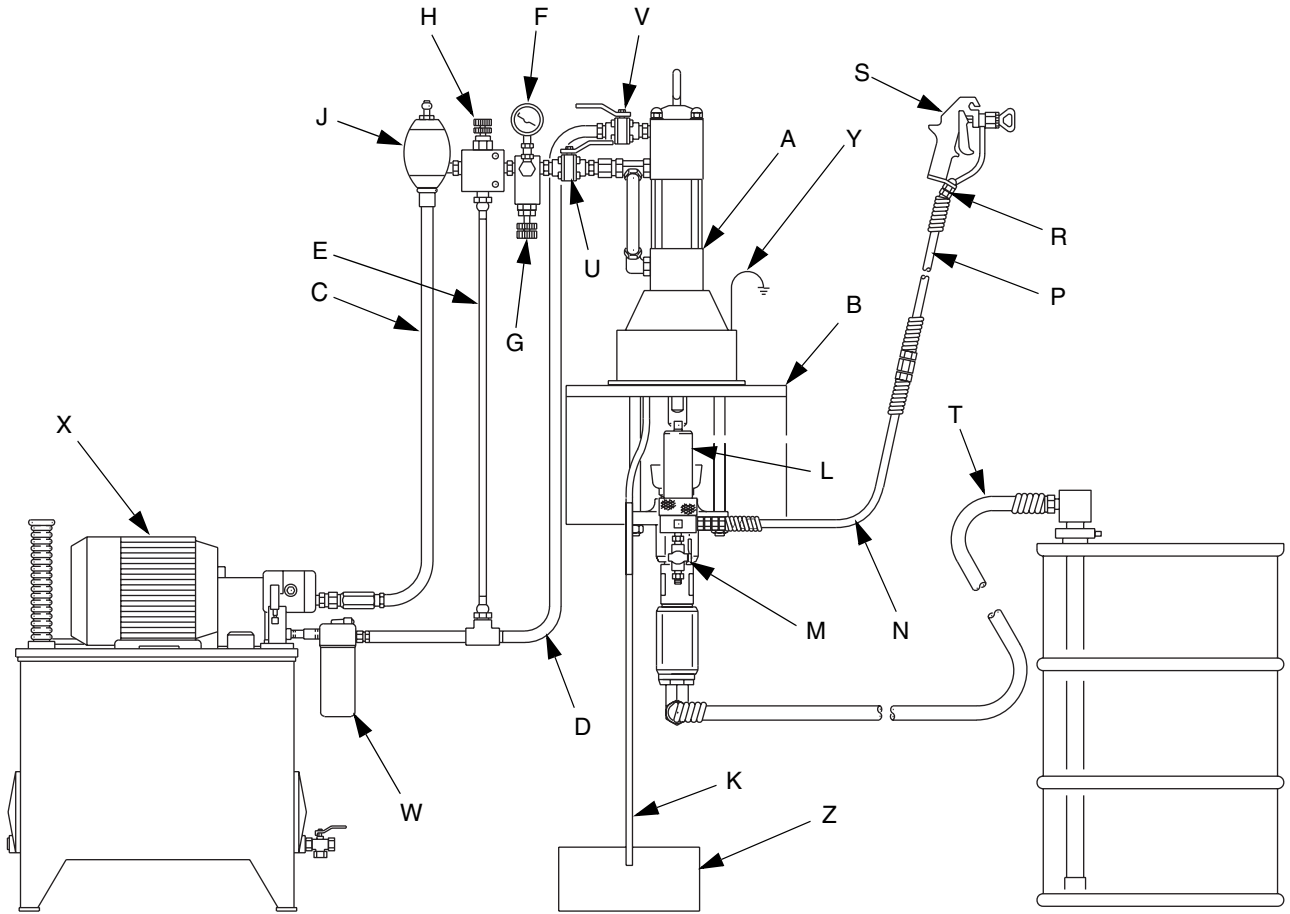

04582b





FIG. 2: Typical Installation, Hydraulic-Powered Pumps

Key:

- | | |
|---|---|
| A Pump | N Electrically Conductive Fluid Supply Hose |
| B Wall Bracket | P Fluid Whip Hose |
| C Hydraulic Supply Line | R Gun Swivel |
| D Hydraulic Return Line | S Airless Spray Gun |
| E Drain Line (from pressure reducing valve) | T Fluid Suction Kit |
| F Pressure Gauge | U Hydraulic Supply Line Shutoff Valve |
| G Flow Control Valve | V Hydraulic Return Line Shutoff Valve |
| H Pressure Reducing Valve | W Hydraulic Return Line Filter |
| J Accumulator | X Hydraulic Power Supply |
| K Drain Line (from motor drip pan) | Y Pump Ground Wire (required, see page 8 for installation instructions) |
| L Fluid Filter | Z Drainage Container |
| M Fluid Drain Valve (required) | |

Operation

Pressure Relief Procedure

| | | | | | | |
|--|---|---|---|---|--|--|
|  |  |  |  |  | | |
| Trapped air can cause the pump to cycle unexpectedly, which could result in serious injury from splashing or moving parts. | | | | | | |

1. Engage trigger lock.
2. Shutoff the pump:
 - a. *For air-powered pumps*, close the bleed-type master air valve.
 - b. *For hydraulic-powered pumps*, close the supply line shutoff valve (U) first, then close the return line shutoff valve (V).
3. Disengage the trigger lock.

4. Hold a metal part of the gun firmly to a grounded metal pail. Trigger the gun to relieve pressure.
5. Engage the trigger lock.
6. Open all fluid drain valves in the system, having a waste container ready to catch drainage. Leave drain valve(s) open until you are ready to spray again.
7. If you suspect the spray tip or hose is clogged or that pressure has not been fully relieved after following the steps above, **VERY SLOWLY** loosen tip guard retaining nut or hose end coupling to relieve pressure gradually, then loosen completely. Clear hose or tip obstruction.

Trigger Lock

Always engage the trigger lock when you stop spraying to prevent the gun from being triggered accidentally by hand or if dropped or bumped.

Startup

1. Connect the suction kit (T) to the pump's fluid inlet, and place the tube into the fluid supply.
2. Prepare the pump's power source:
 - a. *For air-powered pumps*, close the air regulator (F). Open the pump's bleed-type master air valve (E).
 - b. *For hydraulic-powered pumps*, check the hydraulic fluid level before each use, and add fluid as necessary. Close the supply line shutoff valve (U) and the return line shutoff valve (V). Start the hydraulic power supply.
3. Hold a metal part of the gun (S) firmly to the side of a grounded metal pail and hold the trigger open.
4. Start the pump:
 - a. *For air-powered pumps*, slowly open the air regulator until the pump starts.
 - b. *For hydraulic-powered pumps*, open the return line shutoff valve (V) first, then slowly open the supply line shutoff valve (U).
5. Cycle the pump slowly until all air is pushed out and the pump and hoses are fully primed. Release the gun trigger and lock the trigger safety latch. The pump should stall against pressure when the trigger is released.
6. With the pump and lines primed, and with adequate air or hydraulic pressure and volume supplied, the pump will start and stop as the gun is opened and closed. In a circulating system, the pump will speed

up or slow down on demand, until the air or hydraulic supply is shut off.

7. Always use the lowest air or hydraulic pressure necessary to get the desired results. Higher pressures cause premature tip/nozzle and pump wear.
 - a. *For air-powered pumps*, use the air regulator (F) to control the pump speed and fluid pressure.
 - b. *For hydraulic-powered pumps*, use the fluid pressure gauge (F) and flow control valve (G) to control the pump speed and the fluid pressure.
8. Never allow the pump to run dry of the fluid being pumped. A dry pump will quickly accelerate to a high speed, possibly damaging itself.



If your pump accelerates quickly, or is running too fast, stop it immediately and check the fluid supply. If the supply container is empty and air has been pumped into the lines, refill the container and prime the pump and the lines with fluid, or flush and leave it filled with a compatible solvent. Be sure to eliminate all air from the fluid system.

Shutdown

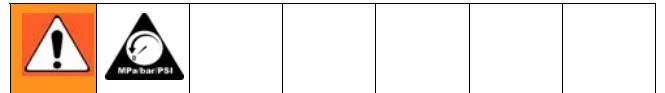

Relieve the pressure, page 12. Stop the pump at the bottom of its stroke to prevent fluid from drying on the exposed displacement rod and damaging the throat packings.

Maintenance

Preventive Maintenance Schedule

The operating conditions of your particular system determine how often maintenance is required. Establish a preventive maintenance schedule by recording when and what kind of maintenance is needed, and then determine a regular schedule for checking your system.

Wet-Cups

Check the wet-cup daily. Keep the wet-cup 1/3 filled with Graco Throat Seal Liquid (TSL) or compatible solvent.

Flushing



- Flush before changing colors, before fluid can dry in the equipment, at the end of the day, before storing, and before repairing equipment.
 - Flush at the lowest pressure possible. Check connectors for leaks and tighten as necessary.
 - Flush with a fluid that is compatible with the fluid being dispensed and the equipment wetted parts.
1. Follow **Pressure Relief Procedure**, page 12.
 2. Remove spray tip and soak in solvent.
 3. Place siphon tube in grounded metal pail containing cleaning fluid.
 4. Set pump to lowest possible fluid pressure, and start pump.

5. Hold a metal part of the gun firmly to a grounded metal pail. Trigger the gun until clean solvent dispenses.
6. Remove gun from hose. See gun manual to further clean gun.
7. Follow **Pressure Relief Procedure**, page 12, and remove fluid filter and soak in solvent. Replace filter cap.

Corrosion Protection

Always flush the pump before the fluid dries on the displacement rod. Never leave water or water-based fluid in the pump overnight. First, flush with water or a compatible solvent, then with mineral spirits. Relieve the pressure, but leave the mineral spirits in the pump to protect the parts from corrosion.

Hydraulic Systems

CAUTION

Keep the hydraulic supply system absolutely clean at all times. Blow out hydraulic lines with air and flush thoroughly with solvent before connecting to the hydraulic motor, to avoid introducing harmful contaminants into the motor. Plug the hydraulic lines immediately when they are disconnected.

Do not exceed 37.8 liter/min (10 gpm) hydraulic oil volume to the motor, to avoid stalling the pump.

Do not exceed 54°C (130°F) hydraulic oil temperature.

Carefully follow the manufacturer's recommendations on reservoir and filter cleaning, and periodic changes of hydraulic fluid. Use only Graco-approved hydraulic oil. Order Part No. 169236, 5 gal. (19 liter) or 207428, 1 gal. (3.8 liter). Do not substitute a lower grade oil or one with a lower flash point.

Troubleshooting

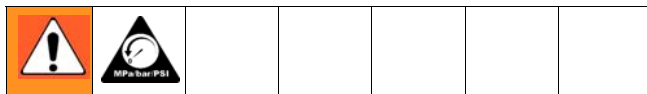

1. Relieve the pressure, page 12.
2. Check all possible causes and problems before disassembling the pump.

| Problem | Cause | Solution |
|--|---|---|
| Pump fails to operate. | Restricted line or inadequate air/hydraulic supply; closed or clogged valves. | Clear; increase air/hydraulic supply. Check that valves are open. |
| | Obstructed fluid hose or gun/valve; fluid hose ID is too small. | Open, clear*; use hose with larger ID |
| | Fluid dried on displacement rod. | Clean; always stop pump at bottom of stroke; keep wet-cup 1/3 filled with compatible solvent. |
| | Dirty, worn, or damaged motor parts. | Clean or repair; see separate motor manual. |
| Pump operates, but output low on both strokes. | Restricted line or inadequate air/hydraulic supply; closed or clogged valves. | Clear; increase air/hydraulic supply. Check that valves are open. |
| | Obstructed fluid hose or gun/valve; fluid hose ID is too small. | Open, clear*; use hose with larger ID |
| | Bleeder valve open. | Close. |
| | Fluid too heavy for pump priming. | Use ram. |
| | Worn packings in lower. | Replace packings. |
| Pump operates, but output low on downstroke. | Held open or worn intake valve. | Clear valve; service. |
| | Fluid too heavy for pump priming. | Use ram. |
| Pump operates, but output low on upstroke. | Held open or worn piston valve or packings. | Clear valve; replace packings. |
| Erratic or accelerated pump speed. | Exhausted fluid supply. | Refill and prime. |
| | Fluid too heavy for pump priming. | Use ram. |
| | Held open or worn piston valve or packings. | Clear valve; replace packings. |
| | Held open or worn intake valve. | Clear valve; service. |

* To determine if the fluid hose or gun is obstructed, relieve the pressure, page 12. Disconnect the fluid hose and place a container at the pump fluid outlet to catch any fluid. Turn on the air/hydraulic power just enough to start the pump. If the pump starts, the obstruction is in the fluid hose or gun.

Repair

Required Tools

- Set of adjustable wrenches
- Large pipe wrench
- 2-5/8 in. wrench
- Torque wrench
- Rubber mallet
- O-ring pick
- Large vise
- Thread lubricant
- Thread sealant

Disconnect the Lower

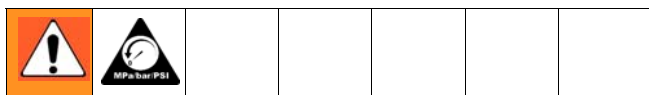

1. Flush the pump, if possible. Stop the pump at the bottom of its stroke. Relieve the pressure, page 12.
2. Disconnect the air or hydraulic hose. Plug all hydraulic hoses immediately, to prevent contamination of the hydraulic system.
3. Disconnect the fluid hose.

CAUTION

Use at least two people when lifting, moving, or disconnecting the pump. If disconnecting the lower, be sure to securely brace the pump, or have two people hold it while another disconnects it.

For cart-mounted pumps, tip the cart backward until the handle rests on the ground, then disconnect the lower.

-  Before disconnecting the lower (102) from the motor (101), be sure to note the relative position of the pump's fluid outlet to the air or hydraulic inlet of the motor. If the motor does not require servicing, leave it attached to its mounting.

4. Unscrew the coupling nut (103) from the connecting rod adapter (105). Remove the coupling collars (104); do not lose or drop them. See FIG. 3.
5. Hold the tie rod flats with a wrench to keep the rods (106) from turning. Unscrew the nuts (107). Remove the lower (102).
6. To service the lower, refer to manual 308354, supplied. To service the air or hydraulic motor, refer to the separate motor manual, supplied.

Reconnect the Lower

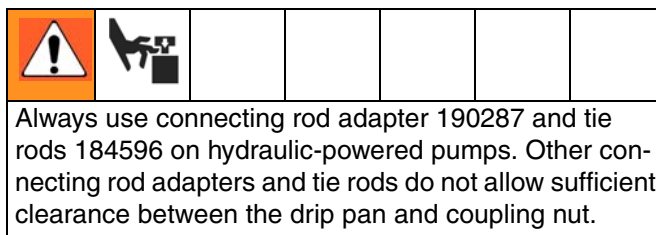

1. If the connecting rod adapter (105) was disconnected, screw it into the air motor shaft. Torque as noted in FIG. 3.
2. Screw the tie rods (106) into the air motor (101). Using a wrench on the tie rod flats, torque as noted.
3. Make sure the coupling nut (103) and coupling collars (104) are in place on the displacement rod (DR).
4. Use at least two people to hold the lower while another reconnects it to the motor (see the **CAUTION**, page 16). Orient the pump's fluid outlet to the air or hydraulic inlet as noted under **Disconnect the Lower**. Place the lower (102) on the tie rods (106).

5. Screw the nuts (107) onto the tie rods (106). Torque as noted in FIG. 3.
6. Screw the coupling nut (103) onto the motor shaft (MS) loosely. Hold the motor shaft flats with a wrench to keep it from turning. Use an adjustable wrench to tighten the coupling nut. Torque as noted in FIG. 3.
7. Tighten the packing nut/wet-cup (PN) as specified in the lower pump manual 308354.
8. Reconnect all hoses. Reconnect the ground wire if it was disconnected. Fill the packing nut/wet-cup (PN) 1/3 full of Graco Throat Seal Liquid or compatible solvent.
9. Turn on the air or hydraulic power supply. On hydraulic pumps, open the hydraulic return line valve first, then the supply line valve. Run the pump slowly to ensure that it operates properly, or prime pump (see **Startup** on page 13).

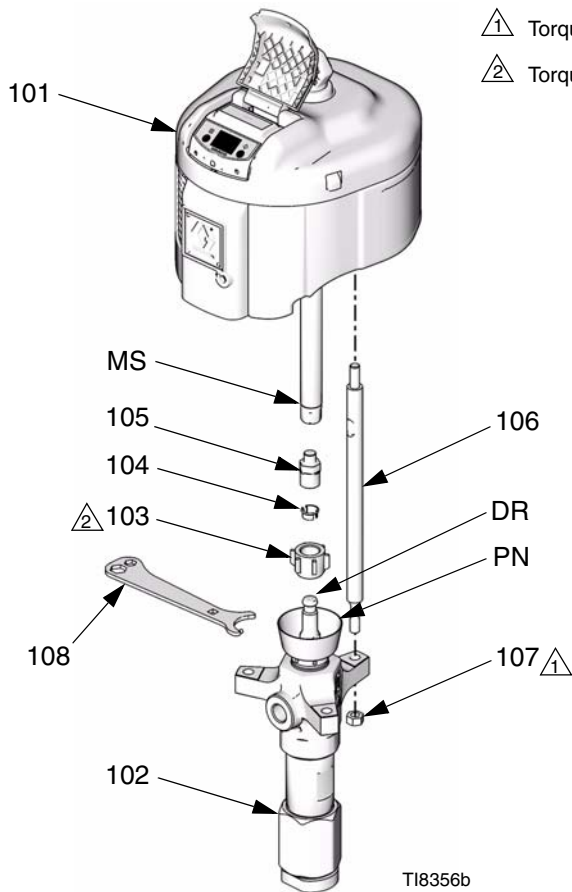

- △1 Torque to 68-81 N•m (50-60 ft-lb).
- △2 Torque to 196-210 N•m (145-155 ft-lb).

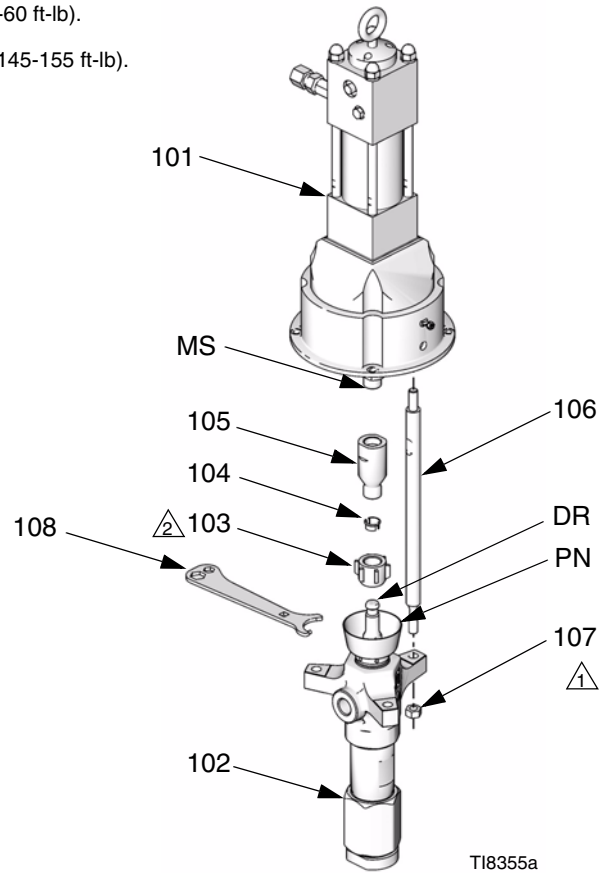
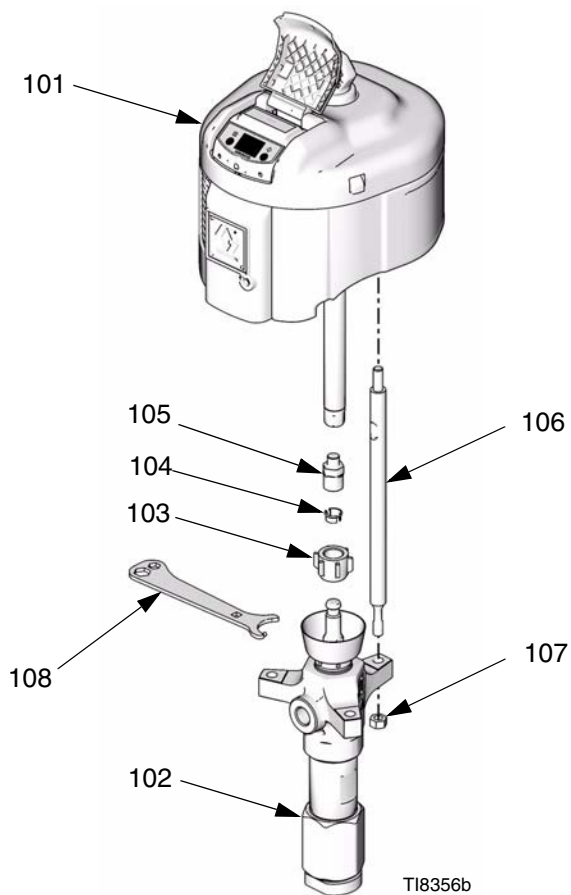

FIG. 3. Reconnect the Lower

Parts

Dura-Flo Pumps with NXT Air Motors



| Pump Part No. | Ref. Nos. and Descriptions | | | | | | | |
|---------------|----------------------------|-------------------|---------------|------------------|----------|----------|------------------|----------|
| | 101 | 102 | 103 | 104 | 105 | 106 | 107 | 108 |
| | MOTOR; see 311238 | LOWER; see 308354 | NUT, coupling | COLLAR, coupling | ADAPTER | ROD, tie | NUT, hex; 5/8-11 | WRENCH |
| P16DSE | N22DN0 | 247192 | 186925 | 184129 | 15H370 | 15H562 | 101712 | 112887 |
| P16ESE | N22DT0 | 247192 | 186925 | 184129 | 15H370 | 15H562 | 101712 | 112887 |
| P16LSE | N22LN0 | 247192 | 186925 | 184129 | 15H370 | 15H562 | 101712 | 112887 |
| P16MSE | N22LT0 | 247192 | 186925 | 184129 | 15H370 | 15H562 | 101712 | 112887 |
| P21DSE | N22DN0 | 247190 | 186925 | 184129 | 15H370 | 15H562 | 101712 | 112887 |
| P21ESE | N22DT0 | 247190 | 186925 | 184129 | 15H370 | 15H562 | 101712 | 112887 |
| P21LSE | N22LN0 | 247190 | 186925 | 184129 | 15H370 | 15H562 | 101712 | 112887 |
| P21MSE | N22LT0 | 247190 | 186925 | 184129 | 15H370 | 15H562 | 101712 | 112887 |
| Qty | 1 | 1 | 1 | 2 | 1 | 3 | 3 | 1 |

| Pump Part No. | Ref. Nos. and Descriptions | | | | | | | |
|---------------|----------------------------|-------------------|---------------|------------------|---------|----------|------------------|--------|
| | 101 | 102 | 103 | 104 | 105 | 106 | 107 | 108 |
| | MOTOR; see 311238 | LOWER; see 308354 | NUT, coupling | COLLAR, coupling | ADAPTER | ROD, tie | NUT, hex; 5/8-11 | WRENCH |
| P24DSE | N22DNO | 261657 | 186925 | 184129 | 15H370 | 15H562 | 101712 | 112887 |
| P24ESE | N22DTO | 261657 | 186925 | 184129 | 15H370 | 15H562 | 101712 | 112887 |
| P24LSE | N22LNO | 261657 | 186925 | 184129 | 15H370 | 15H562 | 101712 | 112887 |
| P24MSE | N22LTO | 261657 | 186925 | 184129 | 15H370 | 15H562 | 101712 | 112887 |
| P25DSE | N34DNO | 237514 | 186925 | 184129 | 15H370 | 15H562 | 101712 | 112887 |
| P25ESE | N34DT0 | 237514 | 186925 | 184129 | 15H370 | 15H562 | 101712 | 112887 |
| P25LSE | N34LNO | 237514 | 186925 | 184129 | 15H370 | 15H562 | 101712 | 112887 |
| P25MSE | N34LTO | 237514 | 186925 | 184129 | 15H370 | 15H562 | 101712 | 112887 |
| P30DSE | N34DNO | 236470 | 186925 | 184129 | 15H370 | 15H562 | 101712 | 112887 |
| P30ESE | N34DT0 | 236470 | 186925 | 184129 | 15H370 | 15H562 | 101712 | 112887 |
| P30LSE | N34LNO | 236470 | 186925 | 184129 | 15H370 | 15H562 | 101712 | 112887 |
| P30MSE | N34LTO | 236470 | 186925 | 184129 | 15H370 | 15H562 | 101712 | 112887 |
| P31DSH | N22DNO | 247168 | 186925 | 184129 | 15H370 | 15H562 | 101712 | 112887 |
| P31ESH | N22DTO | 247168 | 186925 | 184129 | 15H370 | 15H562 | 101712 | 112887 |
| P31LSH | N22LNO | 247168 | 186925 | 184129 | 15H370 | 15H562 | 101712 | 112887 |
| P31MSH | N22LTO | 247168 | 186925 | 184129 | 15H370 | 15H562 | 101712 | 112887 |
| P40DSE | N34DNO | 236456 | 186925 | 184129 | 15H370 | 15H562 | 101712 | 112887 |
| P40ESE | N34DT0 | 236456 | 186925 | 184129 | 15H370 | 15H562 | 101712 | 112887 |
| P40LSE | N34LNO | 236456 | 186925 | 184129 | 15H370 | 15H562 | 101712 | 112887 |
| P40MSE | N34LTO | 236456 | 186925 | 184129 | 15H370 | 15H562 | 101712 | 112887 |
| P45DSE | N65DNO | 237514 | 186925 | 184129 | 15H370 | 15H562 | 101712 | 112887 |
| P45ESE | N65DT0 | 237514 | 186925 | 184129 | 15H370 | 15H562 | 101712 | 112887 |
| P45LSE | N65LNO | 237514 | 186925 | 184129 | 15H370 | 15H562 | 101712 | 112887 |
| P45MSE | N65LTO | 237514 | 186925 | 184129 | 15H370 | 15H562 | 101712 | 112887 |
| P46DSH | N34DNO | 236458 | 186925 | 184129 | 15H370 | 15H562 | 101712 | 112887 |
| P46ESH | N34DT0 | 236458 | 186925 | 184129 | 15H370 | 15H562 | 101712 | 112887 |
| P46LSH | N34LNO | 236458 | 186925 | 184129 | 15H370 | 15H562 | 101712 | 112887 |
| P46MSH | N34LTO | 236458 | 186925 | 184129 | 15H370 | 15H562 | 101712 | 112887 |
| Qty | 1 | 1 | 1 | 2 | 1 | 3 | 3 | 1 |

Dura-Flo Pumps with Viscount Hydraulic Motors

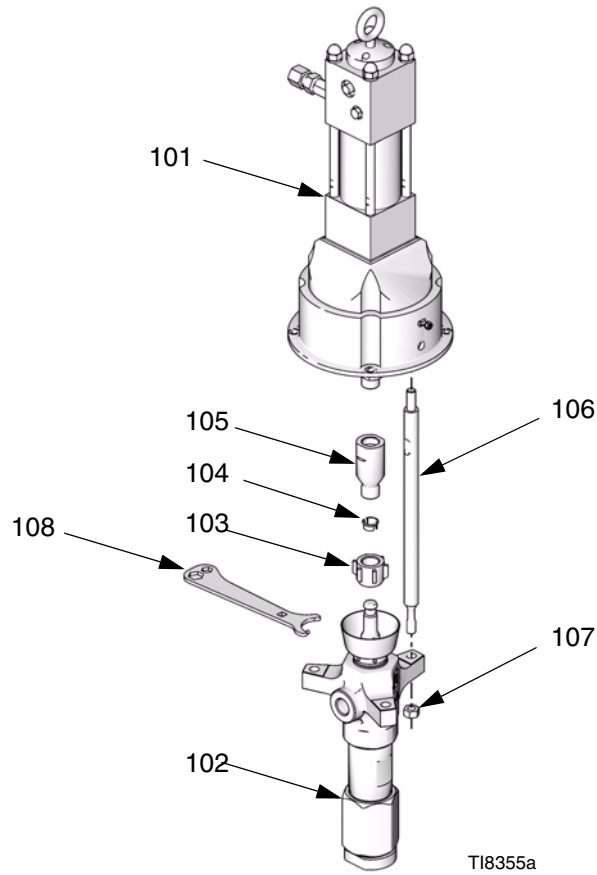

| Pump Part No. | Ref. Nos. and Descriptions | | | | | | | |
|---------------|----------------------------|-------------------|---------------|------------------|---------|----------|------------------|--------|
| | 101 | 102 | 103 | 104 | 105 | 106 | 107 | 108 |
| | MOTOR; see 307158 | LOWER; see 308354 | NUT, coupling | COLLAR, coupling | ADAPTER | ROD, tie | NUT, hex; 5/8-11 | WRENCH |
| 237290 | 235345 | 236470 | 186925 | 184129 | 190287 | 184596 | 106166 | 112887 |
| 248817 | 235345 | 248816 | 186925 | 184129 | 190287 | 184596 | 106166 | 112887 |
| Qty | 1 | 1 | 1 | 2 | 1 | 3 | 3 | 1 |



A series of 21 horizontal lines spanning the width of the page, providing a ruled area for writing.

Dimensions

Dura-Flo Pumps with NXT Air Motors

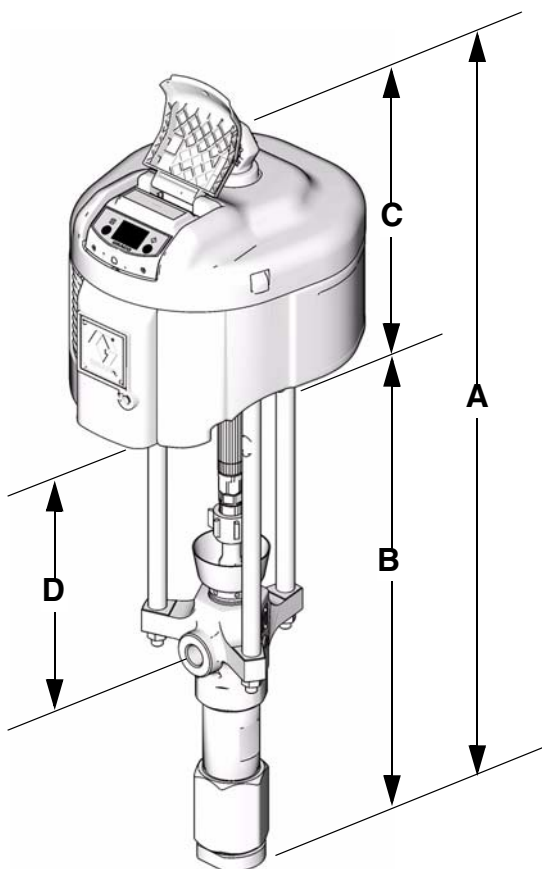

T18357a

Dura-Flo Pumps with Viscount Hydraulic Motors

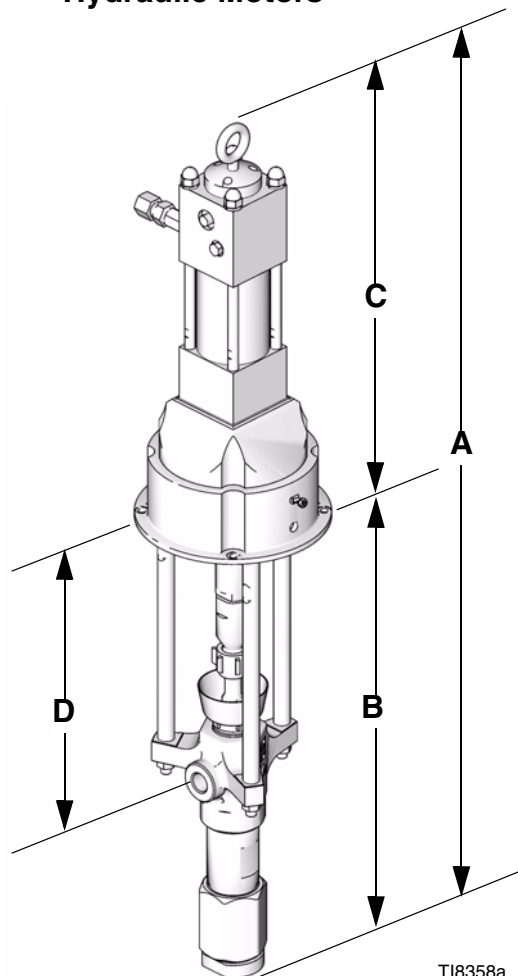

T18358a

| Motor Model | Pump Model | A mm (in.) | B mm (in.) | C mm (in.) | D mm (in.) | Weight kg (lb) w/600, 750 lower | Weight kg (lb) w/900, 1200 lower |
|----------------|------------|---------------|---------------|---------------|---------------|--|---|
| NXT Model 2200 | All | 1100 (43.3) | 756 (29.78) | 340 (13.52) | 430 (16.79) | 42 (86) | 56 (122) |
| NXT Model 3400 | All | 1100 (43.3) | 756 (29.78) | 340 (13.52) | 430 (16.79) | 51 (92) | 57 (126) |
| NXT Model 6500 | All | 1100 (43.3) | 756 (29.78) | 340 (13.52) | 430 (16.79) | n/a | 67 (146) |
| Viscount | All | 1344 (52.9) | 681 (26.8) | 663 (26.1) | 350 (13.81) | n/a | 68 (150) |

Mounting Hole Layouts

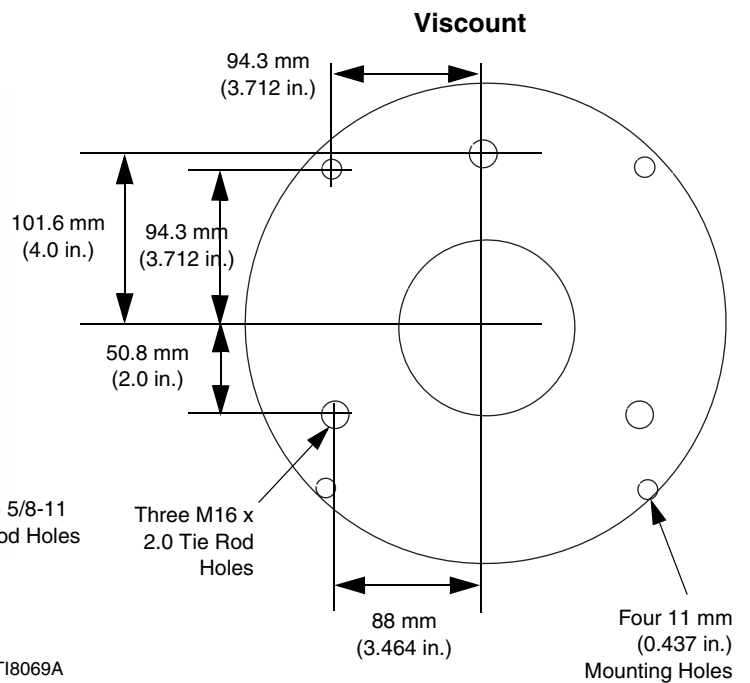
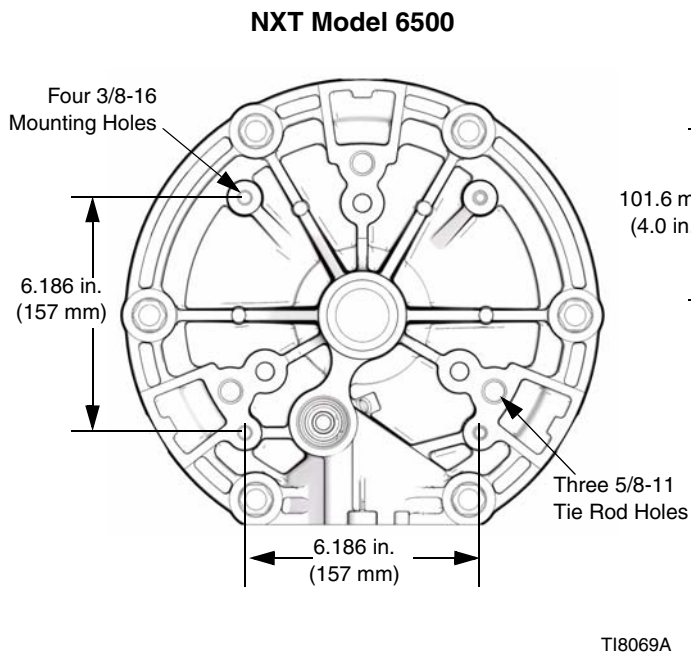
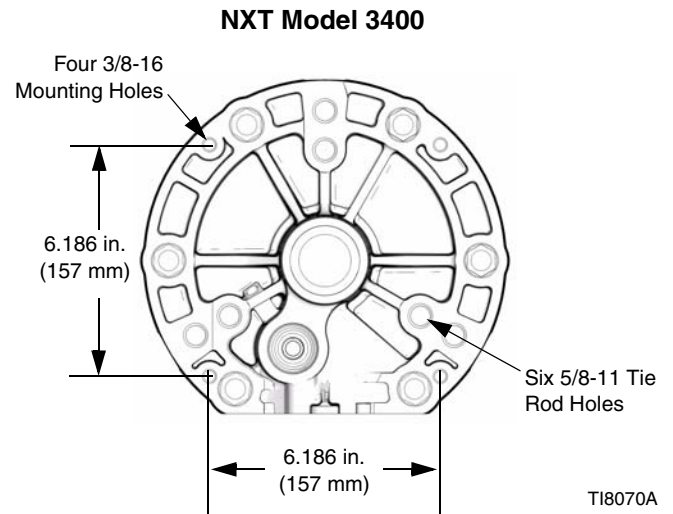
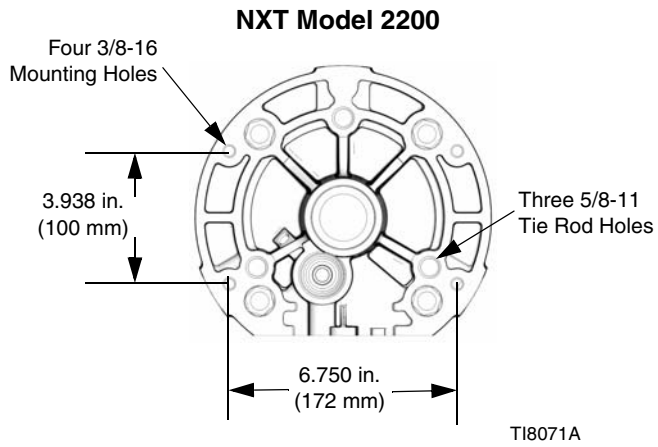

0653

Technical Data

| | |
|--|--|
| Ratio | See Models , page 3. |
| Maximum fluid working pressure | See Models , page 3. |
| Maximum air/hydraulic working pressure | See Models , page 3. |
| Pump cycles per 3.8 liters (1 gal.) | Dura-Flo 600 (145 cc): 26.0 Dura-Flo 750 (180 cc): 21.0 Dura-Flo 900 (220 cc): 18.0 Dura-Flo 1200 (290 cc): 12.5 |
| Fluid flow at 60 cpm | Dura-Flo 600 (145 cc): 8.7 liters/min (2.3 gpm) Dura-Flo 750 (180 cc): 11.0 liters/min (2.9 gpm) Dura-Flo 900 (220 cc): 12.9 liters/min (3.4 gpm) Dura-Flo 1200 (290 cc): 17.4 liters/min (4.6 gpm) |
| Motor piston effective area | See motor manual, supplied. |
| Stroke length | See motor manual, supplied. |
| Lower effective area | See lower manual 308354, supplied. |
| Maximum pump operating temperature | 65.5°C (150°F) |
| Motor fitting sizes | See motor manual, supplied. |
| Fluid inlet size | See lower manual 308354, supplied. |
| Fluid outlet size | See lower manual 308354, supplied. |
| Sound pressure | NXT air motors: See manual 311238, supplied. Viscount hydraulic motors: 88 dB(A) at 1450 psi hydraulic pressure, 25 cycles/min (tested in accordance with ISO 3744) |
| Sound power | NXT air motors: See manual 311238, supplied. Viscount hydraulic motors: 103 dB(A) at 1450 psi hydraulic pressure, 25 cycles/min (tested in accordance with ISO 3744) |
| Wetted parts | See lower manual 308354, supplied. |

Pump Performance Charts (see pages 25-29)

Fluid Outlet Pressure

To find fluid outlet pressure (MPa/bar/psi) at a specific flow (lpm/gpm) and operating pressure (A/B/C):

1. Locate desired flow at bottom of chart.
2. Follow vertical line up to intersection with selected operating pressure curve (solid line). Follow left to scale to read fluid outlet pressure.

Pump Air or Hydraulic Oil Consumption

To find air or hydraulic oil consumption at a specific flow (lpm/gpm) and operating pressure (A/B/C):

1. Locate desired flow at bottom of chart.
2. Follow vertical line up to intersection with selected operating pressure curve (dashed line). Follow left to scale to read air or oil consumption.

Key

- A** 0.7 MPa, 7 bar (100 psi) air pressure or 10.5 MPa, 105 bar (1500 psi) hydraulic oil pressure
 - B** 0.5 MPa, 4.9 bar (70 psi) air pressure or 7.5 MPa, 75 bar (1050 psi) hydraulic oil pressure
 - C** 0.3 MPa, 2.8 bar (40 psi) air pressure or 4.2 MPa, 42 bar (600 psi) hydraulic oil pressure
- Test Fluid:** No. 10 Weight Oil

Dura-Flo 600 Pumps with NXT Model 2200 Air Motors

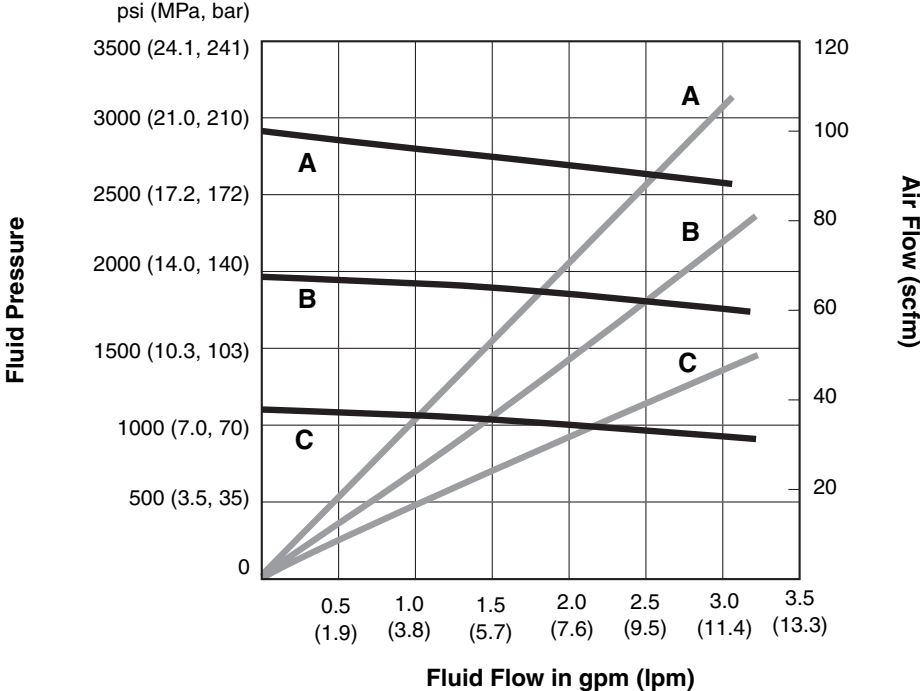

Dura-Flo 600 Pumps with NXT Model 3400 Air Motors

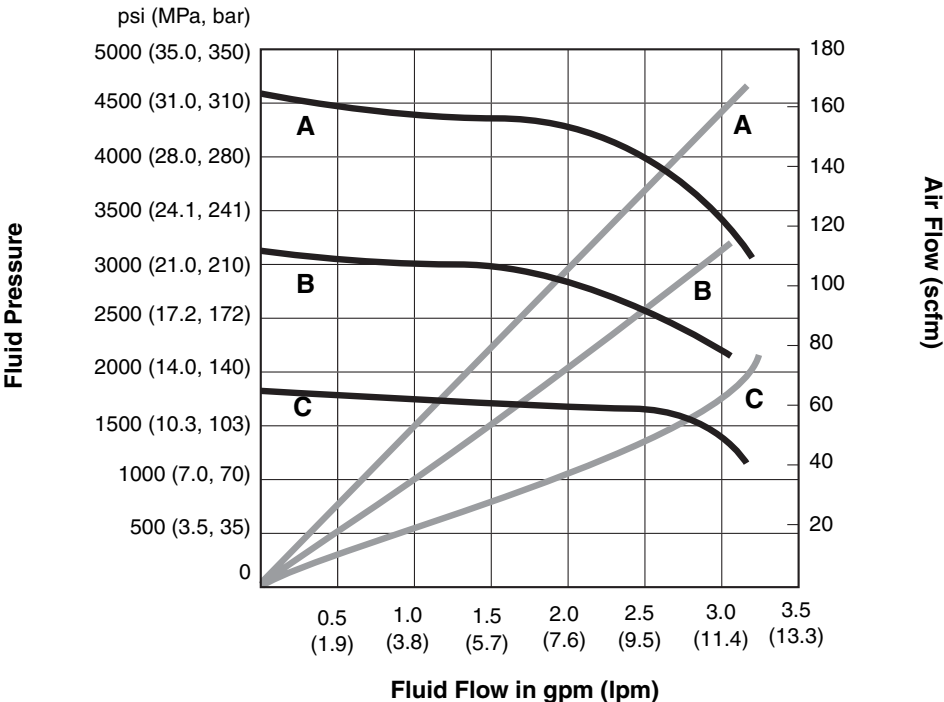

Key

- A** 0.7 MPa, 7 bar (100 psi) air pressure or 10.5 MPa, 105 bar (1500 psi) hydraulic oil pressure
 - B** 0.5 MPa, 4.9 bar (70 psi) air pressure or 7.5 MPa, 75 bar (1050 psi) hydraulic oil pressure
 - C** 0.3 MPa, 2.8 bar (40 psi) air pressure or 4.2 MPa, 42 bar (600 psi) hydraulic oil pressure
- Test Fluid:** No. 10 Weight Oil

Dura-Flo 750 Pumps with NXT Model 3400 Air Motors

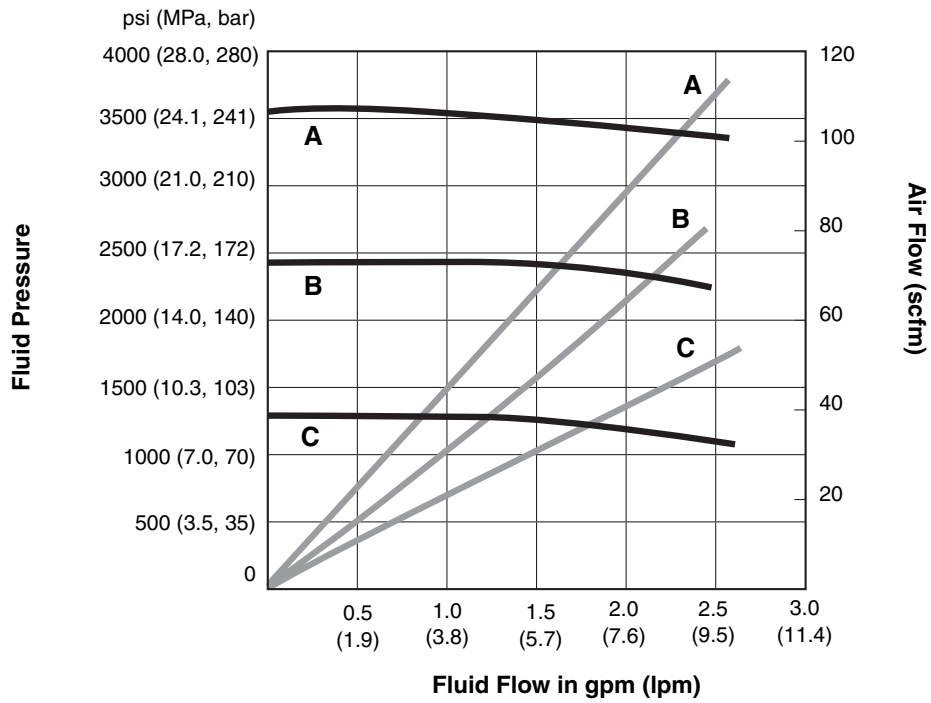

Key

- A** 0.7 MPa, 7 bar (100 psi) air pressure or 10.5 MPa, 105 bar (1500 psi) hydraulic oil pressure
 - B** 0.5 MPa, 4.9 bar (70 psi) air pressure or 7.5 MPa, 75 bar (1050 psi) hydraulic oil pressure
 - C** 0.3 MPa, 2.8 bar (40 psi) air pressure or 4.2 MPa, 42 bar (600 psi) hydraulic oil pressure
- Test Fluid:** No. 10 Weight Oil

Dura-Flo 900 Pumps with NXT Model 2200 Air Motors

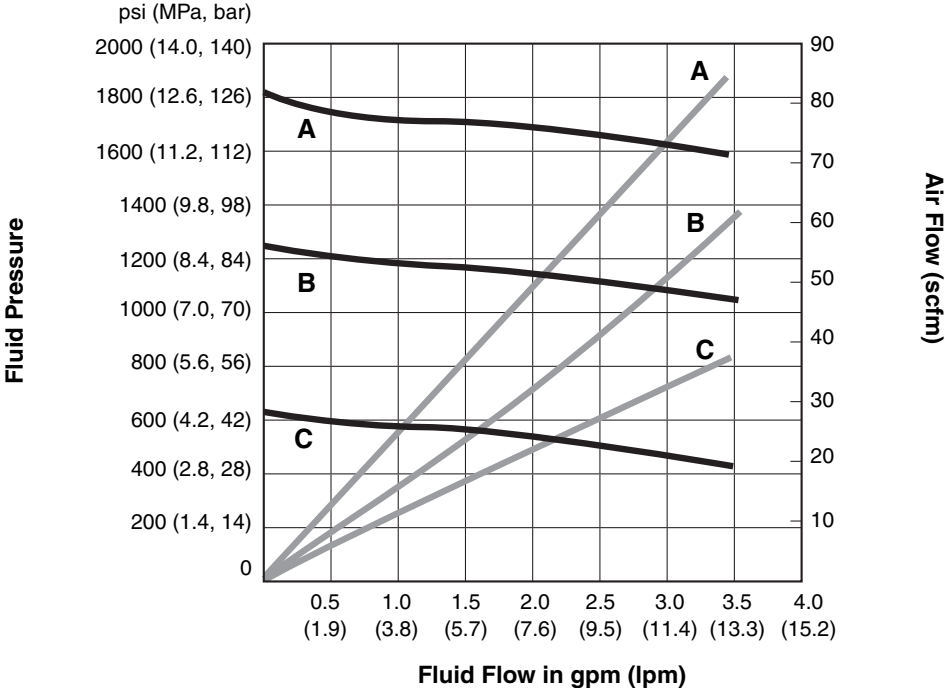

Dura-Flo 900 Pumps with NXT Model 3400 Air Motors

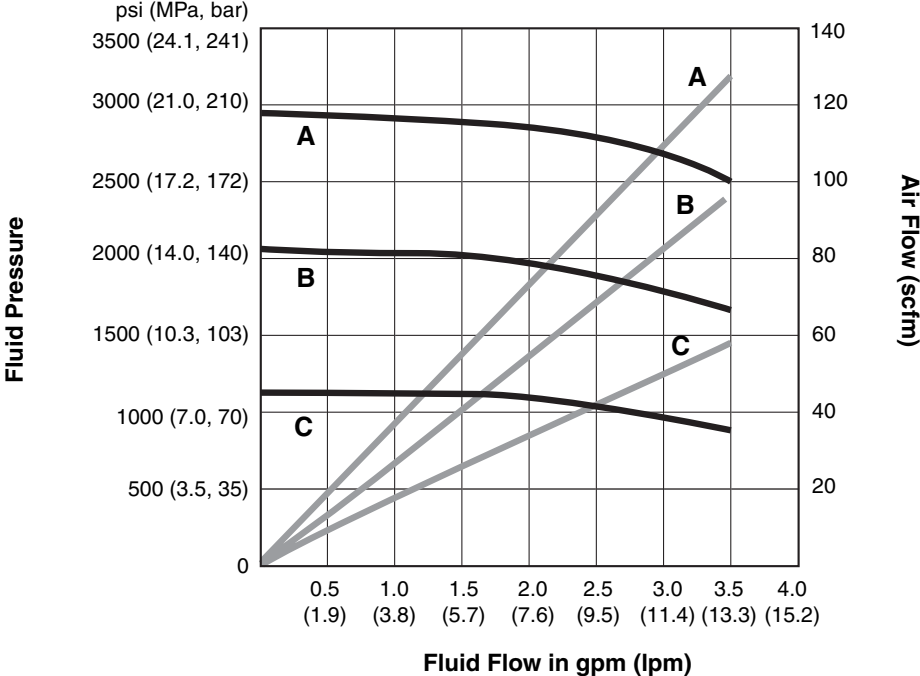

Key

- A** 0.7 MPa, 7 bar (100 psi) air pressure or 10.5 MPa, 105 bar (1500 psi) hydraulic oil pressure
 - B** 0.5 MPa, 4.9 bar (70 psi) air pressure or 7.5 MPa, 75 bar (1050 psi) hydraulic oil pressure
 - C** 0.3 MPa, 2.8 bar (40 psi) air pressure or 4.2 MPa, 42 bar (600 psi) hydraulic oil pressure
- Test Fluid:** No. 10 Weight Oil

Dura-Flo 1200 Pumps with NXT Model 3400 Air Motors

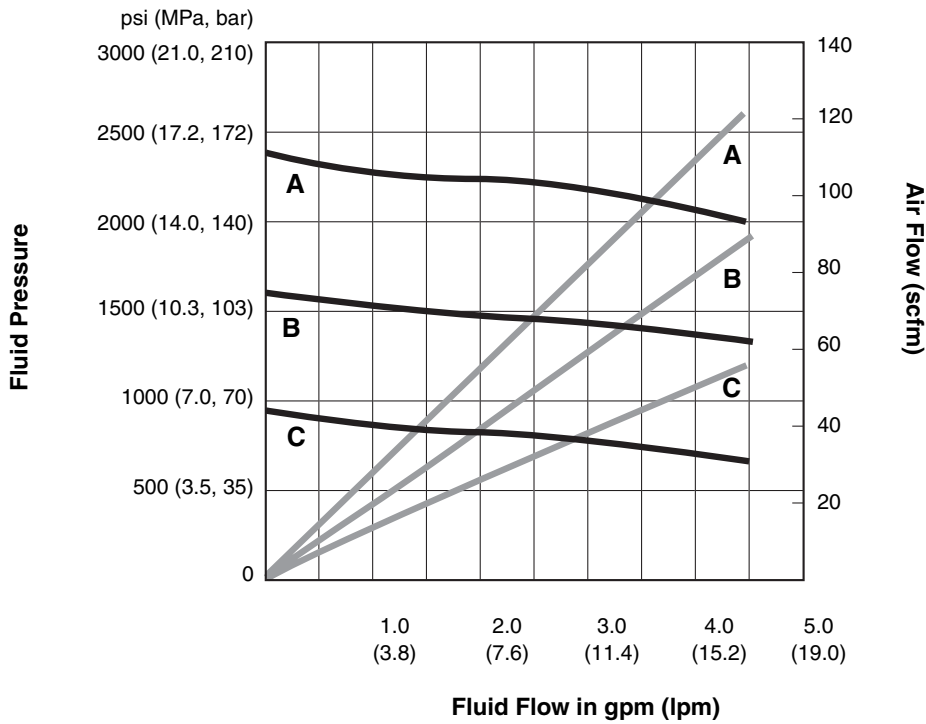

Dura-Flo 1200 Pumps with NXT Model 6500 Air Motors

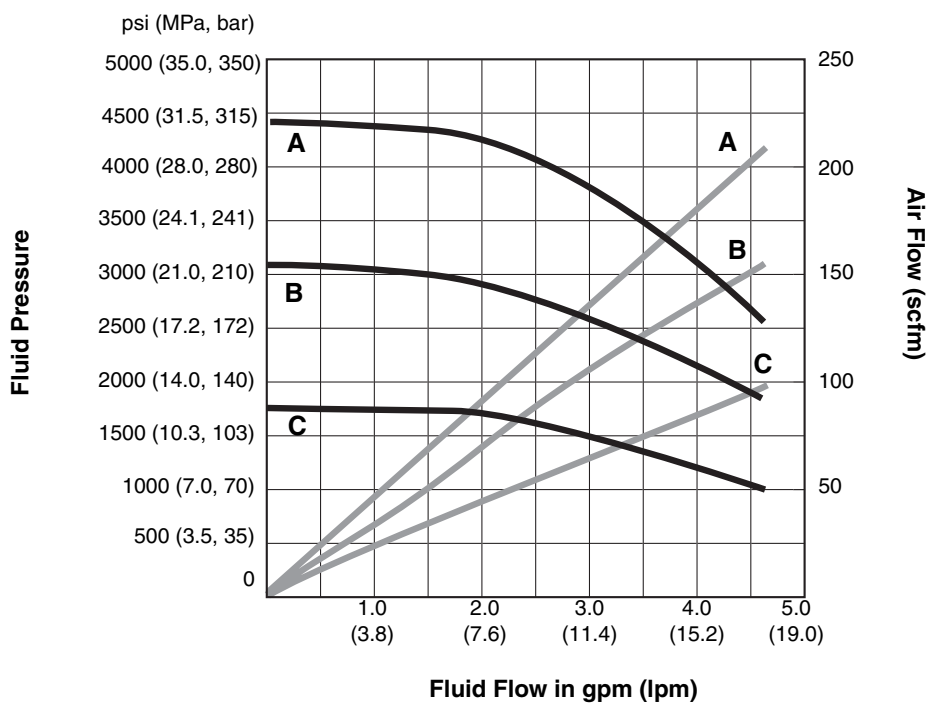

Key

- A** 0.7 MPa, 7 bar (100 psi) air pressure or 10.5 MPa, 105 bar (1500 psi) hydraulic oil pressure
 - B** 0.5 MPa, 4.9 bar (70 psi) air pressure or 7.5 MPa, 75 bar (1050 psi) hydraulic oil pressure
 - C** 0.3 MPa, 2.8 bar (40 psi) air pressure or 4.2 MPa, 42 bar (600 psi) hydraulic oil pressure
- Test Fluid:** No. 10 Weight Oil

Dura-Flo 900 Pumps with Viscount Hydraulic Motors

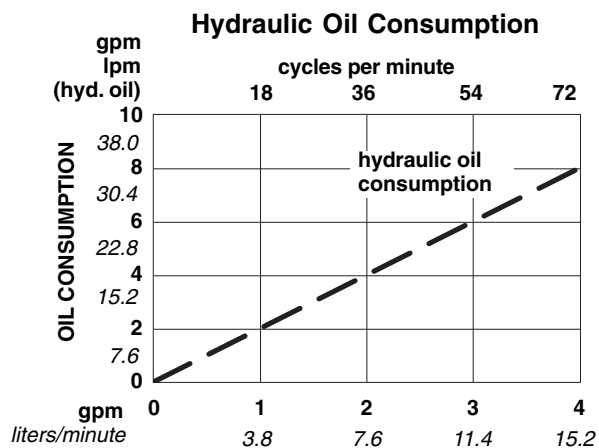
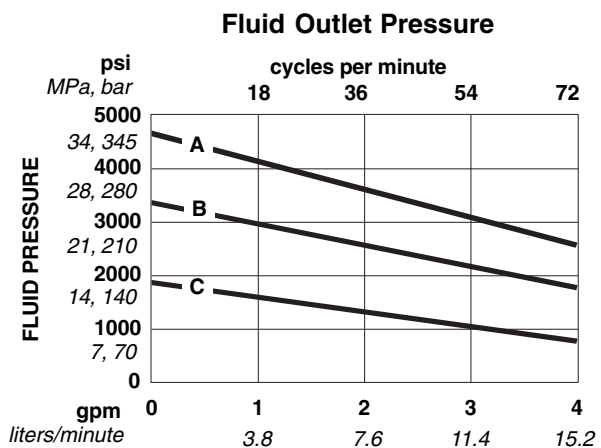

Graco Standard Warranty

Graco warrants all equipment referenced in this document which is manufactured by Graco and bearing its name to be free from defects in material and workmanship on the date of sale to the original purchaser for use. With the exception of any special, extended, or limited warranty published by Graco, Graco will, for a period of twelve months from the date of sale, repair or replace any part of the equipment determined by Graco to be defective. This warranty applies only when the equipment is installed, operated and maintained in accordance with Graco's written recommendations.

This warranty does not cover, and Graco shall not be liable for general wear and tear, or any malfunction, damage or wear caused by faulty installation, misapplication, abrasion, corrosion, inadequate or improper maintenance, negligence, accident, tampering, or substitution of non-Graco component parts. Nor shall Graco be liable for malfunction, damage or wear caused by the incompatibility of Graco equipment with structures, accessories, equipment or materials not supplied by Graco, or the improper design, manufacture, installation, operation or maintenance of structures, accessories, equipment or materials not supplied by Graco.

This warranty is conditioned upon the prepaid return of the equipment claimed to be defective to an authorized Graco distributor for verification of the claimed defect. If the claimed defect is verified, Graco will repair or replace free of charge any defective parts. The equipment will be returned to the original purchaser transportation prepaid. If inspection of the equipment does not disclose any defect in material or workmanship, repairs will be made at a reasonable charge, which charges may include the costs of parts, labor, and transportation.

THIS WARRANTY IS EXCLUSIVE, AND IS IN LIEU OF ANY OTHER WARRANTIES, EXPRESS OR IMPLIED, INCLUDING BUT NOT LIMITED TO WARRANTY OF MERCHANTABILITY OR WARRANTY OF FITNESS FOR A PARTICULAR PURPOSE.

Graco's sole obligation and buyer's sole remedy for any breach of warranty shall be as set forth above. The buyer agrees that no other remedy (including, but not limited to, incidental or consequential damages for lost profits, lost sales, injury to person or property, or any other incidental or consequential loss) shall be available. Any action for breach of warranty must be brought within two (2) years of the date of sale.

GRACO MAKES NO WARRANTY, AND DISCLAIMS ALL IMPLIED WARRANTIES OF MERCHANTABILITY AND FITNESS FOR A PARTICULAR PURPOSE, IN CONNECTION WITH ACCESSORIES, EQUIPMENT, MATERIALS OR COMPONENTS SOLD BUT NOT MANUFACTURED BY GRACO. These items sold, but not manufactured by Graco (such as electric motors, switches, hose, etc.), are subject to the warranty, if any, of their manufacturer. Graco will provide purchaser with reasonable assistance in making any claim for breach of these warranties.

In no event will Graco be liable for indirect, incidental, special or consequential damages resulting from Graco supplying equipment hereunder, or the furnishing, performance, or use of any products or other goods sold hereto, whether due to a breach of contract, breach of warranty, the negligence of Graco, or otherwise.

FOR GRACO CANADA CUSTOMERS

The Parties acknowledge that they have required that the present document, as well as all documents, notices and legal proceedings entered into, given or instituted pursuant hereto or relating directly or indirectly hereto, be drawn up in English. Les parties reconnaissent avoir convenu que la rédaction du présente document sera en Anglais, ainsi que tous documents, avis et procédures judiciaires exécutés, donnés ou intentés, à la suite de ou en rapport, directement ou indirectement, avec les procédures concernées.

Graco Information

TO PLACE AN ORDER, contact your Graco distributor or call to identify the nearest distributor.

Phone: 612-623-6921 **or Toll Free:** 1-800-328-0211 **Fax:** 612-378-3505

*All written and visual data contained in this document reflects the latest product information available at the time of publication.
Graco reserves the right to make changes at any time without notice.*

MM 311828

Graco Headquarters: Minneapolis
International Offices: Belgium, China, Japan, Korea

GRACO INC. P.O. BOX 1441 MINNEAPOLIS, MN 55440-1441

www.graco.com

311828A

11/2006