

High-Flo[®] Pumps

311831 rev.C

Designed for low pressure, high volume circulation of finishing materials. Do not use for flushing or purging lines with caustics, acids, abrasive line strippers, and other similar fluids.



Important Safety Instructions

Read all warnings and instructions in this manual.
Save these instructions.

See page 2 for **Table of Contents** and page 3 for **List of Models**.

Related Manuals	
Part No.	Description
311238	NXT Air Motor manual
308048	Viscount Hydraulic Motor manual
311832	High-Flo Lower manual

Patent Pending

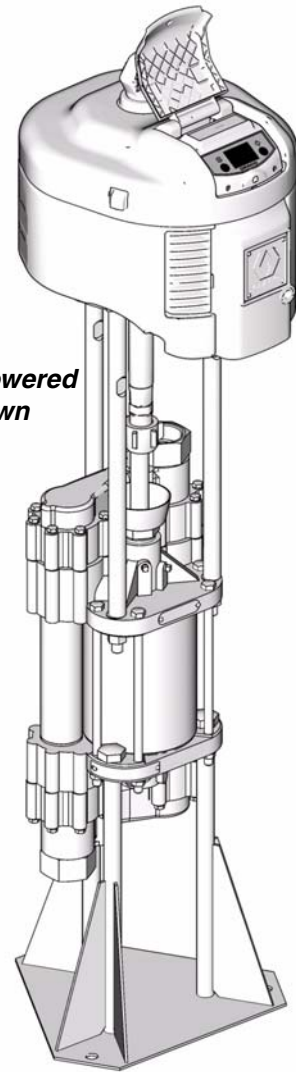

NXT Air-Powered Pump Shown

T18381a

PROVEN QUALITY. LEADING TECHNOLOGY.



Contents

Models	3	Repair	14
NXT Air-Powered Pumps	3	Disconnect the Lower	14
Viscount II Hydraulic-Powered Pumps	3	Reconnect the Lower	14
Warnings	4	Reassemble the Tie Rods to the Motor	15
Installation	6	Parts	16
Grounding	6	NXT Pumps	16
Mount the Pump	6	Common Parts	16
Accessories	6	Parts That Vary by Model	16
Air-Powered Pumps	6	Viscount II Pumps	17
Hydraulic-Powered Pumps	7	Common Parts	17
All Pumps	7	Parts That Vary by Model	17
Plumbing	8	Dimensions	18
Tri-Clamp Adapters	8	Mounting Stand	
Air-Powered Pumps	9	Hole Layout	18
Hydraulic-Powered Pumps	10	Technical Data	19
Operation	11	NXT Air-Powered Pumps	19
Pressure Relief Procedure	11	Performance Charts	19
Flush Before Using Equipment	11	Viscount II 300 Pumps	
Trigger Lock	11	Models 243742, 243755, 243756, 248345,	
Pump Operation	11	248346	21
Maintenance	12	Performance Charts	21
Preventive Maintenance Schedule	12	Viscount II 400 Pumps	
Flushing	12	Models 243741, 243753, 243754, 248344, &	
Air Line Filter	12	248345	22
Hydraulic Power Supply Check	12	Performance Charts 22	
Mix Tank Volume	12	Viscount II 600 Pumps	
Packing Nut Tightness	12	Models 243740, 243751, & 243752	23
Excessive Leaking at Throat	12	Performance Charts	23
Stop the Pump at the Bottom of Its Stroke	12	Graco Standard Warranty	24
Wetcup Maintenance	12	Graco Information	24
Troubleshooting	13		

Models

NXT Air-Powered Pumps

Your model number is marked on the pump identification plate located toward the rear of the air motor. To determine the model number of your pump from the following matrix, select the six digits which describe your pump. The first digit is always J for circulation pumps. The remaining five digits define the construction. For example, a circulation pump with stainless steel construction, a 3.3:1 ratio, low noise exhaust, no communication option, npt fittings, and chrome rod and cylinder is model number **J S 33 L 1**. To order replacement parts, see page 16.





J	S	33				L			1		
First Digit	Second Digit	Third and Fourth Digit				Fifth Digit			Sixth Digit		
	Material	Motor Size	Lower Size	Maximum Fluid Pressure psi (MPa, bar)	Exhaust	Communication		Fittings	Rod	Cylinder	
J (all circulation pumps)	C Carbon Steel	33	6500	4000	330 (2.3, 23)	L Low Noise	none		1 npt	Plasma-coat	Chrome
	S Stainless Steel	44	6500	3000	440 (2.8, 28)	M Low Noise	DataTrak™		3 bspp	Plasma-coat	Chrome
		60	6500	2000	500 (3.4, 34)	R Remote	none				
			XX = X.X:1 ratio			S Remote	DataTrak™				

Viscount II Hydraulic-Powered Pumps

Model No.	Series	Maximum Pump Working Pressure psi (MPa, bar)	Connection Style	Material	Rod Material	Cylinder Material	High-Flo Lower (see manual 311832)
243740	B	500 (3.5, 35)	npt	CS	Plasmacoat	Chrome	243731
243741	B	400 (2.8, 28)	npt	CS	Plasmacoat	Chrome	243732
243742	B	300 (2.1, 21)	npt	CS	Plasmacoat	Chrome	243733
243751	B	500 (3.5, 35)	npt	SST	Plasmacoat	Chrome	243734
243752	B	500 (3.5, 35)	bspp	SST	Plasmacoat	Chrome	243734
243753	B	400 (2.8, 28)	npt	SST	Plasmacoat	Chrome	243735
243754	B	400 (2.8, 28)	bspp	SST	Plasmacoat	Chrome	243735
243755	B	300 (2.1, 21)	npt	SST	Plasmacoat	Chrome	243736
243756	B	300 (2.1, 21)	bspp	SST	Plasmacoat	Chrome	243736
248343	A	400 (2.8, 28)	npt	SST	Chrome	Chrome	248330
248344	A	400 (2.8, 28)	bspp	SST	Chrome	Chrome	248330
248345	A	300 (2.1, 21)	npt	SST	Chrome	Chrome	248331
248346	A	300 (2.1, 21)	bspp	SST	Chrome	Chrome	248331

Warnings

The following warnings are for the setup, use, grounding, maintenance, and repair of this equipment. The exclamation point symbol alerts you to a general warning and the hazard symbol refers to procedure-specific risk. Refer back to these warnings. Additional, product-specific warnings may be found throughout the body of this manual where applicable.

 WARNING	
	<p>EQUIPMENT MISUSE HAZARD</p> <p>Misuse can cause death or serious injury.</p> <ul style="list-style-type: none"> • Do not operate the unit when fatigued or under the influence of drugs or alcohol. • Do not exceed the maximum working pressure or temperature rating of the lowest rated system component. See Technical Data in all equipment manuals. • Use fluids and solvents that are compatible with equipment wetted parts. See Technical Data in all equipment manuals. Read fluid and solvent manufacturer's warnings. For complete information about your material, request MSDS forms from distributor or retailer. • Check equipment daily. Repair or replace worn or damaged parts immediately with genuine manufacturer's replacement parts only. • Do not alter or modify equipment. • Use equipment only for its intended purpose. Call your distributor for information. • Route hoses and cables away from traffic areas, sharp edges, moving parts, and hot surfaces. • Do not kink or over bend hoses or use hoses to pull equipment. • Keep children and animals away from work area. • Comply with all applicable safety regulations.
	<p>FIRE AND EXPLOSION HAZARD</p> <p>Flammable fumes, such as solvent and paint fumes, in work area can ignite or explode. To help prevent fire and explosion:</p> <ul style="list-style-type: none"> • Use equipment only in well ventilated area. • Eliminate all ignition sources; such as pilot lights, cigarettes, portable electric lamps, and plastic drop cloths (potential static arc). • Keep work area free of debris, including solvent, rags and gasoline. • Do not plug or unplug power cords, or turn power or light switches on or off when flammable fumes are present. • Ground all equipment in the work area. See Grounding instructions. • Use only grounded hoses. • Hold gun firmly to side of grounded pail when triggering into pail. • If there is static sparking or you feel a shock, stop operation immediately. Do not use equipment until you identify and correct the problem. • Keep a working fire extinguisher in the work area.
	<p>TOXIC FLUID OR FUMES HAZARD</p> <p>Toxic fluids or fumes can cause serious injury or death if splashed in the eyes or on skin, inhaled, or swallowed.</p> <ul style="list-style-type: none"> • Read MSDS's to know the specific hazards of the fluids you are using. • Store hazardous fluid in approved containers, and dispose of it according to applicable guidelines. • Always wear impervious gloves when spraying or cleaning equipment.



WARNING



MOVING PARTS HAZARD

Moving parts can pinch or amputate fingers and other body parts.

- Keep clear of moving parts.
- Do not operate equipment with protective guards or covers removed.
- Pressurized equipment can start without warning. Before checking, moving, or servicing equipment, follow the **Pressure Relief Procedure** in this manual. Disconnect power or air supply.

Installation

Grounding

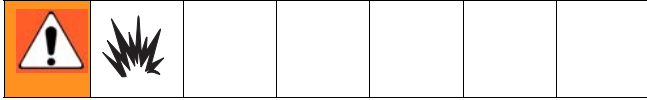

The equipment must be grounded. Grounding reduces the risk of static and electric shock by providing an escape wire for the electrical current due to static build up or in the event of a short circuit.

Pump: use a ground wire and clamp. Remove the green ground screw (Z) from the bottom of the air motor. Insert the screw through the loop on the end of the ground wire (Y) and reattach the screw to the air motor. Connect the ground clamp to a true earth ground. See FIG. 1.

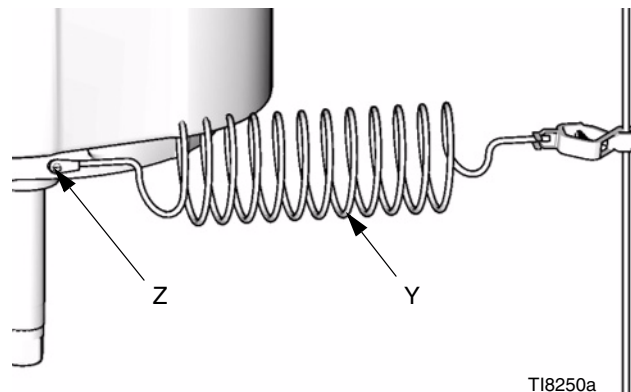

FIG. 1

Air and fluid hoses: use only electrically conductive hoses with a maximum of 500 ft. (150 m) combined hose length to ensure grounding continuity. Check the electrical resistance of hoses. If total resistance to ground exceeds 29 megohms, replace hose immediately.

Air compressor: follow manufacturer's recommendations.

Hydraulic power supply: follow manufacturer's recommendations.

Surge tank: use a ground wire and clamp.

Spray gun: ground through a connection to a properly grounded fluid hose and pump.

Fluid supply container: follow local code.

Object being sprayed: follow local code.

Solvent pails used when flushing: follow local code. Use only conductive metal pails, placed on a grounded surface. Do not place the pail on a nonconductive surface, such as paper or cardboard, which interrupts grounding continuity.

To maintain grounding continuity when flushing or relieving pressure: hold metal part of the spray gun firmly to the side of a grounded metal pail, then trigger the gun.

Mount the Pump

Mount the pump in the accessory pump stand (A), Part 218742. Secure the stand to the floor with M19 (5/8 in.) bolts which engage at least 152 mm (6 in.) into the concrete floor to prevent the pump from tipping.

Accessories

Install the following accessories in the order shown in FIG. 3 and FIG. 4, using adapters as necessary.



 Accessory Air Control Kits are available for the NXT Air Motor. The kits include a master air valve, air regulator, and filter. Order the kit separately. Use kit NXT031 for the derated J_60__ pumps (75 psi maximum air input pressure). See manual 311239 for more information.

Air-Powered Pumps



For typical installation, see FIG. 3 on page 9.

Air Line

- **Bleed-type master air valve (M):** required in your system to relieve air trapped between it and the air motor when the valve is closed.

						
Trapped air can cause the pump to cycle unexpectedly, which could result in serious injury from splashing or moving parts.						

Be sure the valve is easily accessible from the pump and located downstream from the air regulator. Be sure the air bleed hole points away from the operator.

						
<p>The air motor is rated to 100 psi (0.7 MPa, 7.0 bar). If you will apply more than 100 psi (0.7 MPa, 7.0 bar) to the system, install a safety relief valve between the bleed-type master air valve and the air motor.</p>						

- **Pump air regulator (L):** to control pump speed and outlet pressure. Locate close to the pump.
- **Air line filter (K):** removes harmful dirt and moisture from compressed air supply.
- **Second bleed-type air valve (M):** isolates air line accessories for servicing. Locate upstream from all other air line accessories.

Hydraulic-Powered Pumps

For typical installation, see FIG. 4 on page 10.

Hydraulic Power Supply

CAUTION	
<p>The hydraulic power supply must be kept clean at all times to avoid damage to the motor and hydraulic power supply.</p>	
1.	Blow out hydraulic lines with air and flush thoroughly before connection to the motor.
2.	Plug hydraulic inlets, outlets, and line ends when disconnecting them for any reason.

Be sure the power supply can provide sufficient power to the motor. Be sure the power supply is equipped with a suction filter to the hydraulic pump.

Hydraulic Supply Line

 The hydraulic inlet on the motor is 3/4 in. npt. Use a minimum 1/2 in. (13 mm) ID hydraulic supply line (R).

- **Supply line shutoff valve (H):** isolates the motor when servicing the system. See FIG. 4.
- **Hydraulic fluid pressure gauge (J):** monitors the hydraulic oil pressure to the motor to avoid over-pressurizing the motor or lower.

- **Pressure- and temperature-compensated flow control valve (K):** prevents the motor from running too fast, which can damage it.
- **Pressure reducing valve (L), which has a drain line (M) running to the return line (S):** controls the hydraulic pressure to the motor.

Hydraulic Return Line

 The hydraulic outlet on the motor is 1 in. npt. Use a minimum 5/8 in. (16 mm) ID hydraulic return line (S).

- **Return line shutoff valve (N):** isolates the motor when servicing the system.



CAUTION	
<p>To avoid damage to the pump, never use the return line shutoff valve to control the hydraulic flow. Do not install any flow control devices on the hydraulic return line.</p>	

- **Return fluid filter (J):** removes residue from the hydraulic fluid to help keep the system running smoothly (10 micron size).

All Pumps

Fluid Line

- **Fluid filter:** with a 60 mesh (250 micron) stainless steel element to filter particles from the fluid as it leaves the pump.
- **Fluid drain valve (T):** required in your system, to relieve fluid pressure in the hose and gun.

						
---	--	--	--	--	--	--

- **Fluid shutoff valve (D):** shuts off fluid flow.
- **Fluid pressure regulator:** for more precise adjustment of the fluid pressure.
- **Gun or valve:** to dispense fluid.
- **Fluid line swivel:** for easier gun movement.
- **Suction kit:** enables the pump to draw fluid from a container.

Plumbing

The lowers have a 2 in. npt(f) fluid inlet and a 2 in. npt(f) fluid outlet or a 2 in. bspp(f) and a 2 in. bspp(f) fluid outlet.

Use 2 in. (50 mm) diameter pipe and plumbing. Install a fluid shutoff valve (D) between each tank and the pump.

When using a stainless steel pump, use stainless steel plumbing to maintain a corrosion-resistant system.

Tri-Clamp Adapters

Tri-clamp adapters are available which allow sanitary pipe to be connected to a pump with bspp inlet and outlet. Refer to FIG. 2.

Install a 2 in. tri-clamp gasket (AA) in the groove of the tri-clamp adapter (BB). Mate the tri-clamp adapter with the sanitary pipe and secure with two clamps (CC), bolts (DD), and nuts (EE). Install the bolts in opposite directions.

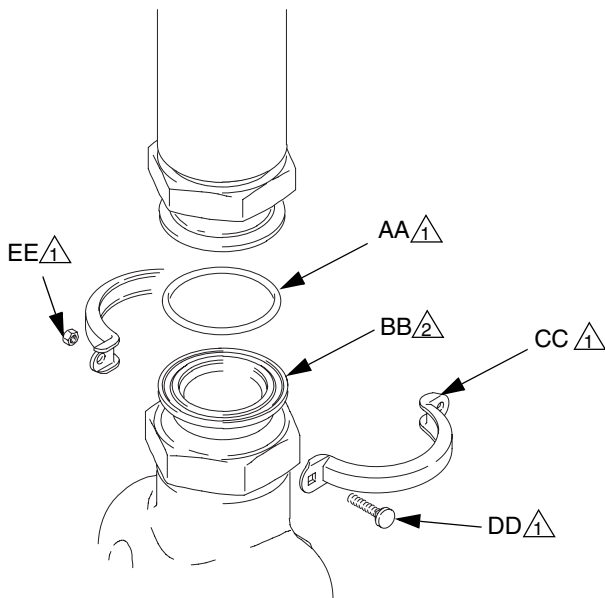

8689a

△₁ Customer must supply.

△₂ Graco adapter 193202. Requires seal 193424.

FIG. 2

Air-Powered Pumps

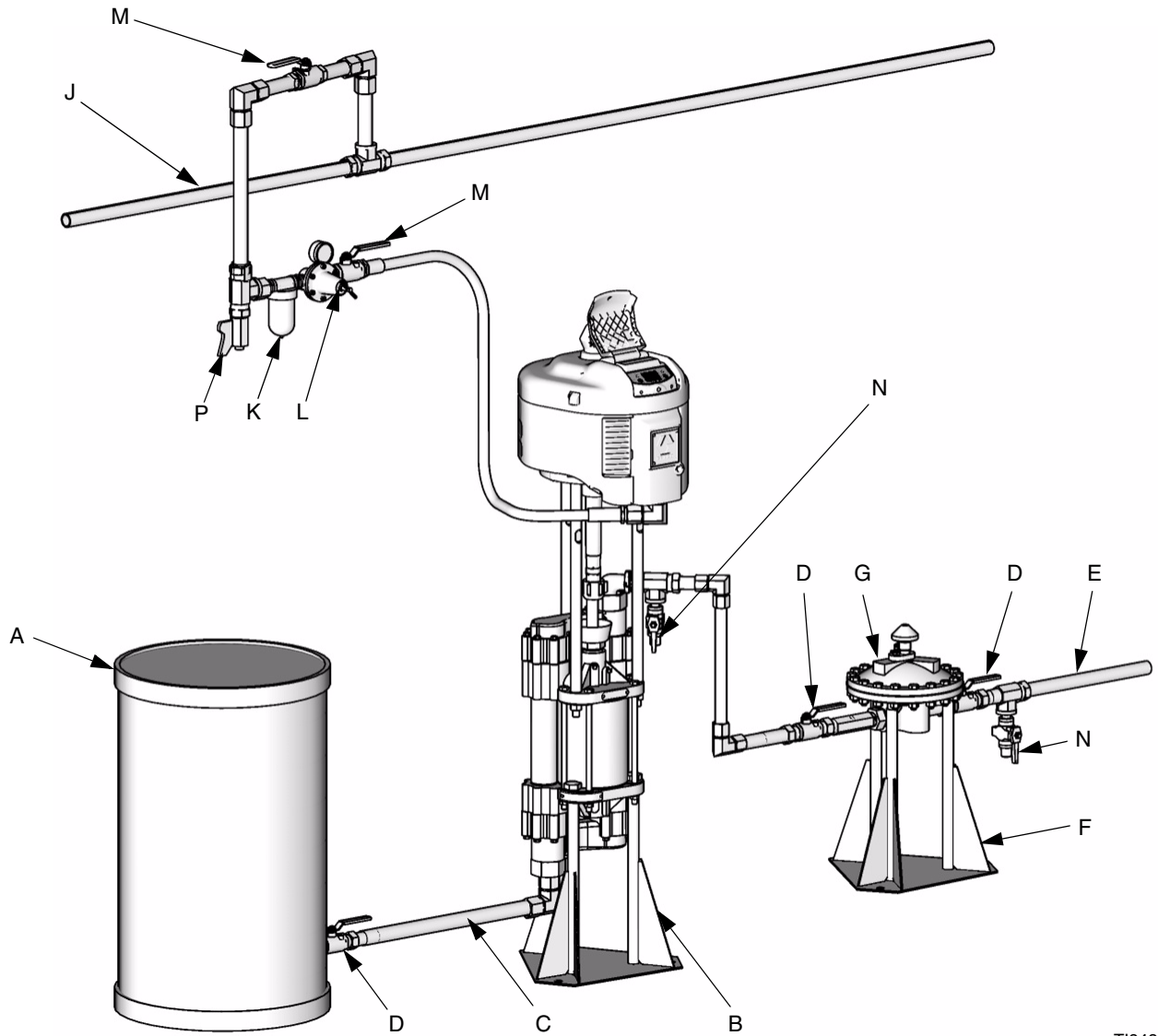

TI8435a

FIG. 3: Typical Installation

Key:

- A Mix Tank
- B Pump Stand
- C Fluid Supply Line; 2 in. (50 mm) minimum diameter
- D Fluid Shutoff Valve
- E Fluid Line
- F Surge Tank Stand
- G Surge Tank
- J Air Supply Line
- K Air Line Filter
- L Air Regulator and Gauge
- M Bleed-Type Master Air Valve
- N Fluid Drain Valve
- P Air Line Drain Valve

Hydraulic-Powered Pumps

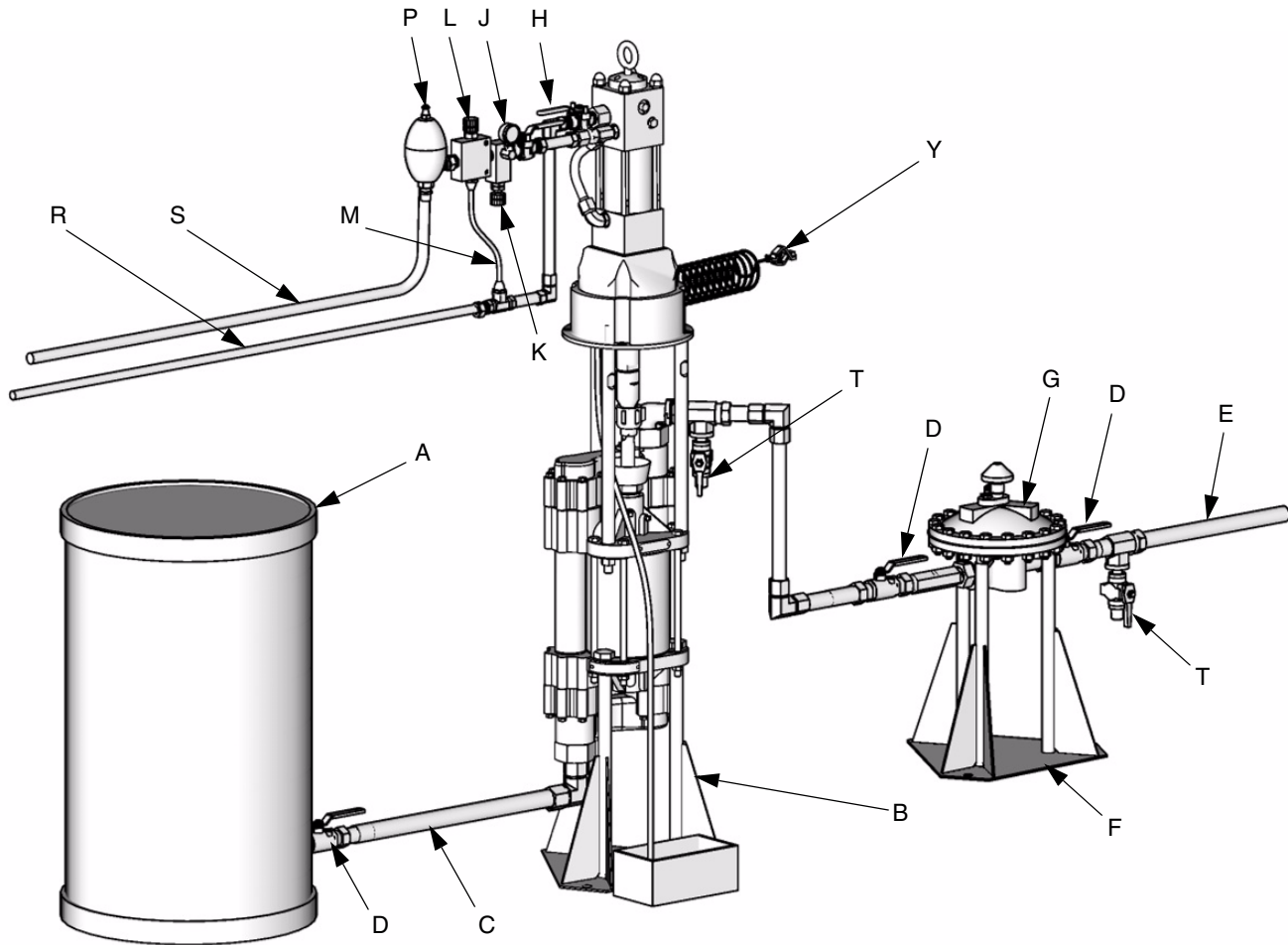

T18436a

FIG. 4: Typical Installation

Key:

- A Mix Tank
- B Pump Stand
- C Fluid Supply Line; 2 in. (50 mm) minimum diameter
- D Fluid Shutoff Valve
- E Fluid Line
- F Surge Tank Stand
- G Surge Tank
- H Hydraulic Supply Line Shutoff Valve
- J Hydraulic Pressure Gauge
- K Flow Control Valve
- L Pressure Reducing Valve
- M Drain Line
- N Hydraulic Return Line Shutoff Valve
- P Accumulator
- R Hydraulic Return Line
- S Hydraulic Supply Line
- T Fluid Drain Valve
- Y Ground Wire

Operation

Pressure Relief Procedure



1. Engage trigger lock.
2. *Air-Powered Pumps only:* Close the bleed-type master air valve.

Hydraulic-Powered Pumps only: Shut off the hydraulic supply line valve (H) first, then the return line valve (N).
3. Disengage the trigger lock.
4. Hold a metal part of the gun firmly to a grounded metal pail. Trigger the gun to relieve pressure.
5. Engage the trigger lock.
6. Open all fluid drain valves in the system, having waste containers ready to catch drainage. Leave the drain valves open until you are ready to spray again.
7. If you suspect the spray tip or hose is clogged or that pressure has not been fully relieved after following the steps above, **VERY SLOWLY** loosen the tip guard retaining nut or hose end coupling to relieve pressure gradually, then loosen completely. Clear hose or tip obstruction.

CAUTION
<i>Hydraulic-Powered Pumps only:</i> When shutting down the hydraulic system, always shut off the hydraulic supply line shutoff valve (H) first, and then the return line shutoff valve (N) to prevent overpressurizing the motor or its seals. When starting the hydraulic system, open the return line shutoff valve first.

Flush Before Using Equipment

The equipment was tested with lightweight oil, which is left in the fluid passages to protect parts. To avoid contaminating your fluid with oil, flush the equipment with a compatible solvent before using the equipment. See **Flushing**, page 12.

Trigger Lock

Always engage the trigger lock when you stop spraying to prevent the gun from being triggered accidentally by hand or if dropped or bumped.

Pump Operation



In a circulation system, the pump operates continuously until the power supply is shut off.

In a direct-supply system, the pump starts when the gun is opened, and stops when the gun is closed.

Perform a stall test periodically to ensure the piston seal is in good working condition and prevent system overpressurization:

Close the fluid shutoff valve (D) closest to the pump on the downstroke and be sure that the pump stalls. Open the fluid shutoff valve to restart the pump. Close the fluid shutoff valve (D) closest to the pump on the upstroke and be sure that the pump stalls.

CAUTION
Do not allow the pump to run quickly for a long period of time as this may damage the packings.

Stop the pump on the downstroke, before the air motor changes over.

CAUTION
Failure to stop the pump at the bottom of its stroke allows fluid to dry on the piston rod, which can damage the throat packings when the pump is restarted.

Hydraulic-Powered Pumps only: Always shut off the supply line shutoff valve (H) first, and then the return line shutoff valve (N). This is to prevent overpressurizing the motor or its seals.

Maintenance

Preventive Maintenance Schedule

The operating conditions of your particular system determine how often maintenance is required. Establish a preventive maintenance schedule by recording when and what kind of maintenance is needed, and then determine a regular schedule for checking your system. Your maintenance schedule should include the following:

Flushing

- Flush before shutting down the system for an extended period of time.
- Flush before repairing the pump, if possible.
- Flush before fluid can dry out, settle, or set up in the equipment.

Air Line Filter

Drain and clean as necessary.

Hydraulic Power Supply Check

Carefully follow the hydraulic power supply manufacturer's recommendations on reservoir and filter cleaning, and periodic changes of hydraulic fluid.

Mix Tank Volume

Don't let the mix tank run dry. When the tank is empty, the pump demands more power as it tries to suck in some fluid. This causes the pump to run too fast, which can seriously damage the pump.

Packing Nut Tightness

Check the packing nut (21) tightness every few days at startup and then weekly throughout the life of the seal. The packing nut should be tight enough to stop leakage, but no tighter. See FIG. 5.

To check the adjustment of the packing nut, stop the pump and relieve fluid pressure. Loosen the packing nut until it turns freely. Tighten the nut firmly and then turn the nut another 1/4 turn. If you have a torque wrench, tighten the packing nut to 20-25 ft-lb (27-34 N•m).

Excessive Leaking at Throat

If you see excessive leaking at the throat, tighten the packing nut (21), see FIG. 5. If this does not fix the problem, replace the throat packings, piston rod, or both. See manual 311832.

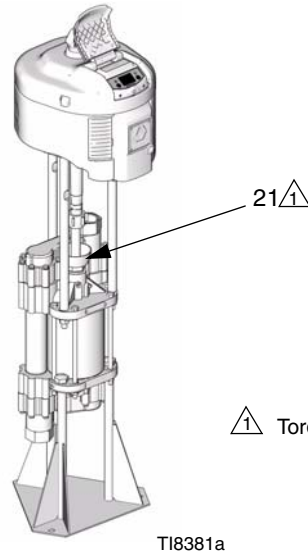

NXT Air-Powered Pump Shown

FIG. 5

Stop the Pump at the Bottom of Its Stroke

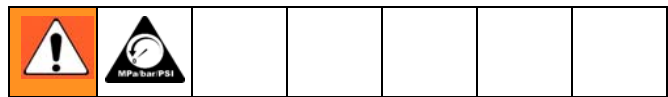

Relieve the pressure when you stop the pump for any reason. Stop the pump on the downstroke, before the air motor changes over.

CAUTION

Failure to stop the pump at the bottom of its stroke allows fluid to dry on the piston rod, which can cause damage to the throat packings when the pump is restarted.

Wetcup Maintenance

Fill the wetcup/packing nut (12) one-half full with Graco Throat Seal Liquid (TSL). Maintain level daily.

Troubleshooting

					
<p>To reduce the risk of serious injury whenever you are instructed to relieve pressure, always follow the Pressure Relief Procedure on page 15.</p>					

1. Relieve the pressure.
2. Check all possible problems and solutions before disassembling pump.

PROBLEM	CAUSE	SOLUTION
Pump output low on both strokes.	Restricted air or hydraulic supply lines.	Clear any obstructions; be sure all shutoff valve are open; increase pressure, but do not exceed maximum working pressure.
	Exhausted fluid supply.	Refill and reprime pump.
	Clogged fluid outlet line, valves, etc.	Clear.
	Worn piston packing.	Replace. See lower manual 311832.
Pump output low on only one stroke.	Held open or worn ball check valves.	Check and repair.
	Worn piston packings.	Replace. See lower manual 311832.
No output.	Improperly installed ball check valves.	Check and repair.
Pump operates erratically.	Exhausted fluid supply.	Refill and reprime pump.
	Held open or worn ball check valves.	Check and repair.
	Worn piston packing.	Replace. See lower manual 311832.
	Excessive hydraulic fluid supply pressure to Viscount motor.	See Viscount motor manual 308048.
Pump will not operate.	Restricted air or hydraulic supply lines.	Clear any obstructions; be sure all shut off valves are open; increase pressure, but do not exceed maximum working pressure.
	Exhausted fluid supply.	Refill and reprime pump.
	Clogged fluid outlet line, valves, etc.	Clear.
	Damaged air motor or hydraulic motor.	See air motor manual 311238 or hydraulic motor manual 308330.
	Fluid dried on piston rod (17).	Disassemble and clean pump. See lower manual 311832. In future, stop pump at bottom of stroke.

Repair

-  To service the lower, see manual 311832.
- To service the air motor, see manual 311238.
- To service the hydraulic motor, see manual 308048.

Disconnect the Lower

To service the lower, follow the procedure on this page, and disassemble the lower as described in manual 311832.

-  In stand or wall-mounted installations, you do not have to remove the entire pump from its mounting.

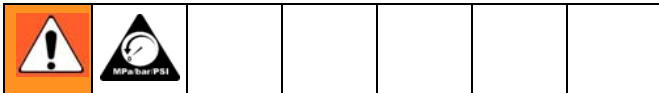

1. Relieve the pressure, see Pressure Relief Procedure page 11.
2. Disconnect the hoses from the lower and plug the ends to prevent fluid contamination.
3. Loosen the coupling nut (K) and remove the collars (G). Remove the coupling nut from the piston rod (H). Unscrew the locknuts (B) from the tie rods (C). Pull the motor (E) off the lower (D). See FIG. 6 and FIG. 7.

Reconnect the Lower

-  If the tie rods (C) have been disassembled from the motor, see Reassemble the Tie Rods to the Motor on page 15.

1. Assemble the coupling nut (K) to the piston rod (H).
2. Orient the lower (D) to the motor (E). Position the lower on the tie rods (C). Lubricate the threads of the tie rods. Screw the tie rod locknuts (B) onto the tie rods. Tighten the locknuts and torque to 50-60 ft-lb (68-81 N•m).

3. Insert the collars (G) into the coupling nut (K). Tighten the coupling nut onto the piston rod (H) and torque to 145-155 ft-lb (196-210 N•m).
4. Flush and test the pump before reinstalling it in the system. Connect hoses and flush the pump. While it is pressurized, check for smooth operation and leaks. Adjust or repair as necessary before reinstalling in the system. Reconnect the pump ground wire before operating.

NXT Air-Powered Pump Shown

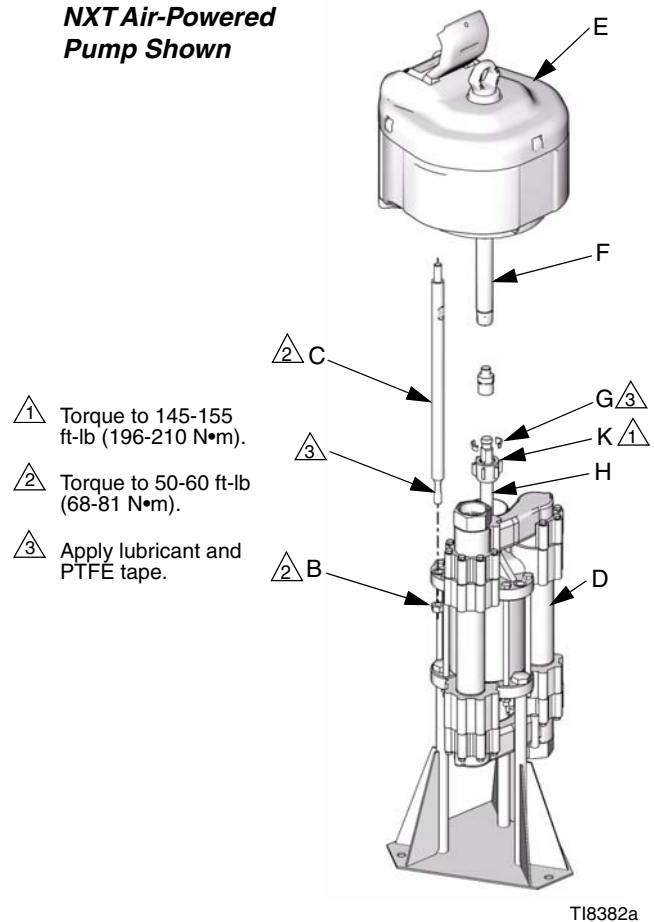

FIG. 6

T18382a

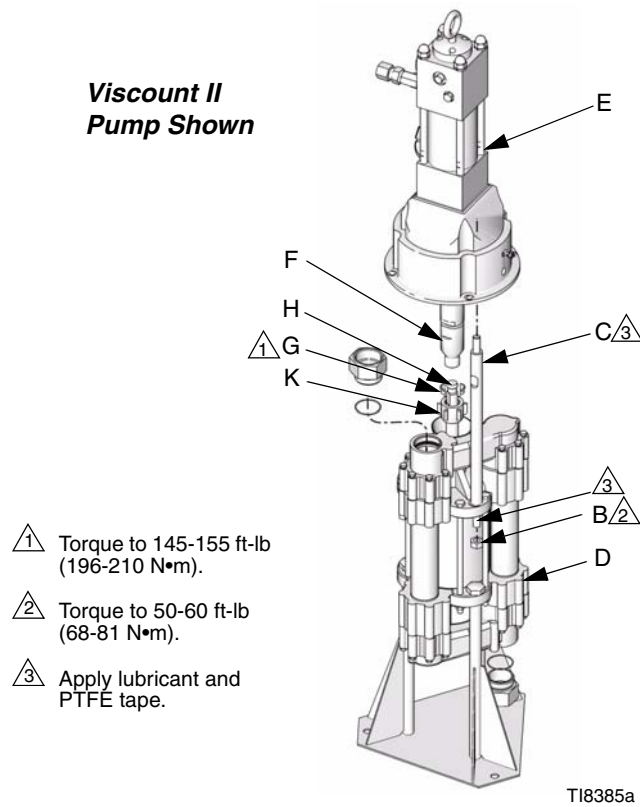



FIG. 7

Reassemble the Tie Rods to the Motor

 Use this procedure only if the tie rods (C) have been disassembled from the motor.

Screw the tie rods (C) into the base of the motor and torque to 50-60 ft-lb (68-81 N•m).

Parts

NXT Pumps

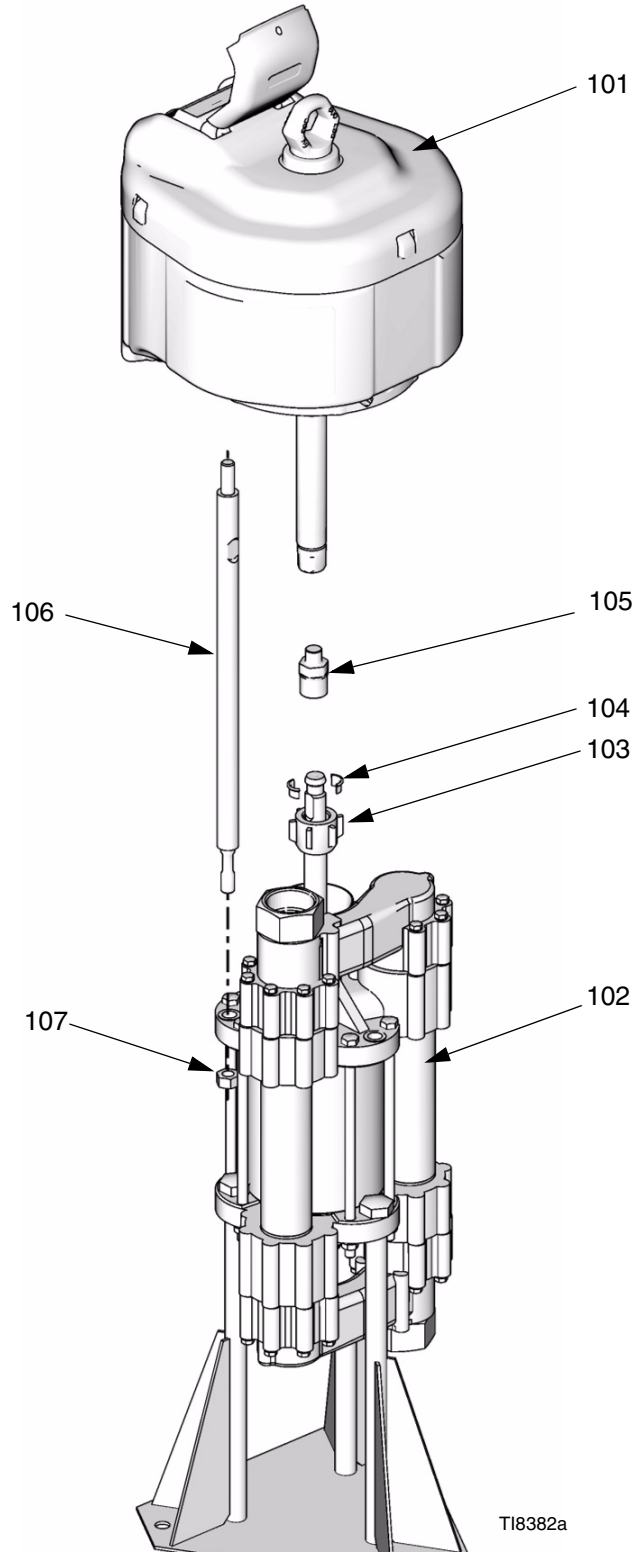

Common Parts

Ref. No.	Description	Part No.	Qty.
101	MOTOR, NXT, see manual 311238	see table, below	1
102	LOWER, High-Flo, see manual 311690	see table, below	1
103	NUT, coupling	186925	1
104	COLLAR, coupling	184129	2
105	ADAPTER, coupling	15H370	1
106	TIE ROD, 19.307 in. (490.398 mm) between shoulders	15H600	3
107	NUT, lock, hex; 5/8-11	102216	3

Parts That Vary by Model

	101	102
Air-Powered Pump (see page 3)	NXT Air Motor (see manual 311238)	High-Flo Lower (see manual 311832)
JC33L1	N65LNO	243733
JC33M1	N65LTO	243733
JC44L1	N65LNO	243732
JC44M1	N65LTO	243732
JC60L1	N65LNO	243731
JC60M1	N65LTO	243731
JS33L1	N65LNO	243773
JS33L3	N65LNO	243736
JS33M1	N65LTO	243773
JS33M3	N65LTO	243736
JS33R1	N65RNO	243773
JS33R3	N65RNO	243736
JS33S1	N65RTO	243773
JS33S3	N65RTO	243736
JS44L1	N65LNO	243772
JS44L3	N65LNO	243735
JS44M1	N65LTO	243772
JS44M3	N65LTO	243735
JS44R1	N65RNO	243772
JS44R3	N65RNO	243735
JS44S1	N65RTO	243772
JS44S3	N65RTO	243735
JS60L1	N65LNO	243771
JS60L3	N65LNO	243734
JS60M1	N65LTO	243771
JS60M3	N65LTO	243734
JS60R1	N65RNO	243771
JS60R3	N65RNO	243734
JS60S1	N65RTO	243771
JS60S3	N65RTO	243734

Viscount II Pumps

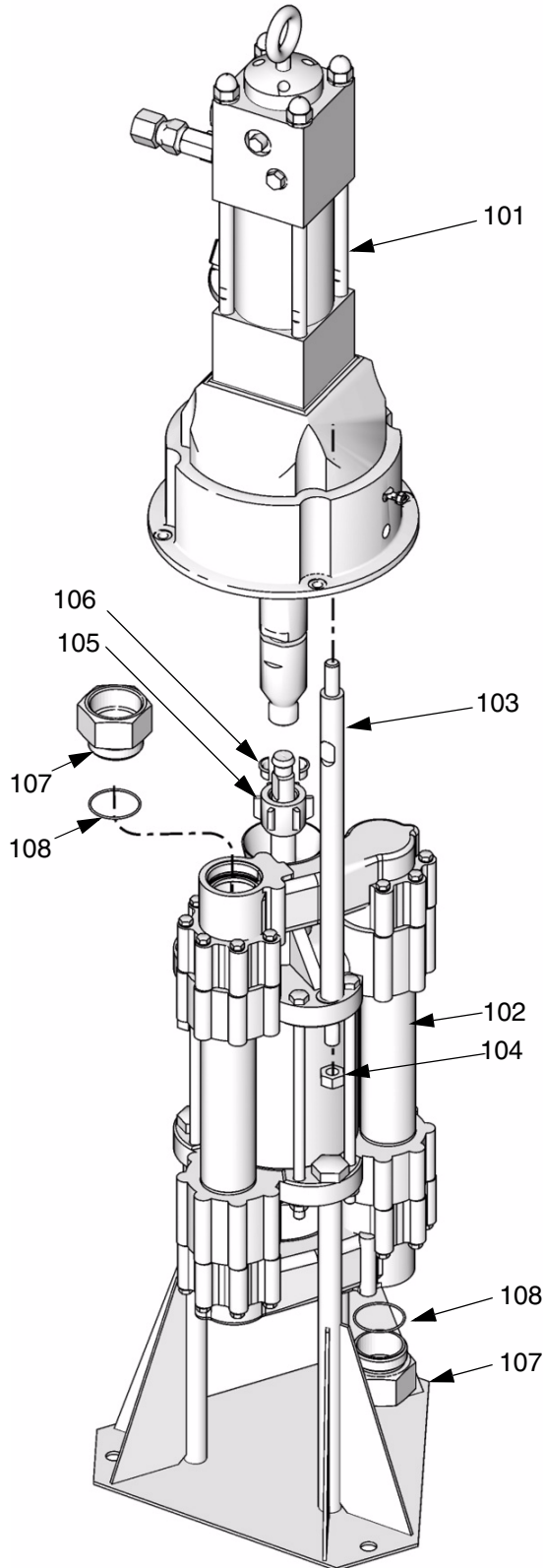

Common Parts

Ref. No.	Description	Part No.	Qty.
101	MOTOR, Viscount II, see manual 308048	223646	1
102	LOWER, High-Flo, see manual 311832	see table, below	1
103	TIE ROD, 12.72 in. (323 mm) between shoulders	180487	3
104	NUT, lock, hex; 5/8-11	102216	3
105	NUT, coupling	186925	1
106	COLLAR, coupling	184129	2
107	ADAPTER, coupling; 2 in. npt; 2 in. bspp	see table, below	1
108	SEAL, 2 in. bspp	see table, below	1

Parts That Vary by Model

	102	107	108
Hydraulic-Powered Pump (see page 3)	High-Flo Lower (see manual 311832)	Adapter	Seal
243740	243731	none	none
243741	243732	none	none
243742	243733	none	none
243751	243734	196321	193424
243752	243734	none	none
243753	243735	196321	193424
243754	243735	none	none
243755	243736	196321	193424
243756	243736	none	none
248343	248330	196321	193424
248344	248330	none	none
248345	248331	196321	193424
248346	248331	none	none

T18385a

Dimensions

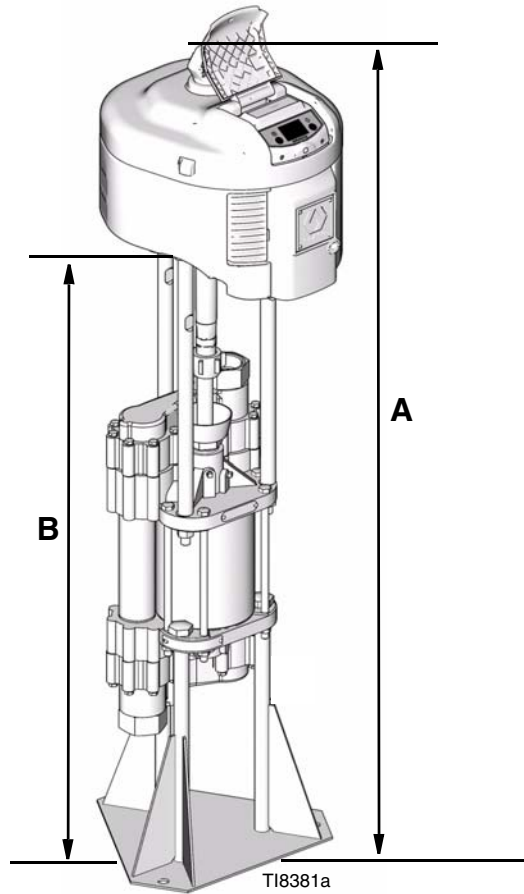

Mounting Stand Hole Layout

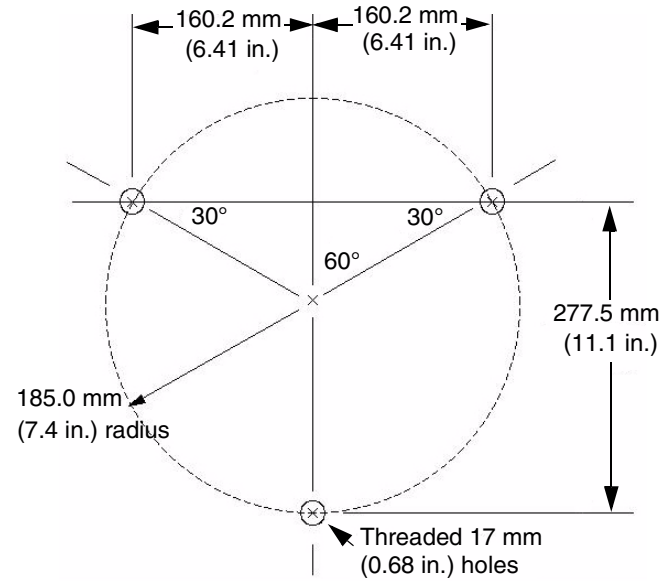

Air-Powered Pumps

Pump Model	A in. (mm)	B in. (mm)	Approx. Weight lb (kg)
NXT cs	51.4 (1306)	35.5 (901)	180 (81.8)
NXT sst	51.4 (1306)	35.5 (901)	180 (81.8)
NXT severe-duty sst	51.4 (1306)	35.5 (901)	180 (81.8)

Hydraulic-Powered Pumps

Pump Model	A in. (mm)	B in. (mm)	Approx. Weight lb (kg)
Viscount I+ cst	64.9 (1649)	39.3 (998)	217 (98.4)
Viscount I+ sst	64.9 (1649)	39.3 (998)	217 (98.4)
Viscount I+ severe-duty sst	64.9 (1649)	39.3 (998)	217 (98.4)

Technical Data

NXT Air-Powered Pumps

Model	Maximum Working Pressure psi (MPa, bar)	Maximum Air Input Pressure psi (MPa, bar)	Air Consumption	Fluid Flow at 60 cycles per minute gpm (lpm)	Pump Cycles per Gallon (Liter)	Maximum Fluid Temperature Rating °F (°C)
JX33XX	330 (2.3, 23)	100 (0.7, 7.0)	See Performance Charts	63 (237)	0.93 (0.24)	150° (66°)
JX44XX	440 (3.0, 30)	100 (0.7, 7.0)		47 (178)	1.3 (0.34)	
JX60XX	500 (3.4, 34)	75 (0.52, 5.2)		31 (118)	1.93 (0.5)	

Performance Charts

To find Fluid Outlet Pressure (psi/MPa/bar) at a specific fluid flow (lpm/gpm) and operating hydraulic pressure (psi/MPa/bar):

1. Locate desired flow along bottom of chart.
2. Follow vertical line up to intersection with selected fluid outlet pressure curve (black). Follow left to scale to read fluid outlet pressure.

Key

- A** 0.5 MPa, 4.9 bar (70 psi) air pressure
 - B** 0.37 MPa, 3.7 bar (55 psi) air pressure
 - C** 0.3 MPa, 2.8 bar (40 psi) air pressure
- Test Fluid: No. 10 Weight Oil

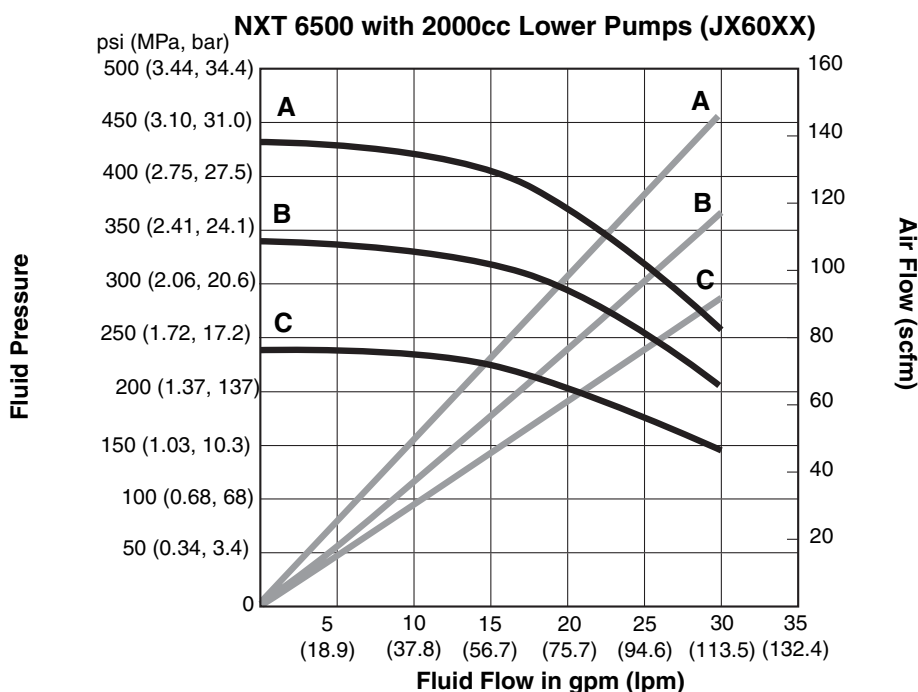

Key

- A** 0.7 MPa, 7 bar (100 psi) air pressure
 - B** 0.5 MPa, 4.9 bar (70 psi) air pressure
 - C** 0.3 MPa, 2.8 bar (40 psi) air pressure
- Test Fluid:** No. 10 Weight Oil

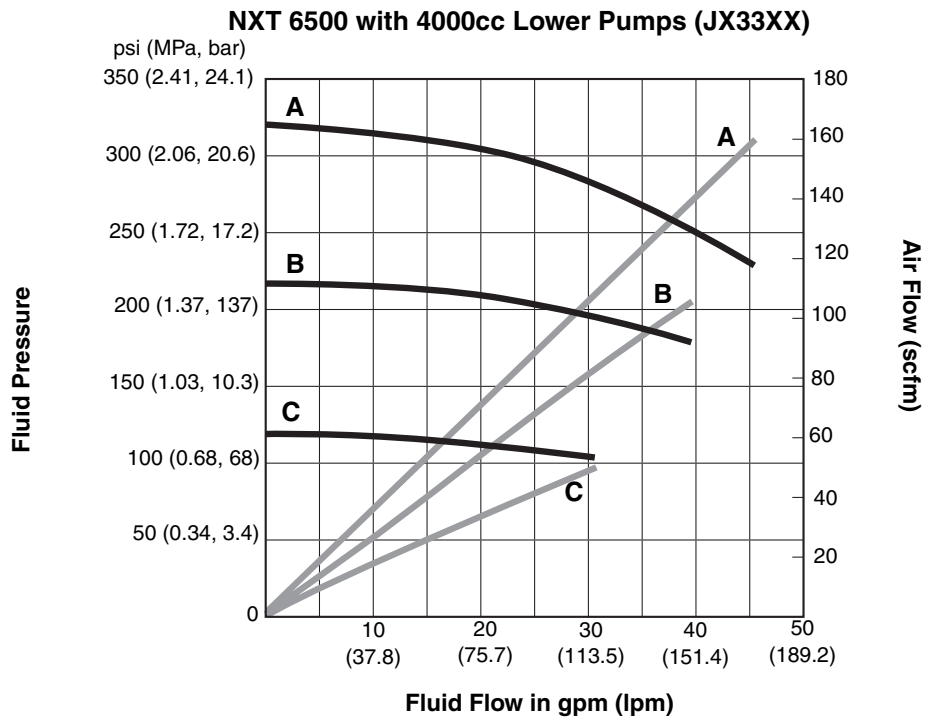
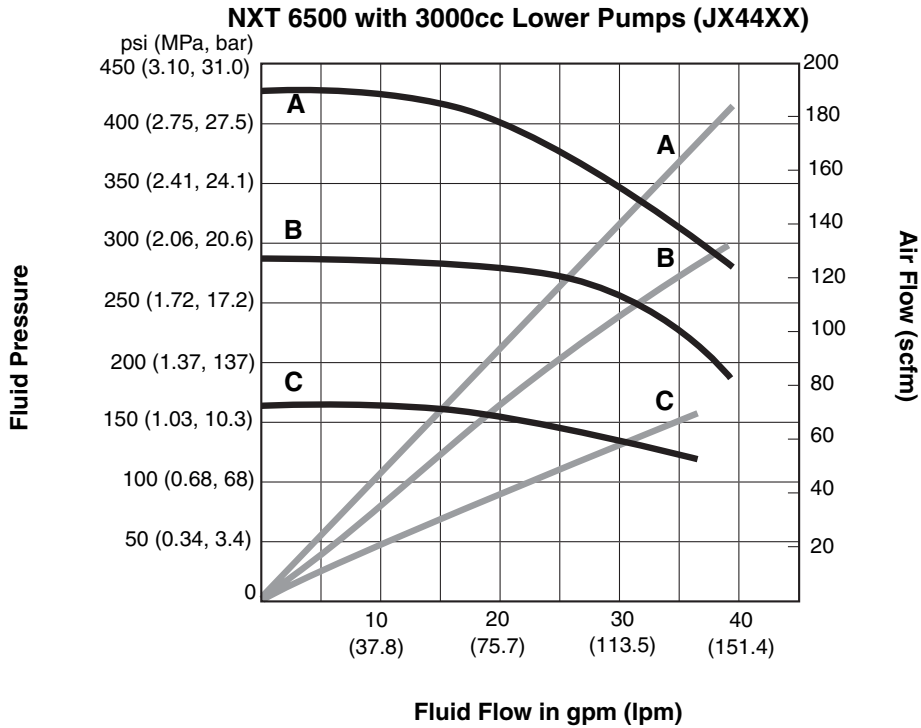

Viscount II 300 Pumps

Models 243742, 243755, 243756, 248345, 248346

Category	Data
Maximum Fluid Working Pressure	2.1 MPa 21 bar (300 psi)
Maximum Hydraulic Fluid Pressure	10.3 MPa, 103 bar (1500 psi)
Fluid Flow at 60 Cycles per Minute	237 liters/min (63 gpm)
Cycles Per Liter (gallon)	0.24 (0.93)
Maximum Recommended Pump Speed	60 cycles per minute
Maximum Hydraulic Motor Fluid Temperature	54°C (134°F)
Wetted Parts	<p><i>Model 243742:</i> Carbon Steel, Stainless Steel, PTFE, Ultra High Molecular Weight Polyethylene</p> <p><i>Models 243755, 243756, 248345, & 248346:</i> Stainless Steel, PTFE, Ultra High Molecular Weight Polyethylene</p>

Performance Charts

To find Fluid Outlet Pressure (psi/MPa/bar) at a specific fluid flow (lpm/gpm) and operating hydraulic pressure (psi/MPa/bar):

1. Locate desired flow along bottom of chart.
2. Follow vertical line up to intersection with selected fluid outlet pressure curve (black). Follow left to scale to read fluid outlet pressure.

To find Motor Hydraulic Oil Consumption (l/min. or gpm) at a specific fluid flow (l/min. or gpm):

1. Locate desired flow along bottom of chart.
2. Read vertical line up to intersection with hydraulic oil consumption curve (dashes). Follow left to scale to read hydraulic oil consumption.

- A** 10.3 MPa, 103 bar (1500 psi) hydraulic pressure
- B** 7.2 MPa, 72.4 bar (1050 psi) hydraulic pressure
- C** 4.1 MPa, 41 bar (600 psi) hydraulic pressure

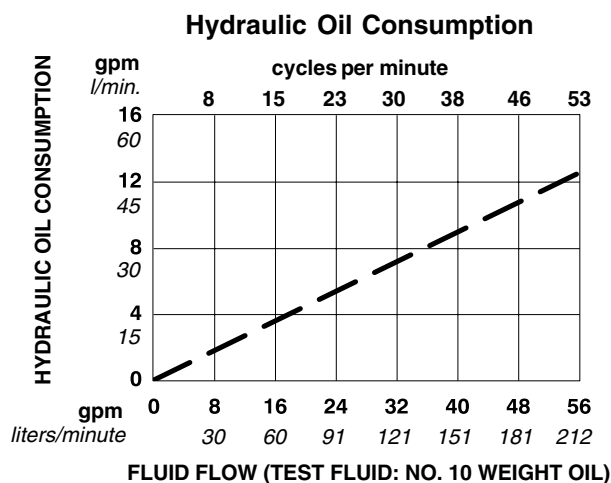
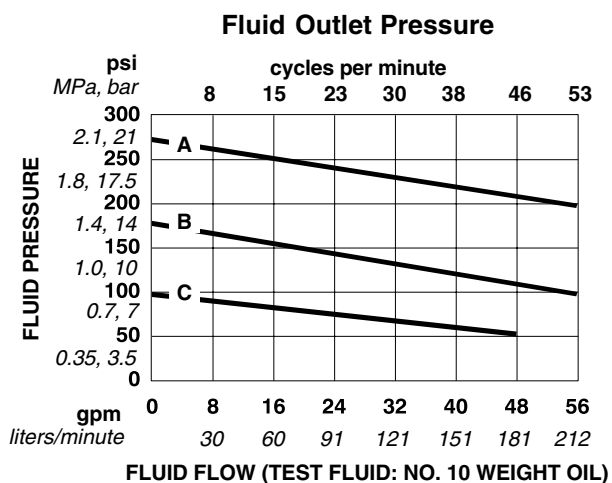

Viscount II 400 Pumps

Models 243741, 243753, 243754, 248344, & 248345

Category	Data
Maximum Fluid Working Pressure	2.8 MPa, 28 bar (400 psi)
Maximum Hydraulic Fluid Pressure	10.3 MPa, 103 bar (1500 psi)
Fluid Flow at 60 Cycles per Minute	178 liter/min (47 gpm)
Cycles Per Liter (gallon)	0.34 (1.3)
Maximum Recommended Pump Speed	60 cycles per minute
Maximum Hydraulic Motor Fluid Temperature	54°C (134°F)
Wetted parts	<p><i>Model 243741:</i> Carbon Steel, Stainless Steel, PTFE Ultra High Molecular Weight Polyethylene</p> <p><i>Models 243753, 243754, 248344, & 248345:</i> Stainless Steel, PTFE, Ultra High Molecular Weight Polyethylene</p>

Performance Charts

To find Fluid Outlet Pressure (psi/MPa/bar) at a specific fluid flow (lpm/gpm) and operating hydraulic pressure (psi/MPa/bar):

1. Locate desired flow along bottom of chart.
2. Follow vertical line up to intersection with selected fluid outlet pressure curve (black). Follow left to scale to read fluid outlet pressure.

To find Motor Hydraulic Oil Consumption (l/min. or gpm) at a specific fluid flow (l/min. or gpm):

1. Locate desired flow along bottom of chart.
2. Read vertical line up to intersection with hydraulic oil consumption curve (dashes). Follow left to scale to read hydraulic oil consumption.

- A** 10.3 MPa, 103 bar (1500 psi) hydraulic pressure
- B** 7.2 MPa, 72.4 bar (1050 psi) hydraulic pressure
- C** 4.1 MPa, 41 bar (600 psi) hydraulic pressure

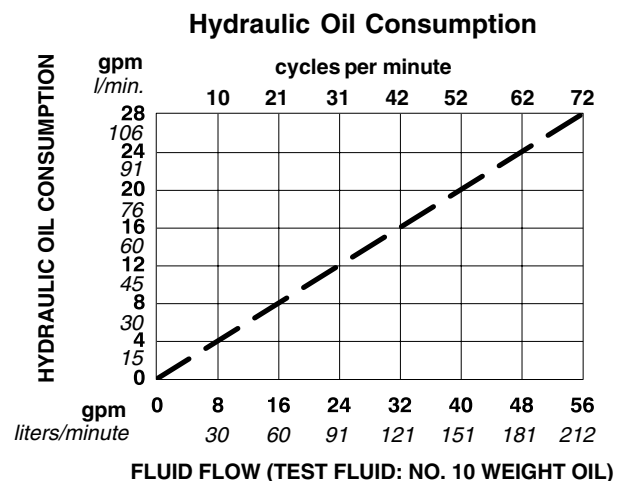
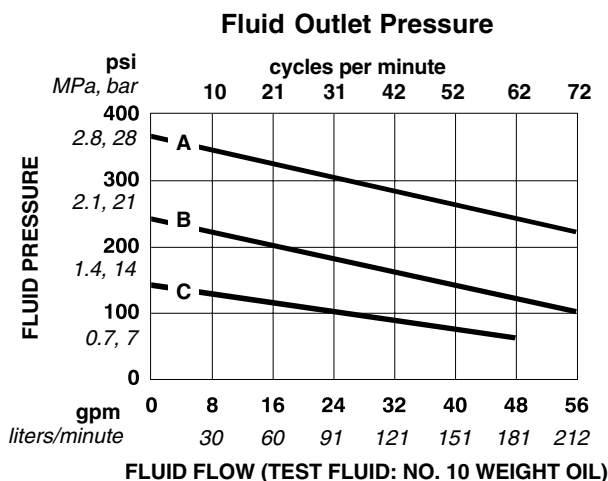

Viscount II 600 Pumps Models 243740, 243751, & 243752

Category	Data
Maximum Fluid Working Pressure	4.1 MPa, 41 bar (600 psi)
Maximum Hydraulic Fluid Pressure	10.3 MPa, 103 bar (1500 psi)
Fluid Flow at 60 Cycles per Minute	118 liter/min (31 gpm)
Cycles Per Liter (gallon)	0.5 (1.93)
Maximum Recommended Pump Speed	60 cycles per minute
Maximum Hydraulic Motor Fluid Temperature	54°C (134°F)
Wetted parts	<p><i>Model 243740:</i> Carbon Steel, Stainless Steel, PTFE, Ultra High Molecular Weight Polyethylene</p> <p><i>Models 243751 and 243752:</i> Stainless Steel, PTFE, Ultra High Molecular Weight Polyethylene</p>

Performance Charts

To find Fluid Outlet Pressure (psi/MPa/bar) at a specific fluid flow (lpm/gpm) and operating hydraulic pressure (psi/MPa/bar):

1. Locate desired flow along bottom of chart.
2. Follow vertical line up to intersection with selected fluid outlet pressure curve (black). Follow left to scale to read fluid outlet pressure.

To find Motor Hydraulic Oil Consumption (l/min. or gpm) at a specific fluid flow (l/min. or gpm):

1. Locate desired flow along bottom of chart.
2. Read vertical line up to intersection with hydraulic oil consumption curve (dashes). Follow left to scale to read hydraulic oil consumption.

A 10.3 MPa, 103 bar (1500 psi) hydraulic pressure

B 7.2 MPa, 72.4 bar (1050 psi) hydraulic pressure

C 4.1 MPa, 41 bar (600 psi) hydraulic pressure

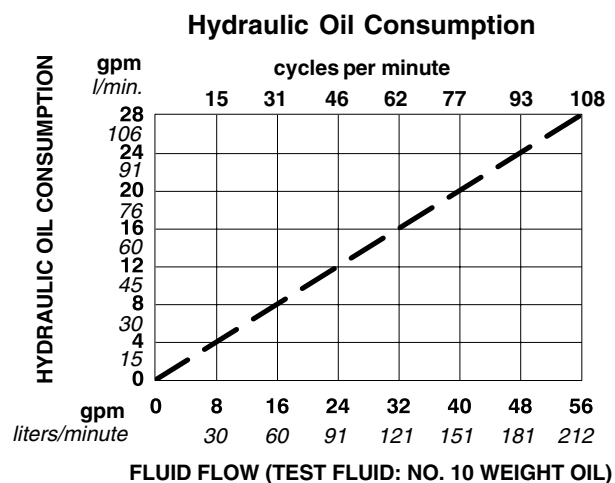
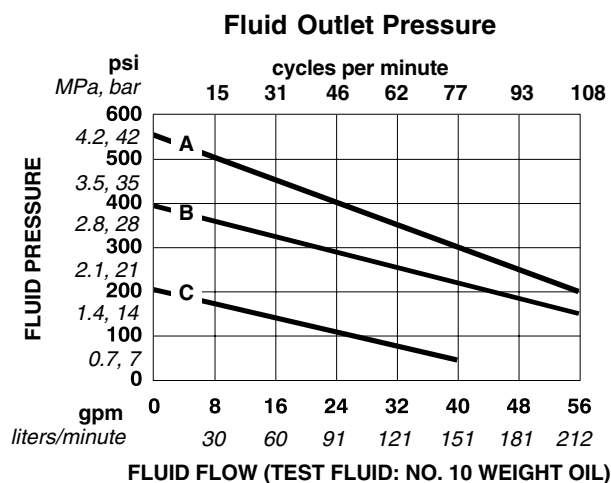

Graco Standard Warranty

Graco warrants all equipment referenced in this document which is manufactured by Graco and bearing its name to be free from defects in material and workmanship on the date of sale to the original purchaser for use. With the exception of any special, extended, or limited warranty published by Graco, Graco will, for a period of twelve months from the date of sale, repair or replace any part of the equipment determined by Graco to be defective. This warranty applies only when the equipment is installed, operated and maintained in accordance with Graco's written recommendations.

This warranty does not cover, and Graco shall not be liable for general wear and tear, or any malfunction, damage or wear caused by faulty installation, misapplication, abrasion, corrosion, inadequate or improper maintenance, negligence, accident, tampering, or substitution of non-Graco component parts. Nor shall Graco be liable for malfunction, damage or wear caused by the incompatibility of Graco equipment with structures, accessories, equipment or materials not supplied by Graco, or the improper design, manufacture, installation, operation or maintenance of structures, accessories, equipment or materials not supplied by Graco.

This warranty is conditioned upon the prepaid return of the equipment claimed to be defective to an authorized Graco distributor for verification of the claimed defect. If the claimed defect is verified, Graco will repair or replace free of charge any defective parts. The equipment will be returned to the original purchaser transportation prepaid. If inspection of the equipment does not disclose any defect in material or workmanship, repairs will be made at a reasonable charge, which charges may include the costs of parts, labor, and transportation.

THIS WARRANTY IS EXCLUSIVE, AND IS IN LIEU OF ANY OTHER WARRANTIES, EXPRESS OR IMPLIED, INCLUDING BUT NOT LIMITED TO WARRANTY OF MERCHANTABILITY OR WARRANTY OF FITNESS FOR A PARTICULAR PURPOSE.

Graco's sole obligation and buyer's sole remedy for any breach of warranty shall be as set forth above. The buyer agrees that no other remedy (including, but not limited to, incidental or consequential damages for lost profits, lost sales, injury to person or property, or any other incidental or consequential loss) shall be available. Any action for breach of warranty must be brought within two (2) years of the date of sale.

GRACO MAKES NO WARRANTY, AND DISCLAIMS ALL IMPLIED WARRANTIES OF MERCHANTABILITY AND FITNESS FOR A PARTICULAR PURPOSE, IN CONNECTION WITH ACCESSORIES, EQUIPMENT, MATERIALS OR COMPONENTS SOLD BUT NOT MANUFACTURED BY GRACO. These items sold, but not manufactured by Graco (such as electric motors, switches, hose, etc.), are subject to the warranty, if any, of their manufacturer. Graco will provide purchaser with reasonable assistance in making any claim for breach of these warranties.

In no event will Graco be liable for indirect, incidental, special or consequential damages resulting from Graco supplying equipment hereunder, or the furnishing, performance, or use of any products or other goods sold hereto, whether due to a breach of contract, breach of warranty, the negligence of Graco, or otherwise.

FOR GRACO CANADA CUSTOMERS

The Parties acknowledge that they have required that the present document, as well as all documents, notices and legal proceedings entered into, given or instituted pursuant hereto or relating directly or indirectly hereto, be drawn up in English. Les parties reconnaissent avoir convenu que la rédaction du présente document sera en Anglais, ainsi que tous documents, avis et procédures judiciaires exécutés, donnés ou intentés, à la suite de ou en rapport, directement ou indirectement, avec les procédures concernées.

Graco Information

TO PLACE AN ORDER, contact your Graco distributor or call to identify the nearest distributor.

Phone: 612-623-6921 **or Toll Free:** 1-800-328-0211 **Fax:** 612-378-3505

*All written and visual data contained in this document reflects the latest product information available at the time of publication.
Graco reserves the right to make changes at any time without notice.*

This manual contains English. MM 311831

Graco Headquarters: Minneapolis

International Offices: Belgium, China, Japan, Korea

GRACO INC. P.O. BOX 1441 MINNEAPOLIS, MN 55440-1441

www.graco.com

11/2006 Rev. 4/2007