



# High-Flo<sup>®</sup> Lowers

311832 rev.A

*Designed for low pressure, high volume circulation of finishing materials.  
Intended for use with High-Flo<sup>®</sup> pumps.*



**Important Safety Instructions**

Read all warnings and instructions in your High-Flo Pump manual 311831. Save these instructions.

See page 2 for **List of Models**.

Patent Pending

## Contents

<b>Models</b> .....	<b>3</b>
2000cc Lowers .....	3
3000cc Lowers .....	3
4000cc Lowers .....	3
<b>Warnings</b> .....	<b>4</b>
<b>Repair</b> .....	<b>6</b>
Grounding .....	6
Pressure Relief Procedure .....	6
Dissassembly .....	7
Reassembly .....	9
<b>Lower Parts</b> .....	<b>14</b>
2000cc Lowers .....	15
3000cc Lowers .....	16
4000cc Lowers .....	17
<b>Repair and Conversion Kits</b> .....	<b>19</b>
<b>Graco Standard Warranty</b> .....	<b>20</b>
<b>Graco Information</b> .....	<b>20</b>

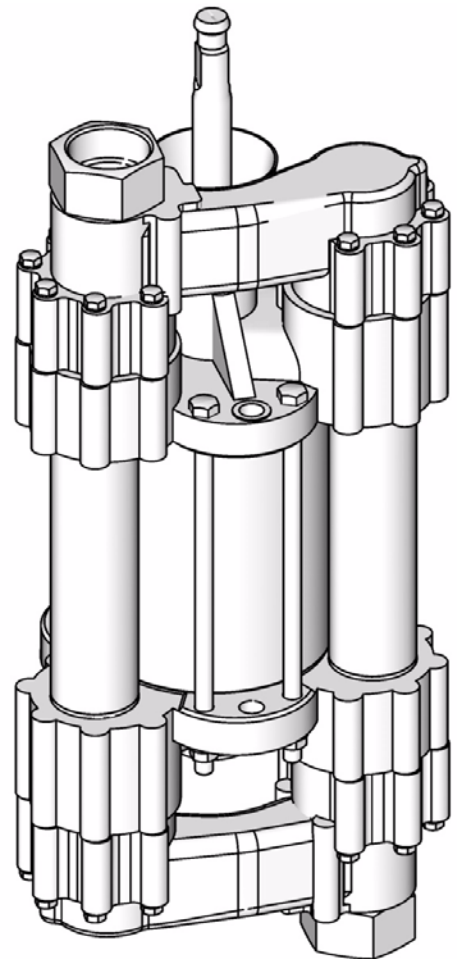

T18339a

PROVEN QUALITY. LEADING TECHNOLOGY.



A series of 25 horizontal lines spanning the width of the page, providing a template for writing.

# Models

## 2000cc Lowers

Model No.	Series	Material	Size (cc)	Maximum Pump Working Pressure psi (MPa, bar)	Rod Material	Cylinder Material	Fitting Style	Parts Page
243731	D	CST	2000	500 (3.5, 35)	Plasma-coat	Chrome	NPT	15
243734	D	SST	2000	500 (3.5, 35)	Plasma-coat	Chrome	BSPP	15
243771	D	SST	2000	500 (3.5, 35)	Plasma-coat	Chrome	NPT	15
248329	B	SST	2000	500 (3.5, 35)	Chrome	Chrome	BSPP	15
248332	B	SST	2000	500 (3.5, 35)	Chrome	Chrome	NPT	15

## 3000cc Lowers





Model No.	Series	Material	Size (cc)	Maximum Pump Working Pressure psi (MPa, bar)	Rod Material	Cylinder Material	Fitting Style	Parts Page
243732	D	CST	3000	440 (3.0, 30)	Plasma-coat	Chrome	NPT	16
243735	D	SST	3000	440 (3.0, 30)	Plasma-coat	Chrome	BSPP	16
243772	D	SST	3000	440 (3.0, 30)	Plasma-coat	Chrome	NPT	16
248330	B	SST	3000	440 (3.0, 30)	Chrome	Chrome	BSPP	16
248333	B	SST	3000	440 (3.0, 30)	Chrome	Chrome	NPT	16

## 4000cc Lowers

Model No.	Series	Material	Size (cc)	Maximum Pump Working Pressure psi (MPa, bar)	Rod Material	Cylinder Material	Fitting Style	Parts Page
243733	D	CST	4000	330 (2.3, 23)	Plasma-coat	Chrome	NPT	17
243736	D	SST	4000	330 (2.3, 23)	Plasma-coat	Chrome	BSPP	17
243773	D	SST	4000	330 (2.3, 23)	Plasma-coat	Chrome	NPT	17
248331	B	SST	4000	330 (2.3, 23)	Chrome	Chrome	BSPP	17
248334	B	SST	4000	330 (2.3, 23)	Chrome	Chrome	NPT	17

# Warnings

The following warnings are for the setup, use, grounding, maintenance, and repair of this equipment. The exclamation point symbol alerts you to a general warning and the hazard symbol refers to procedure-specific risk. Refer back to these warnings. Additional, product-specific warnings may be found throughout the body of this manual where applicable.

 <b>WARNING</b>	
	<p><b>FIRE AND EXPLOSION HAZARD</b></p> <p>Flammable fumes, such as solvent and paint fumes, in work area can ignite or explode. To help prevent fire and explosion:</p> <ul style="list-style-type: none"> <li>• Use equipment only in well ventilated area.</li> <li>• Eliminate all ignition sources; such as pilot lights, cigarettes, portable electric lamps, and plastic drop cloths (potential static arc).</li> <li>• Keep work area free of debris, including solvent, rags and gasoline.</li> <li>• Do not plug or unplug power cords, or turn power or light switches on or off when flammable fumes are present.</li> <li>• Ground all equipment in the work area. See <b>Grounding</b> instructions.</li> <li>• Use only grounded hoses.</li> <li>• Hold gun firmly to side of grounded pail when triggering into pail.</li> <li>• If there is static sparking or you feel a shock, <b>stop operation immediately</b>. Do not use equipment until you identify and correct the problem.</li> <li>• Keep a working fire extinguisher in the work area.</li> </ul>
	<p><b>PRESSURIZED EQUIPMENT HAZARD</b></p> <p>Fluid from the gun/dispense valve, leaks, or ruptured components can splash in the eyes or on skin and cause serious injury.</p> <ul style="list-style-type: none"> <li>• Follow <b>Pressure Relief Procedure</b> in this manual, when you stop spraying and before cleaning, checking, or servicing equipment.</li> <li>• Tighten all fluid connections before operating the equipment.</li> <li>• Check hoses, tubes, and couplings daily. Replace worn or damaged parts immediately.</li> </ul>
	<p><b>EQUIPMENT MISUSE HAZARD</b></p> <p>Misuse can cause death or serious injury.</p> <ul style="list-style-type: none"> <li>• Do not operate the unit when fatigued or under the influence of drugs or alcohol.</li> <li>• Do not exceed the maximum working pressure or temperature rating of the lowest rated system component. See <b>Technical Data</b> in all equipment manuals.</li> <li>• Use fluids and solvents that are compatible with equipment wetted parts. See <b>Technical Data</b> in all equipment manuals. Read fluid and solvent manufacturer's warnings. For complete information about your material, request MSDS forms from distributor or retailer.</li> <li>• Check equipment daily. Repair or replace worn or damaged parts immediately with genuine manufacturer's replacement parts only.</li> <li>• Do not alter or modify equipment.</li> <li>• Use equipment only for its intended purpose. Call your distributor for information.</li> <li>• Route hoses and cables away from traffic areas, sharp edges, moving parts, and hot surfaces.</li> <li>• Do not kink or over bend hoses or use hoses to pull equipment.</li> <li>• Keep children and animals away from work area.</li> <li>• Comply with all applicable safety regulations.</li> </ul>

**WARNING**
**MOVING PARTS HAZARD**

Moving parts can pinch or amputate fingers and other body parts.

- Keep clear of moving parts.
- Do not operate equipment with protective guards or covers removed.
- Pressurized equipment can start without warning. Before checking, moving, or servicing equipment, follow the **Pressure Relief Procedure** in this manual. Disconnect power or air supply.

**TOXIC FLUID OR FUMES HAZARD**

Toxic fluids or fumes can cause serious injury or death if splashed in the eyes or on skin, inhaled, or swallowed.

- Read MSDS's to know the specific hazards of the fluids you are using.
- Store hazardous fluid in approved containers, and dispose of it according to applicable guidelines.
- Always wear impervious gloves when spraying or cleaning equipment.

**PERSONAL PROTECTIVE EQUIPMENT**

You must wear appropriate protective equipment when operating, servicing, or when in the operating area of the equipment to help protect you from serious injury, including eye injury, inhalation of toxic fumes, burns, and hearing loss. This equipment includes but is not limited to:

- Protective eyewear
- Clothing and respirator as recommended by the fluid and solvent manufacturer
- Gloves
- Hearing protection

# Repair

## Grounding

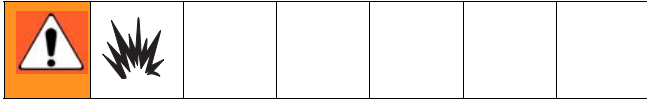

The equipment must be grounded. Grounding reduces the risk of static and electric shock by providing an escape wire for the electrical current due to static build up or in the event of a short circuit.

**Pump:** use a ground wire and clamp. Remove the green ground screw (Z) from the bottom of the air motor. Insert the screw through the loop on the end of the ground wire (Y) and reattach the screw to the air motor. Connect the ground clamp to a true earth ground. See FIG. 1.

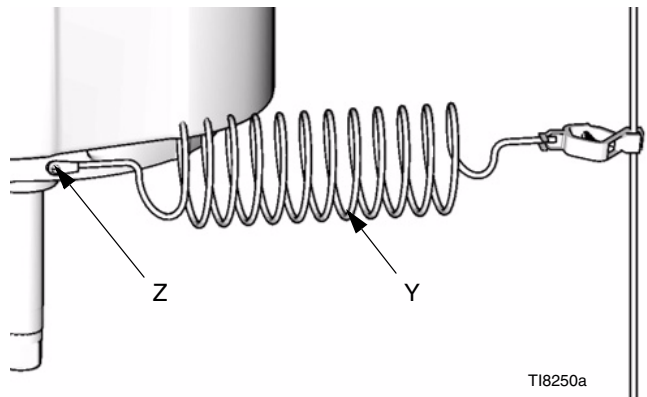

FIG. 1

**Air and fluid hoses:** use only electrically conductive hoses with a maximum of 500 ft. (150 m) combined hose length to ensure grounding continuity. Check the electrical resistance of hoses. If total resistance to ground exceeds 29 megohms, replace hose immediately.

**Air compressor:** follow manufacturer's recommendations.

**Hydraulic power supply:** follow manufacturer's recommendations.

**Surge tank:** use a ground wire and clamp.

**Spray gun:** ground through a connection to a properly grounded fluid hose and pump.

**Fluid supply container:** follow local code.

**Object being sprayed:** follow local code.

**Solvent pails used when flushing:** follow local code. Use only conductive metal pails, placed on a grounded surface. Do not place the pail on a nonconductive surface, such as paper or cardboard, which interrupts grounding continuity.

**To maintain grounding continuity when flushing or relieving pressure:** hold metal part of the spray gun firmly to the side of a grounded metal pail, then trigger the gun.

## Pressure Relief Procedure

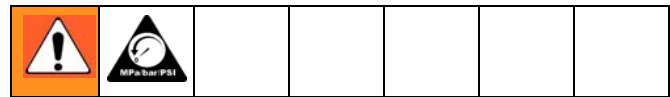

1. Engage trigger lock.
2. *Air-Powered Pumps only:* Close the bleed-type master air valve.

*Hydraulic-Powered Pumps only:* Close the hydraulic supply line valve first, then the return line valve.

3. Disengage the trigger lock.
4. Hold a metal part of the gun firmly to a grounded metal pail. Trigger the gun to relieve pressure.
5. Engage the trigger lock.
6. Open all fluid drain valves in the system, having a waste container ready to catch drainage. Leave drain valve(s) open until you are ready to spray again.
7. If you suspect the spray tip or hose is clogged or that pressure has not been fully relieved after following the steps above, VERY SLOWLY loosen tip guard retaining nut or hose end coupling to relieve

pressure gradually, then loosen completely. Clear hose or tip obstruction.

**CAUTION**

*Hydraulic-Powered Pumps only:* When shutting down the hydraulic system, always shut off the hydraulic supply line shutoff valve first, and then the return line shutoff valve to prevent overpressurizing the motor or its seals. When starting the hydraulic system, open the return line shutoff valve first.

**CAUTION**  
Be careful not to drop or damage the balls (13) or seats (17). A damaged ball or seat cannot seal properly and the pump will leak. The outlet valve seats (17) can be reversed to provide longer use of the seat.

## Dissassembly



- The following repair procedure can be used for any HIGH FLO model pump. The reference numbers used in the text and illustrations correspond to all of the displacement pump parts drawings.
- Packing repair kits are available for each pump. Parts included in the pump seal repair kit are marked with an asterisk in the text (for example, 16\*). Parts included in the throat packing kit are marked with a symbol (for example, 39†). Conversion kits are also available. See page 31. Use all the new parts in the kits for the best results.
- This pump is easiest to repair when left in the Part No. 218742 accessory pump stand and disassembled as instructed. For repair at a remote location, have another pump stand available.
- When reassembling, apply anti-seize lubricant 222955 on the threads of the piston shaft (29) and piston (23).

- Use a 13 mm socket wrench to loosen and remove the twelve capscrews (2) and lockwashers (3) on the outlet manifold (1). See FIG. 9.
- Lift the manifold (1) off the outlet valve housing (5) and remove the ball guides (14), balls (13), seats (17) and seals (15). Remove the o-ring (16) from the seats (17).



Seat Puller Kit 220384 is available to make removal of the seats from the manifolds easier. See FIG. 2.

### Seat Puller Kit 220384

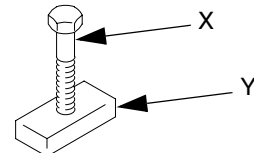

Screw bolt (X, Part 108481) into Seat Puller (Y, Part 181630).

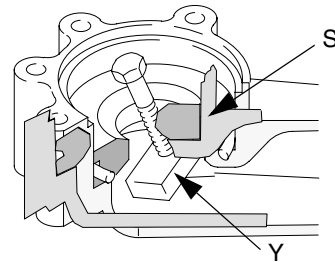

Position Seat Puller (Y) under the seat (Ref. 22 on pages 13, 14, 15) by slipping it through at an angle.

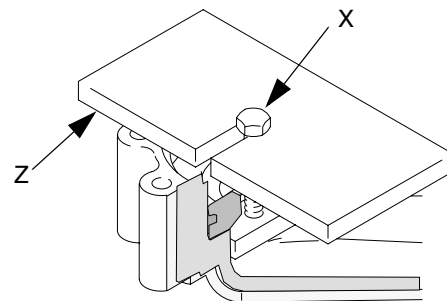

Place Seat Puller (Z, Part 181629) on top of seat. Turn bolt (X) to pull the seat out.

**FIG. 2**

01414

- Remove the nuts (8), lockwashers (7), and six cylinder capscrews (4). Loosen the wet cup (12). Lift off the outlet valve housing (5). See Manual 311831.
- Lift the riser tubes (20) and cylinder (27) off the inlet valve housing (6). The piston assembly may stay in

the cylinder. Remove the seals (21 and 28) from the inlet and outlet housings (5, 6). See FIG. 9.

 Tap on the valve housings with a plastic mallet and use a slight rocking motion to help loosen and remove the cylinder and tubes.

5. Screw out the wet cup (12). Using a small, flat-bladed screw driver pry out the cartridge gland (32) using the groove on the outer surface. Remove remaining packings (31,35) and glands (30, 42) from the nut. See FIG. 3.
6. Unscrew and remove the three pump stand bolts (D). See Manual 311831. Lift the inlet valve assembly off the stand. Place the inlet valve housing (6) face down on a protected surface.

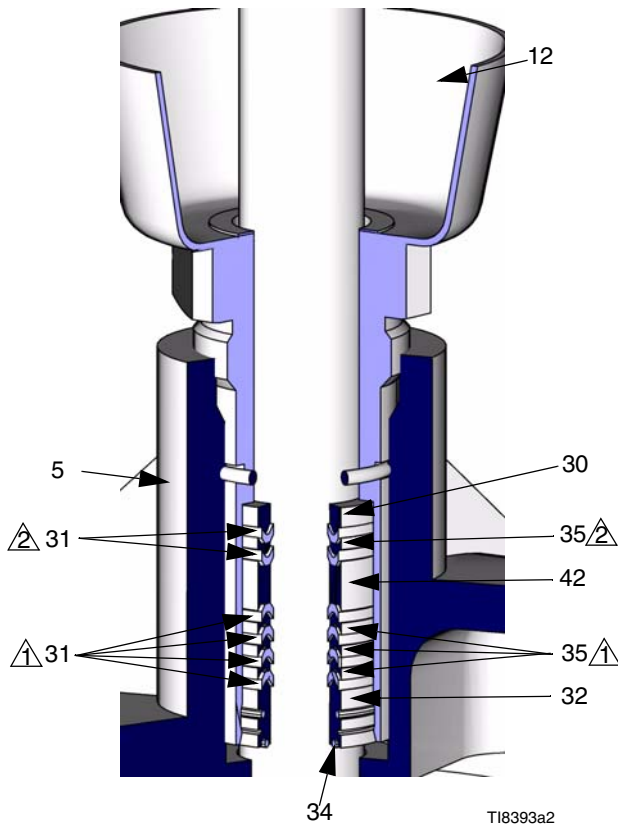

 Lips of v-packings face down.

 Lips of v-packings face up.

FIG. 3

7. Use a 13 mm socket wrench to loosen and remove the twelve capscrews (2) and lockwashers (3) from the inlet manifold (1). See FIG. 9.
8. Lift the manifold (1) off the inlet valve housing (6) and remove the seats (17 and 22). Remove the o-ring (16) from the seats.

**CAUTION**

If the pressure relief valve in the inlet seat (22) is clogged or filled with material, soak the inlet seat in a compatible solvent. Make sure all material residue is cleaned from the ball and seat area.

If the relief valve cannot be thoroughly cleaned so that the ball and spring are free to move, replace the seat (22).

9. Inspect the pressure relief valve in the fluid inlet seat (22) to make sure it is not clogged. Press down on the valve's ball to see if the ball and spring are free to move. See the detail in FIG. 9.

**CAUTION**

Be careful not to drop or damage the balls (13) or seats (17 or 22). A damaged ball or seat cannot seal properly and the pump will leak. One inlet valve seat (17) can be reversed to provide longer use of the seat. However, the fluid inlet seat (22) contains a pressure relief valve and is not reversible. See the detail in FIG. 9 for proper orientation.

10. Remove the balls (13), ball guides (14) and seals (15) from the inlet valve housing (6).
11. Push the piston assembly through the cylinder just enough to expose the piston (23) flats. Secure the piston flats in a vise. Use a plastic mallet to tap the cylinder (27) up and off the piston assembly.

 See FIG. 4 for steps 12-16.

12. Loosen the piston nut (26). Use Tool Kit 220385 to remove the piston shaft (29) and piston nut (26). See FIG. 5. Remove the piston nut o-ring (18) and o-ring retainer (43) from the shaft. Remove the plate (25) and the seal (24) from the piston (23). See FIG. 4.
13. Inspect the piston shaft (29). If it is damaged or the surface is scored, replace it.



14. Clean all piston parts and the cylinder thoroughly in a compatible solvent. Inspect the inner surface of the cylinder for scoring, and replace it if necessary. A scored cylinder will quickly damage the packings.

## Reassembly

15. Lubricate the new piston seal (24\*) and install it on the piston.
16. Install the piston plate (25) with the beveled edge facing away from the piston seal. See FIG. 4.

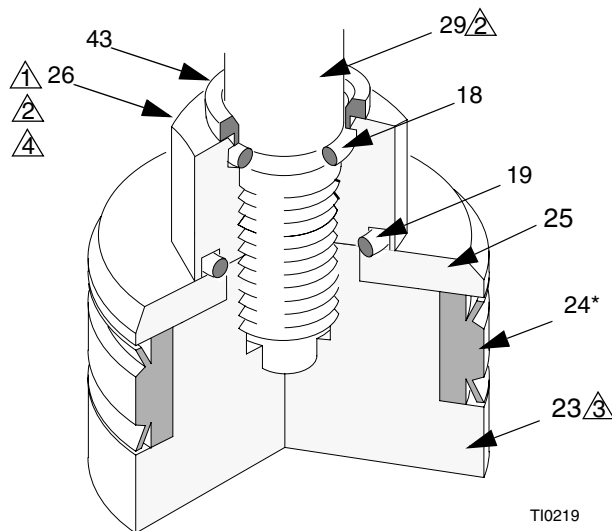

- ① Torque to 270-284 N•m (200-210 ft-lb).
- ② Apply medium strength thread locker to threads.
- ③ Lubricate.
- ④ Apply anti-seize lubricant 222955 to the face of piston nut.

FIG. 4

## Tool Kit 220385

Tighten the tool on the widest part of the shaft (29). Grip the tool with a wrench and unscrew the shaft.

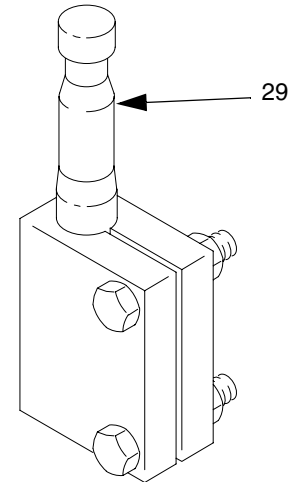

01413

FIG. 5

17. Install o-ring retainer (43). Lubricate o-ring (18) and slide it on over the threads of piston shaft. Apply medium strength liquid thread adhesive to the piston nut (26) threads and the piston rod. Screw the nut snugly against the o-ring retainer (43). Apply anti-seize lubricant 222955 to the bottom face of the piston nut (26). Assemble o-ring (19) and install in the groove on the piston nut. Screw rod (29) into piston (23) until snug. Tighten piston nut (26) to 270-284 N•m. (200-210 ft-lb).
18. Remove the piston assembly from the vise, but **do not lay it down on its side; doing so may damage the seal.**



See FIG. 6 for step 19.

19. Carefully and evenly guide the seal and the piston into the cylinder. The piston seal and piston may need to be tipped at an angle and the exposed, leading lip of the seal tapped into the cylinder with a plastic mallet. After the seal lip has entered the cylinder use an arbor press or tap the bottom of the piston assembly lightly with a plastic mallet to slide the piston assembly into the cylinder. Before pressing, ensure the piston seal lips are started into the cylinder. See FIG. 6.
20. Clean the remaining pump parts in a compatible solvent.

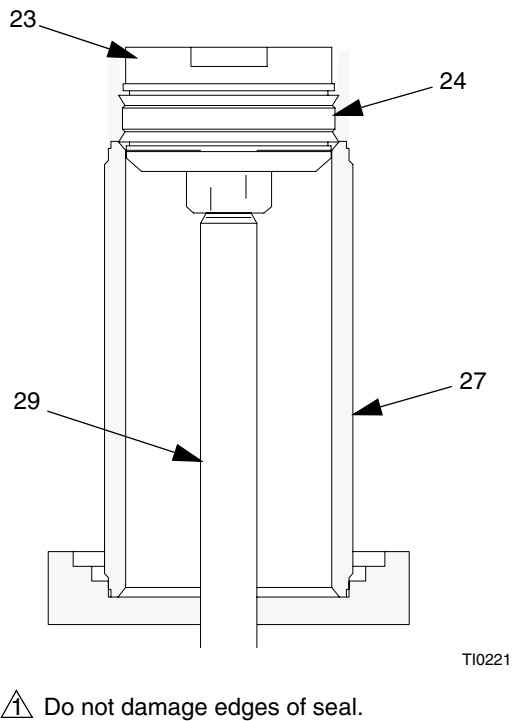

**FIG. 6**

 See FIG. 7 for steps 21 and 22.

21. Lubricate three new throat packings (two - 31†) and (one - 35†) and the male gland (30†) with light grease. Holding the wet cup (12), drop the gland (30†) into the wet cup so that the lips face up. Alternately set the three v-packings with the lips facing up into the wet cup one at a time, starting with 31†, followed by 35†, and ending with 31†. See FIG. 7.
22. Lubricate the female gland (42†) well and place it in the wet cup. Lubricate seven new throat packings (four - 31†) and (three - 35†) with light grease. Alternately set the seven v-packings with the lips facing down into the wet cup one at a time, starting with (31†), followed by (35†), and ending with (31†). Lightly grease gland assembly (32) and press fit into wetcup (12) until you feel the o-ring (A) snap into groove. Place lubricated o-ring (34) into groove on the face of the gland assembly (32). See FIG. 7.

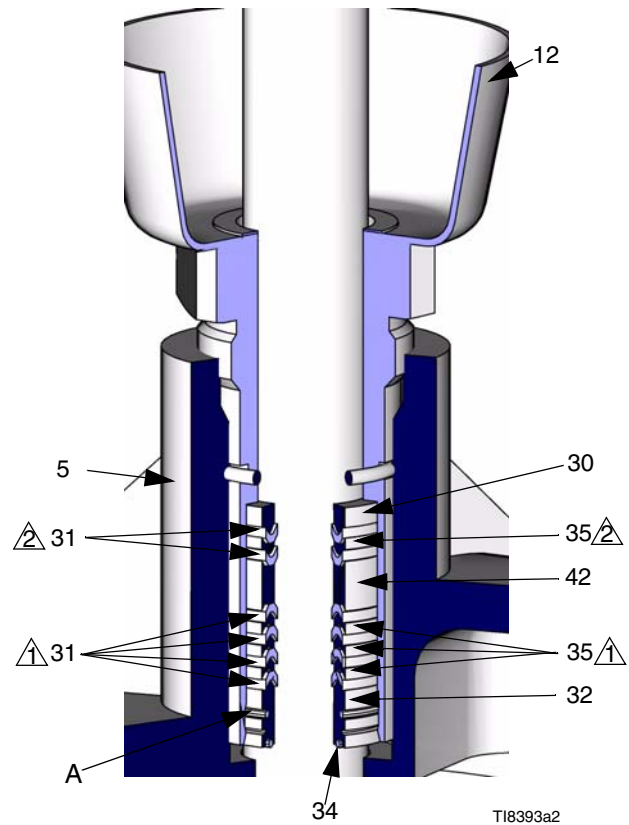

 Lips of v-packings face down.

 Lips of v-packings face up.

**FIG. 7**

 See FIG. 9 for steps 23-25 unless otherwise indicated.

23. Loosely screw the wet cup (12) into the outlet valve housing (5). See FIG. 9.
24. Lubricate and install the new o-rings (16\*) around each of the four ball seats (17 and 22).

**CAUTION**

The orientation of the ball valves in the inlet and outlet valve housings is critical. Install the parts of the ball valve exactly as instructed and refer to FIG. 9. If installed incorrectly, the pump will not operate.

25. Place the inlet valve housing (6) on a flat surface with the ball valve openings facing up. Lubricate the seals (15\*) and set them into each side of the inlet valve housing.

26. Place the ball guides (14) and balls (13) in the inlet valve housing.
27. Press the seat (22) with the pressure relief valve into the fluid inlet side of the inlet manifold (1). This seat is not reversible. Orient as shown in the detail in FIG. 9. Press the other seat (17), with the unworn side facing out, into the other side of the inlet manifold.

 The pressure relief seat kit (22) includes two seals (15) and two o-rings (16). When installing a new pressure relief seat, also install the seals and o-rings on both sides of the fluid inlet manifold (1).

28. Position the inlet manifold (1) on the inlet valve housing (6). Install the twelve capscrews (2) and lockwashers (3) loosely.
29. Tighten the four inside capscrews oppositely and evenly to 3 N•m (27 in-lb) to balance the load on the valves. Then tighten all twelve capscrews oppositely and evenly to 11.5-24.5 N•m (8.5-18 ft-lb). See FIG. 8.
30. Place the inlet valve housing and manifold assembly on the pump stand. Install and tightly screw in the three pump stand bolts (D). See Manual 311831.
31. Lubricate and install the new seals (21\*, 28\*) in the inlet and outlet housings (6, 5). Set the cylinder (27) and riser tubes (20) into place in the inlet valve housing (6). Set the outlet housing (5) onto the cylinder and riser tubes.
32. Install the six cylinder capscrews (4), lockwashers (18) and nuts (19). Tighten the capscrews oppositely and evenly to 81-88 N•m (60-65 ft-lb). See FIG. 8.
33. Lubricate the seals (15\*) and press one into each side of the outlet valve housing (5). Press the seats (17), with the unworn sides facing the balls, into the outlet valve housing. Then install the balls (13) and ball guides (14).
34. Place the outlet manifold (1) on the outlet valve housing (5) and install the twelve capscrews (2) and lockwashers (3) loosely. Tighten the inside four capscrews oppositely and evenly to 3 N•m (27 in-lb) to balance the load on the valves. Then tighten all twelve capscrews oppositely and evenly to 24-27 N•m (18-20 ft-lb). See FIG. 8.

35. Torque the wet cup (12) to 67 N•m (50 ft-lb). Back off and re-torque to 27-34 N•m (20-25 ft-lb).
36. Reconnect the motor. Be sure the grounding wire is connected.

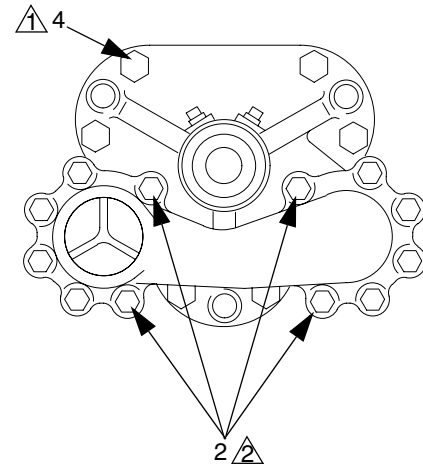

01410

 4 Torque oppositely and evenly to 81-88 N•m (60-65 ft-lb).

 2 Torque these 4 screws oppositely and evenly to 3 N•m (27 in-lb), then tighten all 12 screws oppositely and evenly to 24-27 N•m (18-20 ft-lb).

**FIG. 8**

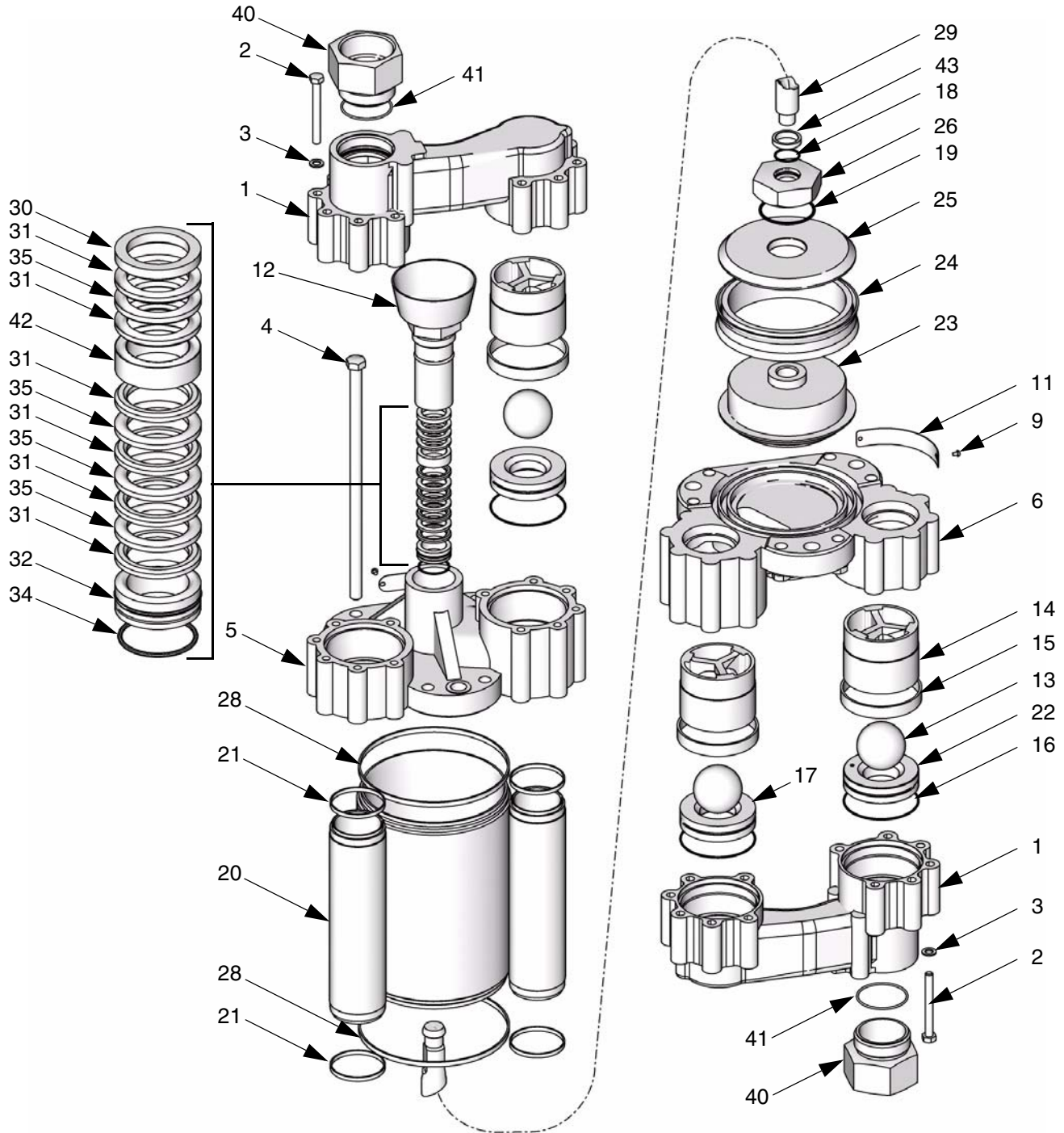

T18338a

- ① Apply lubricant to all packings.
- ② Apply thread sealant.
- ③ Torque to 70-75 ft-lbs (95-102 N•m).

FIG. 9

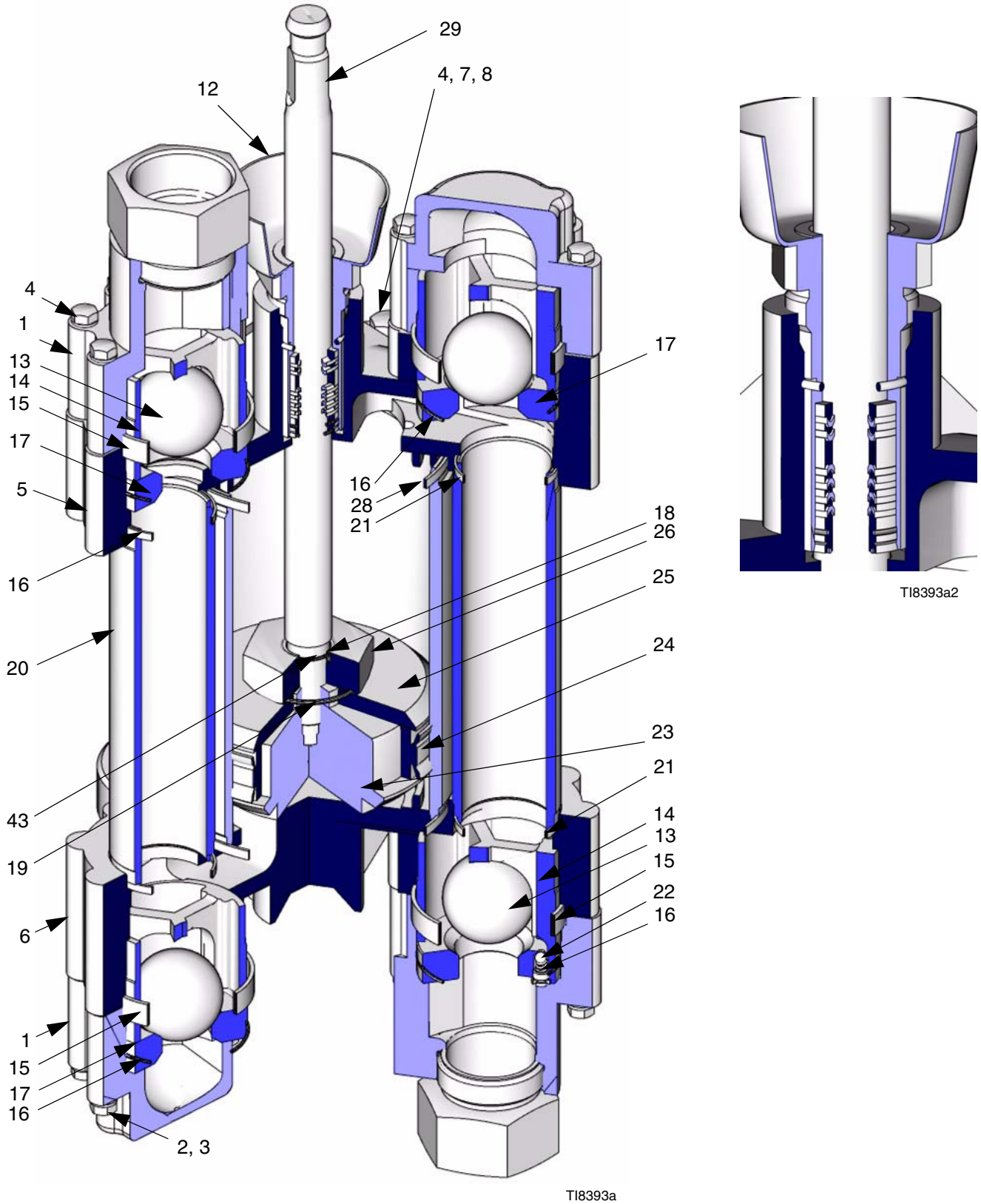

FIG. 10

# Lower Parts

2000cc Lower parts list, see page 15

3000cc Lower parts list, see page 16

4000cc Lower parts list, see page 17

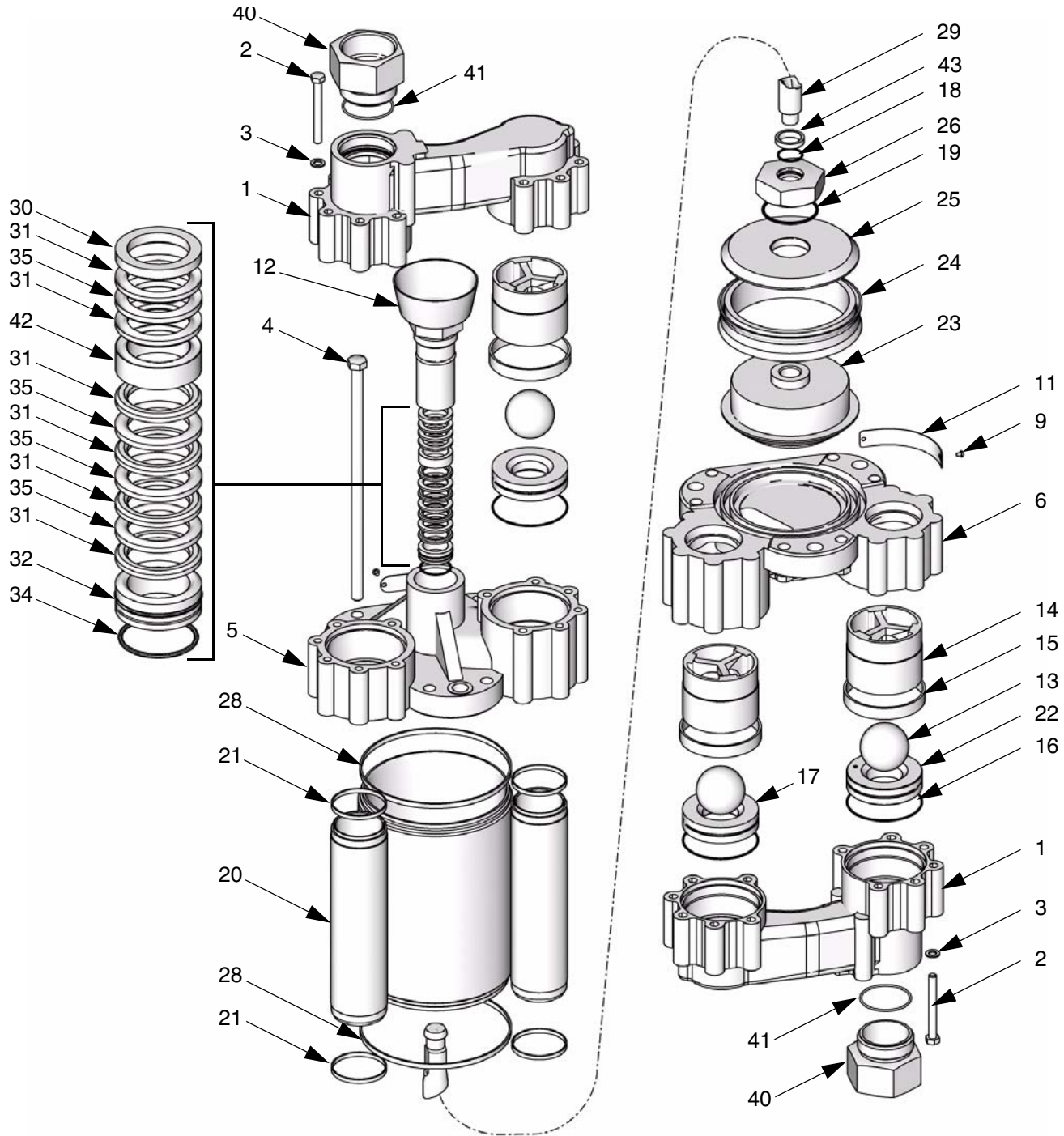

- ① Apply lubricant to all packings.
- ② Apply thread sealant.
- ③ Torque to 70-75 ft-lbs (95-102 N•m).

TI8338a



## 2000cc Lowers

Part No. 243731, Series D, Carbon Steel

Part No. 243734, Series D, Stainless Steel

Part No. 243771, Series D, Stainless Steel

Part No. 248329, Series B, Stainless Steel

Part No. 248332, Series B, Stainless Steel

Ref.	Description	Lower					Qty
		243731	243734	243771	248329	248332	
1	MANIFOLD	180520					2
	MANIFOLD		193203	193203	193203	193203	2
2	CAPSCREW, hex hd; M8 x 1.25; sst	107554	107554	107554	107554	107554	24
3	WASHER, flat; 8.4 mm; sst	111003	111003	111003	111003	111003	24
4	CAPSCREW, hex hd; M12 x 1.25; sst	107553	107553	107553	107553	107553	6
5	HOUSING, outlet; cst	180522					1
	HOUSING, outlet; sst		180524	180524	180524	180524	1
6	HOUSING, inlet; cst	180521					1
	HOUSING, inlet; sst		180523	180523	180523	180523	1
7	WASHER, lock	108792	108792	108792	108792	108792	6
8	NUT, M8 x 1.25; sst	107538	107538	107538	107538	107538	6
9	SCREW, drive	103972	103972	103972	103972	103972	4
12	CUP, wet, ass'y	254966	254966	254966	254966	254966	1
13	BALL, intake; 2 in. (51 mm) dia.; sst	110294	110294	110294	110294	110294	4
14	GUIDE, ball; sst	180509	180509	180509	180509	180509	4
15	SEAL, UHMWPE	180761	180761	180761	180761	180761	4
16	PACKING, o-ring; PTFE	107545	107545	107545	107545	107545	4
17	SEAT, valve, sst	180529	180529	180529	180529	180529	3
18	PACKING, o-ring; PTFE encapsulated fluoroelastomer	115929	115929	115929	115929	115929	1
19	PACKING, o-ring; PTFE	115930	115930	115930	115930	115930	1
20	TUBE, riser	180530	180530	180530	180530	180530	2
21	SEAL, UHMWPE	180760	180760	180760	180760	180760	4
22	SEAT, valve; relief	237572	237572	237572	237572	237572	1
23	PISTON, pump	196261	196261	196261	196261	196261	1
24	SEAL, piston; UHMWPE	196232	196232	196232	196232	196232	1
25	PLATE, retaining	196262	196262	196262	196262	196262	1
26	NUT, jam	196243	196243	196243	196243	196243	1
27	CYLINDER, pump	180499	180499	180499	180499	180499	1
28	SEAL, UHMWPE	180759	180759	180759	180759	180759	2
29	SHAFT, piston	196228	196228	196228			1
	SHAFT, piston				185197	185197	1
30	GLAND, packing, male	198360	198360	198360	198360	198360	1
31	V-PACKING, UHMWPE	180641	180641	180641	180641	180641	6
32	GLAND, cartridge	243839	243839	243839	243839	243839	1
33▲	TAG, warning	196685	196685	196685	196685	196685	1
34	O-RING, PTFE	109213	109213	109213	109213	109213	1
35	V-PACKING, leather	15J057	15J057	15J057	15J057	15J057	4
40	FITTING, 2 in. npt, 2 in. bspp			196321		196321	2
41	SEAL, PTFE			193424		193424	2
42	GLAND, packing, female	196216	196216	196216	196216	196216	1
43	RETAINER, o-ring piston	196356	196356	196356	196356	196356	1

▲ Replacement Danger and Warning labels, tags, and cards are available at no cost.

\* Parts included in Seal Repair Kit (purchase separately). See page 18.

† Parts included in Throat Packing Repair Kit (purchase separately). See page 18.

**3000cc Lowers****Part No. 243732, Series D, Carbon Steel****Part No. 243735, Series D, Stainless Steel****Part No. 243772, Series D, Stainless Steel****Part No. 248330, Series B, Stainless Steel****Part No. 248333, Series B, Stainless Steel**

Ref.	Description	Lower					Qty
		243732	243735	243772	248330	248333	
1	MANIFOLD	180520					2
	MANIFOLD		193203	193203	193203	193203	2
2	CAPSCREW, hex hd; M8 x 1.25; sst	107554	107554	107554	107554	107554	24
3	WASHER, flat; 8.4 mm; sst	111003	111003	111003	111003	111003	24
4	CAPSCREW, hex hd; M12 x 1.25; sst	107553	107553	107553	107553	107553	6
5	HOUSING, outlet; cst	180522					1
	HOUSING, outlet; sst		180524	180524	180524	180524	1
6	HOUSING, inlet; cst	180521					1
	HOUSING, inlet; sst		180523	180523	180523	180523	1
7	WASHER, lock	108792	108792	108792	108792	108792	6
8	NUT, M8 x 1.25; sst	107538	107538	107538	107538	107538	6
9	SCREW, drive	103972	103972	103972	103972	103972	4
12	CUP, wet, ass'y	254966	254966	254966	254966	254966	1
13	BALL, intake; 2 in. (51 mm) dia.; sst	110294	110294	110294	110294	110294	4
14	GUIDE, ball; sst	180509	180509	180509	180509	180509	4
15	SEAL, UHMWPE	180761	180761	180761	180761	180761	4
16	PACKING, o-ring; PTFE	107545	107545	107545	107545	107545	4
17	SEAT, valve, sst	180529	180529	180529	180529	180529	3
18	PACKING, o-ring; PTFE encapsulated fluoroelastomer	115929	115929	115929	115929	115929	1
19	PACKING, o-ring; PTFE	115930	115930	115930	115930	115930	1
20	TUBE, riser	180530	180530	180530	180530	180530	2
21	SEAL, UHMWPE	180760	180760	180760	180760	180760	4
22	SEAT, valve; relief	237572	237572	237572	237572	237572	1
23	PISTON, pump	196263	196263	196263	196263	196263	1
24	SEAL, piston; UHMWPE	196233	196233	196233	196233	196233	1
25	PLATE, retaining	196264	196264	196264	196264	196264	1
26	NUT, jam	196243	196243	196243	196243	196243	1
27	CYLINDER, pump	180498	180498	180498	180498	180498	1
28	SEAL, UHMWPE	180758	180758	180758	180758	180758	2
29	SHAFT, piston	196228	196228	196228			1
	SHAFT, piston				185197	185197	1
30	GLAND, packing, male	198360	198360	198360	198360	198360	1
31	V-PACKING, UHMWPE	180641	180641	180641	180641	180641	6
32	GLAND, cartridge	243839	243839	243839	243839	243839	1
33▲	TAG, warning	196685	196685	196685	196685	196685	1
34	O-RING, PTFE	109213	109213	109213	109213	109213	1
35	V-PACKING, leather	15J057	15J057	15J057	15J057	15J057	4
40	FITTING, 2 in. npt, 2 in. bspp			196321	196321	196321	2
41	SEAL, PTFE			193424	193424	193424	2
42	GLAND, packing, female	196216	196216	196216	196216	196216	1

▲ Replacement Danger and Warning labels, tags, and cards are available at no cost.

\* Parts included in Seal Repair Kit (purchase separately). See page 18.

† Parts included in Throat Packing Repair Kit (purchase separately). See page 18.



## 4000cc Lowers

Part No. 243733, Series D, Carbon Steel

Part No. 243736, Series D, Stainless Steel

Part No. 243773, Series D, Stainless Steel

Part No. 248331, Series B, Stainless Steel

Part No. 248334, Series B, Stainless Steel

Ref.	Description	Lower					Qty
		243733	243736	243773	248331	248334	
1	MANIFOLD	180520					2
	MANIFOLD		193203	193203	193203	193203	2
2	CAPSCREW, hex hd; M8 x 1.25; sst	107554	107554	107554	107554	107554	24
3	WASHER, flat; 8.4 mm; sst	111003	111003	111003	111003	111003	24
4	CAPSCREW, hex hd; M12 x 1.25; sst	107553	107553	107553	107553	107553	6
5	HOUSING, outlet; cst	180522					1
	HOUSING, outlet; sst		180524	180524	180524	180524	1
6	HOUSING, inlet; cst	180521					1
	HOUSING, inlet; sst		180523	180523	180523	180523	1
7	WASHER, lock	108792	108792	108792	108792	108792	6
8	NUT, M8 x 1.25; sst	107538	107538	107538	107538	107538	6
9	SCREW, drive	103972	103972	103972	103972	103972	4
12	CUP, wet, ass'y	254966	254966	254966	254966	254966	1
13	BALL, intake; 2 in. (51 mm) dia.; sst	110294	110294	110294	110294	110294	4
14	GUIDE, ball; sst	180509	180509	180509	180509	180509	4
15	SEAL, UHMWPE	180761	180761	180761	180761	180761	4
16	PACKING, o-ring; PTFE	107545	107545	107545	107545	107545	4
17	SEAT, valve, sst	180529	180529	180529	180529	180529	3
18	PACKING, o-ring; PTFE encapsulated fluoroelastomer	115929	115929	115929	115929	115929	1
19	PACKING, o-ring; PTFE	115930	115930	115930	115930	115930	1
20	TUBE, riser	180530	180530	180530	180530	180530	2
21	SEAL, UHMWPE	180760	180760	180760	180760	180760	4
22	SEAT, valve; relief	237572	237572	237572	237572	237572	1
23	PISTON, pump	196265	196265	196265	196265	196265	1
24	SEAL, piston; UHMWPE	196234	196234	196234	196234	196234	1
25	PLATE, retaining	196266	196266	196266	196266	196266	1
26	NUT, jam	196243	196243	196243	196243	196243	1
27	CYLINDER, pump	180497	180497	180497	180497	180497	1
28	SEAL, UHMWPE	180757	180757	180757	180757	180757	2
29	SHAFT, piston	196228	196228	196228			1
	SHAFT, piston				185197	185197	1
30	GLAND, packing, male	198360	198360	198360	198360	198360	1
31	V-PACKING, UHMWPE	180641	180641	180641	180641	180641	6
32	GLAND, cartridge	243839	243839	243839	243839	243839	1
33▲	TAG, warning	196685	196685	196685	196685	196685	1
34	O-RING, PTFE	109213	109213	109213	109213	109213	1
35	V-PACKING, leather	15J057	15J057	15J057	15J057	15J057	4
40	FITTING, 2 in. npt, 2 in. bspp			196321	196321	196321	2
41	SEAL, PTFE			193424	193424	193424	2
42	GLAND, packing, female	196216	196216	196216	196216	196216	1

▲ Replacement Danger and Warning labels, tags, and cards are available at no cost.

\* Parts included in Seal Repair Kit (purchase separately). See page 18.

† Parts included in Throat Packing Repair Kit (purchase separately). See page 18.



A series of 20 horizontal lines spaced evenly down the page, providing a template for handwriting practice. The lines are parallel and extend across most of the width of the page.

# Repair and Conversion Kits

Use Only Genuine Graco Parts and Accessories

## Piston Seal Repair Kit 243727

For Displacement Pumps 243731 & 243734.

Ref.	Part No.	Description	Qty
15	180761	SEAL; UHMWPE	4
16	107545	O-RING; PTFE	4
18	115929	PACKING, O-RING	1
19	115930	PACKING, O-RING	1
21	180760	SEAL; UHMWPE	4
24	196232	SEAL, piston; UHMWPE	1
28	180759	SEAL; UHMWPE	2

## Piston Seal Repair Kit 243728

For Displacement Pump 243732 & 243735.

Ref.	Part No.	Description	Qty
15	180761	SEAL; UHMWPE	4
16	107545	O-RING; PTFE	4
18	115929	PACKING, O-RING	1
19	115930	PACKING, O-RING	1
21	180760	SEAL; UHMWPE	4
24	196233	SEAL, piston; UHMWPE	1
28	180758	SEAL; UHMWPE	2

## Piston Seal Repair Kit 243729

For Displacement Pumps 243733 & 243736.

Ref.	Part No.	Description	Qty
15	180761	SEAL; UHMWPE	4
16	107545	O-RING; PTFE 4	4
18	115929	PACKING, O-RING	1
19	115930	PACKING, O-RING	1
21	180760	SEAL; UHMWPE	4
24	196234	SEAL, piston; UHMWPE	1
28	180757	SEAL; UHMWPE	2

## UHMWPE/Leather Throat Packing Repair Kit 243671.

For all pumps.

Ref.	Part No.	Description	Qty
30	198360	GLAND, packing, male	1
31	180641	V-PACKING, UHMWPE	6
32	243839	GLAND, packing male	1
34	109213	O-RING, PTFE	1
35	15J057	V-PACKING, leather	4
42	196216	GLAND, packing female	1

## Coupling Jaw Kit 15D950.

For all chrome SST pumps.

Ref.	Part No.	Description	Qty
	184129	COLLAR, coupling	2
	186925	NUT, coupling	1
29	196228	SHAFT, piston, chrome	1

## PTFE/Leather Throat Packing Repair Kit 243672.

For all pumps.

Ref.	Part No.	Description	Qty
30	198360	GLAND, packing, male	1
31	190298	V-PACKING, PTFE	6
32	243839	GLAND, packing, male	1
34	109213	O-RING, PTFE	1
35	15J057	V-PACKING, leather	4
42	196216	GLAND, packing, female	1

## Triple Lip\_ Throat Conversion Kit 243673.

For all pumps.

Part No.	Description	Qty
115906	O-RING	1
196240	BEARING	1
243674	SEAL, Throat	1

## Piston Seal Conversion Kit 235855

For Displacement Pump 243732 & 243735.

Ref.	Part No.	Description	Qty
15	180761	SEAL; UHMWPE	4
16	107545	O-RING; PTFE	4
18	115929	PACKING, O-RING	1
19	115930	PACKING, O-RING	1
21	180760	SEAL; UHMWPE	4
24	112037	SEAL; unfilled PTFE	1
28	180758	SEAL; UHMWPE	2

## Piston Seal Conversion Kit 235856

For Displacement Pumps 243731 & 243734.

Ref.	Part No.	Description	Qty
15	180761	SEAL; UHMWPE	4
16	107545	O-RING; PTFE	4
18	115929	PACKING, O-RING	1
19	115930	PACKING, O-RING	1
21	180760	SEAL; UHMWPE	4
24	112038	SEAL; unfilled PTFE	1
28	180759	SEAL; UHMWPE	2

## Piston Seal Conversion Kit 235854

For Displacement Pumps 243733 & 243736.

Ref.	Part No.	Description	Qty
15	180761	SEAL; UHMWPE	4
16	107545	O-RING; PTFE	4
18	115929	PACKING, O-RING	1
19	115930	PACKING, O-RING	1
21	180760	SEAL; UHMWPE	4
24	112036	SEAL; unfilled PTFE	1
28	180757	SEAL; UHMWPE	2

## Coupling Jaw Kit 243948

For CST and Electropolished SST pumps.

Ref.	No.	Part No.	Description	Qty
		184129	COLLAR, coupling	2
		186925	NUT, coupling	1
29		196228	SHAFT, piston (Tuff Coat_)	1

# Graco Standard Warranty

Graco warrants all equipment referenced in this document which is manufactured by Graco and bearing its name to be free from defects in material and workmanship on the date of sale to the original purchaser for use. With the exception of any special, extended, or limited warranty published by Graco, Graco will, for a period of twelve months from the date of sale, repair or replace any part of the equipment determined by Graco to be defective. This warranty applies only when the equipment is installed, operated and maintained in accordance with Graco's written recommendations.

This warranty does not cover, and Graco shall not be liable for general wear and tear, or any malfunction, damage or wear caused by faulty installation, misapplication, abrasion, corrosion, inadequate or improper maintenance, negligence, accident, tampering, or substitution of non-Graco component parts. Nor shall Graco be liable for malfunction, damage or wear caused by the incompatibility of Graco equipment with structures, accessories, equipment or materials not supplied by Graco, or the improper design, manufacture, installation, operation or maintenance of structures, accessories, equipment or materials not supplied by Graco.

This warranty is conditioned upon the prepaid return of the equipment claimed to be defective to an authorized Graco distributor for verification of the claimed defect. If the claimed defect is verified, Graco will repair or replace free of charge any defective parts. The equipment will be returned to the original purchaser transportation prepaid. If inspection of the equipment does not disclose any defect in material or workmanship, repairs will be made at a reasonable charge, which charges may include the costs of parts, labor, and transportation.

**THIS WARRANTY IS EXCLUSIVE, AND IS IN LIEU OF ANY OTHER WARRANTIES, EXPRESS OR IMPLIED, INCLUDING BUT NOT LIMITED TO WARRANTY OF MERCHANTABILITY OR WARRANTY OF FITNESS FOR A PARTICULAR PURPOSE.**

Graco's sole obligation and buyer's sole remedy for any breach of warranty shall be as set forth above. The buyer agrees that no other remedy (including, but not limited to, incidental or consequential damages for lost profits, lost sales, injury to person or property, or any other incidental or consequential loss) shall be available. Any action for breach of warranty must be brought within two (2) years of the date of sale.

**GRACO MAKES NO WARRANTY, AND DISCLAIMS ALL IMPLIED WARRANTIES OF MERCHANTABILITY AND FITNESS FOR A PARTICULAR PURPOSE, IN CONNECTION WITH ACCESSORIES, EQUIPMENT, MATERIALS OR COMPONENTS SOLD BUT NOT MANUFACTURED BY GRACO.** These items sold, but not manufactured by Graco (such as electric motors, switches, hose, etc.), are subject to the warranty, if any, of their manufacturer. Graco will provide purchaser with reasonable assistance in making any claim for breach of these warranties.

In no event will Graco be liable for indirect, incidental, special or consequential damages resulting from Graco supplying equipment hereunder, or the furnishing, performance, or use of any products or other goods sold hereto, whether due to a breach of contract, breach of warranty, the negligence of Graco, or otherwise.

## **FOR GRACO CANADA CUSTOMERS**

The Parties acknowledge that they have required that the present document, as well as all documents, notices and legal proceedings entered into, given or instituted pursuant hereto or relating directly or indirectly hereto, be drawn up in English. Les parties reconnaissent avoir convenu que la rédaction du présente document sera en Anglais, ainsi que tous documents, avis et procédures judiciaires exécutés, donnés ou intentés, à la suite de ou en rapport, directement ou indirectement, avec les procédures concernées.

# Graco Information

**TO PLACE AN ORDER**, contact your Graco distributor or call to identify the nearest distributor.

**Phone:** 612-623-6921 **or Toll Free:** 1-800-328-0211 **Fax:** 612-378-3505

*All written and visual data contained in this document reflects the latest product information available at the time of publication.  
Graco reserves the right to make changes at any time without notice.*

This manual contains English. MM 311832

**Graco Headquarters:** Minneapolis

**International Offices:** Belgium, China, Japan, Korea

**GRACO INC. P.O. BOX 1441 MINNEAPOLIS, MN 55440-1441**

[www.graco.com](http://www.graco.com)

11/2006 Rev. 11/2006