

FinishPro™ 390/395 Airless/Air-Assisted Sprayer

311911 rev. A

- For the application of architectural paints and coatings -

Maximum Fluid Working Pressure: 3300 psi (227 bar, 22.7 MPa)

Maximum Air Working Pressure: 35 psi (2.4 bar, 0.24 MPa)



IMPORTANT SAFETY INSTRUCTIONS!

Read all warnings and instructions. Save these instructions. Contact Graco Customer Service, your local Graco distributor or our website: www.graco.com, to obtain a manual in your language.

Models:

Region	FinishPro 390	FinishPro 395
US	249690	249691
Europe CEE 7/7	255110	255111
Europe Multi Cord	255112	255113
UK	255114	255115
Asia/Australia	255116	255117

Related Manuals:



[311905](#)



[309250](#)



[311937](#)



[312100](#)

FinishPro 395

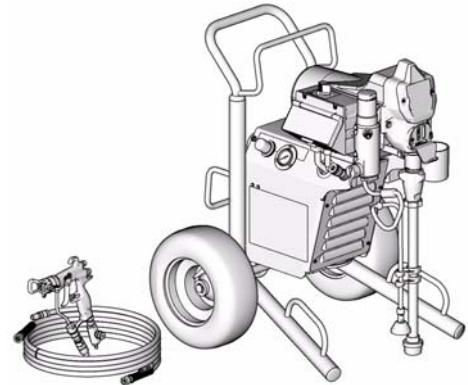

ti9026a

FinishPro 390

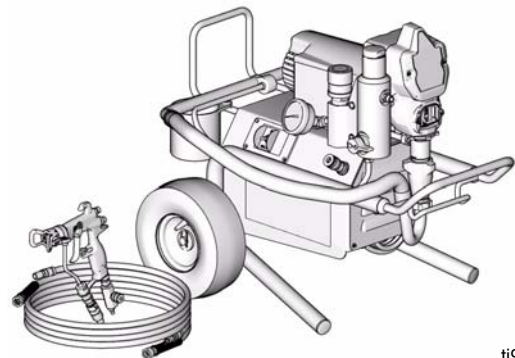









ti9019a

PROVEN QUALITY. LEADING TECHNOLOGY.

Warning

The following warnings are for the setup, use, grounding, maintenance and repair of this equipment. The exclamation point symbol alerts you to a general warning and the hazard symbol refers to procedure-specific risks. Refer back to these warnings. Additional, product-specific warnings may be found throughout the body of this manual where applicable.

 WARNING	
	<p>FIRE AND EXPLOSION HAZARD</p> <p>Flammable fumes, such as solvent and paint fumes, in work area can ignite or explode. To help prevent fire and explosion:</p> <ul style="list-style-type: none"> • Use equipment only in well ventilated area. • Eliminate all ignition sources; such as pilot lights, cigarettes, portable electric lamps, and plastic drop cloths (potential static arc). • Sprayer generates sparks. When flammable liquid is used in or near the sprayer or for flushing or cleaning, keep sprayer at least 20 feet (6 m) away from explosive vapors. • Keep work area free of debris, including solvent, rags and gasoline. • Do not plug or unplug power cords or turn lights on or off when flammable fumes are present. • Ground equipment and conductive objects in work area. Read Grounding instructions. • If there is static sparking or you feel a shock, stop operation immediately. Do not use equipment until you identify and correct the problem. • Keep a working fire extinguisher in the work area.
	<p>ELECTRIC SHOCK HAZARD</p> <p>Improper grounding, setup, or usage of the system can cause electric shock.</p> <ul style="list-style-type: none"> • Turn off and disconnect power cord before servicing equipment. • Use only grounded electrical outlets. • Use only 3-wire extension cords. • Ensure ground prongs are intact on sprayer and extension cords. • Do not expose to rain. Store indoors.
	<p>SKIN INJECTION HAZARD</p> <p>High-pressure fluid from gun, hose leaks, or ruptured components will pierce skin. This may look like just a cut, but it is a serious injury that can result in amputation. Get immediate surgical treatment.</p> <ul style="list-style-type: none"> • Do not point gun at anyone or at any part of the body. • Do not put your hand over the spray tip. • Do not stop or deflect leaks with your hand, body, glove, or rag. • Engage trigger lock when not spraying. • Follow Pressure Relief Procedure in this manual, when you stop spraying and before cleaning, checking, or servicing equipment.

	WARNING
	<p>EQUIPMENT MISUSE HAZARD</p> <p>Misuse can cause death or serious injury.</p> <ul style="list-style-type: none"> • Do not exceed the maximum working pressure or temperature rating of the lowest rated system component. Read Technical Data in all equipment manuals. • Use fluids and solvents that are compatible with equipment wetted parts. Read Technical Data in all equipment manuals. Read fluid and solvent manufacturer's warnings. For complete information about your material, request MSDS from distributor or retailer. • Check equipment daily. Repair or replace worn or damaged parts immediately with genuine Graco replacement parts only. • Do not alter or modify equipment. • Use equipment only for its intended purpose. Call your Graco distributor for information. • Route hoses and cables away from traffic areas, sharp edges, moving parts, and hot surfaces. • Do not kink or overbend hoses or use hoses to pull equipment. • Keep children and animals away from work area. • Comply with all applicable safety regulations. • Keep children and animals away from work area. • Do not operate the unity when fatigued or under the influence of drugs or alcohol.
	<p>PRESSURIZED ALUMINUM PARTS HAZARD</p> <p>Do not use 1,1,1-trichloroethane, methylene chloride, other halogenated hydrocarbon solvents or fluids containing such solvents in pressurized aluminum equipment. Such use can cause serious chemical reaction and equipment rupture, and result in death, serious injury, and property damage.</p>
	<p>BURN HAZARD</p> <p>Equipment surfaces can become very hot during operation. To avoid severe burns, do not touch hot equipment. Wait until equipment has cooled completely.</p>
	<p>MOVING PARTS HAZARD</p> <p>Moving parts can pinch or amputate fingers and other body parts.</p> <ul style="list-style-type: none"> • Keep clear of moving parts. • Do not operate equipment with protective guards or covers removed. • Pressurized equipment can start without warning. Before checking, moving, or servicing equipment, follow the Pressure Relief Procedure in this manual. Disconnect power or air supply.
	<p>TOXIC FLUID OR FUMES HAZARD</p> <p>Toxic fluids or fumes can cause serious injury or death if splashed in the eyes or on skin, inhaled, or swallowed.</p> <ul style="list-style-type: none"> • Read MSDS's to know the specific hazards of the fluids you are using. • Store hazardous fluid in approved containers, and dispose of it according to applicable guidelines.
	<p>PERSONAL PROTECTIVE EQUIPMENT</p> <p>You must wear appropriate protective equipment when operating, servicing, or when in the operating area of the equipment to help protect you from serious injury, including eye injury, inhalation of toxic fumes, burns, and hearing loss. This equipment includes but is not limited to:</p> <ul style="list-style-type: none"> • Protective eye wear • Clothing and respirator as recommended by the fluid and solvent manufacturer • Gloves • Hearing protection

Component Identification

FinishPro 390

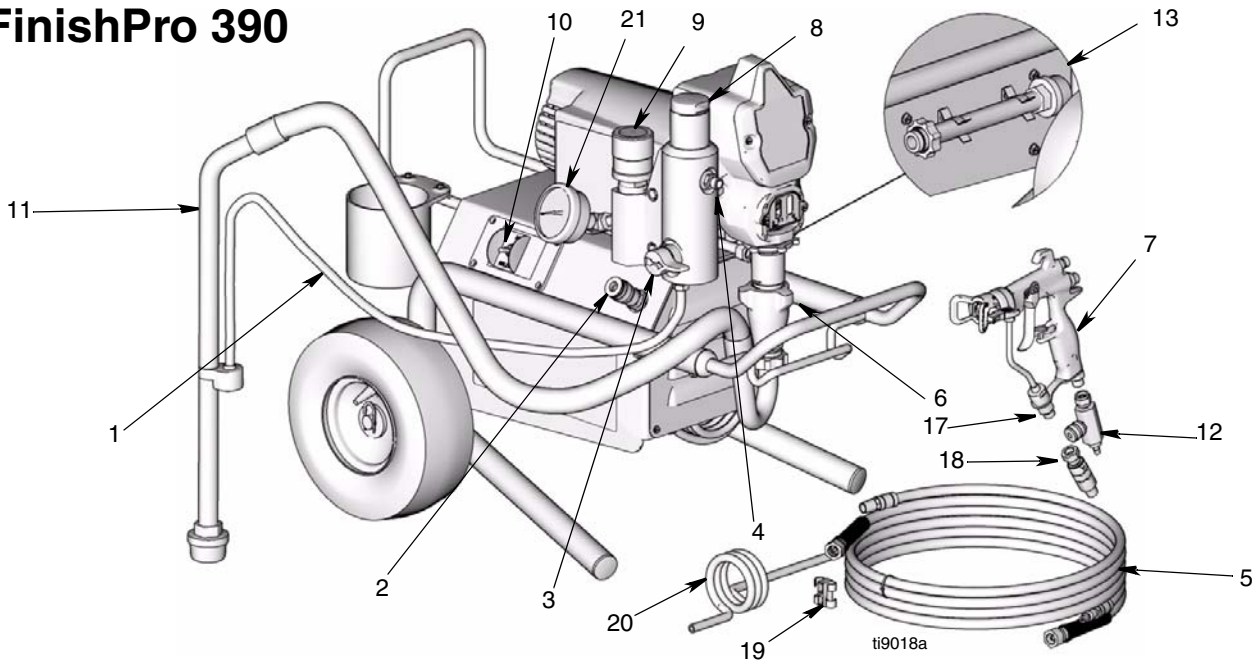

FinishPro 395

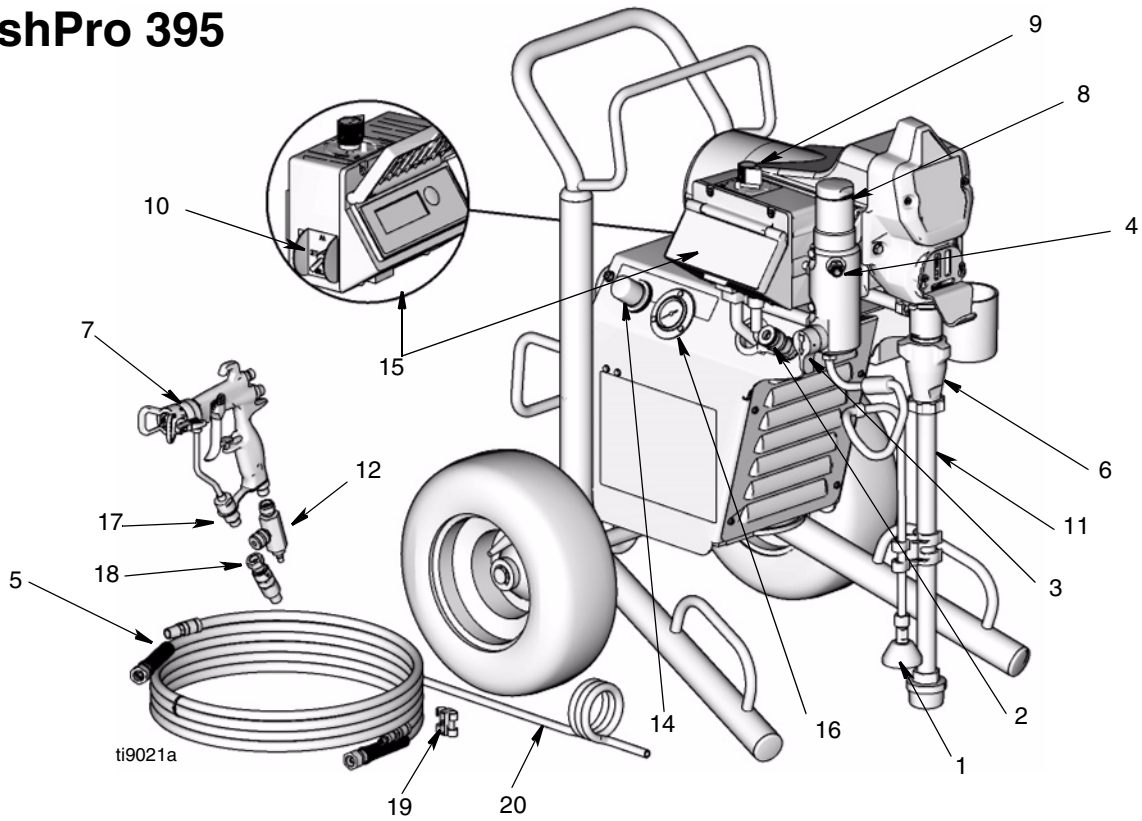

Component Identification

Item	Component
1	Prime/Drain Tube/Hose
2	Air Hose Connection
3	Prime/Spray Valve
4	Fluid Outlet
5	Air/Fluid Supply Hose
6	Displacement Pump
7	Gun (see manual)
8	Filter Manifold
9	Fluid Pressure Control
10	Power/Function Selector
11	Suction Tube
12	Gun Air Regulator
13	Direct Immersion Tube (FinishPro 390 model only)
14	Sprayer Air Pressure Regulator (FinishPro 395 model only)
15	Digital Display (FinishPro 395 model only)
16	Air Pressure Gauge (FinishPro 395 model only)
17	Gun Filter
18	High Pressure Paint Swivel
19	Hose T-clip
20	Flex Coil Air Hose
21	Fluid Pressure Gage (FinishPro 390 model only)

Installation

Grounding and Electric Requirements

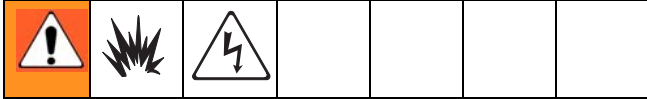

The sprayer cord includes a grounding wire with an appropriate grounding contact.

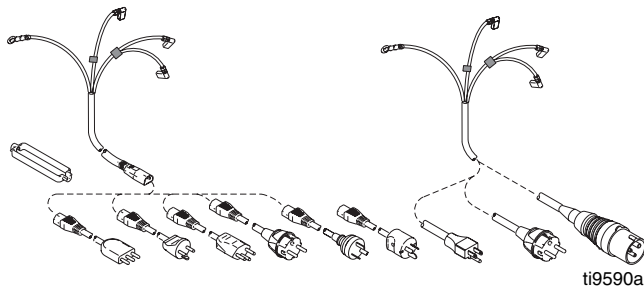

The sprayer requires:

110-120 Vac Sprayers: 100-120 Vac, 50/60 Hz, 15A, 1 phase, circuit with a grounding receptacle.

230 Vac Sprayers: 230 Vac, 50/60 Hz, 10A, 1 phase, circuit with a grounding receptacle.

Never use an outlet that is not grounded or an adapter.

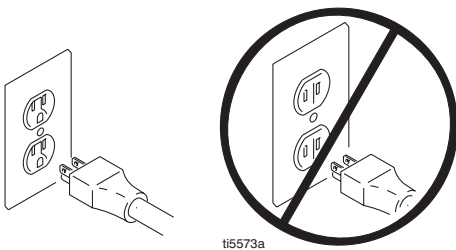

Do not use the sprayer if the electrical cord has a damaged ground contact. Only use an extension cord with an undamaged ground contact.

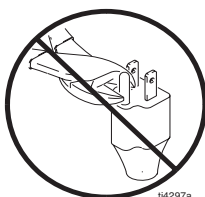

Recommended extension cords for use with this sprayer:

- 3-wire, 12 AWG (2.5 mm²) minimum, 300 ft. (90 m) maximum length.

 Smaller gauge or longer extension cords may reduce sprayer performance.

Spray gun: ground through connection to a properly grounded fluid hose and pump.

Fluid supply container: follow local code.

Solvent and Oil-based fluids: follow local code. Use only conductive metal pails placed on a grounded surface such as concrete. Do not place the pail on a non-conductive surface such as paper or cardboard, which interrupts grounding continuity.

Grounding the metal pail: connect a ground wire to the pail by clamping one end to pail and other end to ground such as a water pipe.

To maintain grounding continuity when flushing or relieving pressure: hold metal part of the spray gun firmly to the side of a grounded metal pail, then trigger the gun.



Pressure Relief Procedure



Follow this **Pressure Relief Procedure** whenever you are instructed to relieve pressure, stop spraying, check or service equipment or install or clean spray tip.

1. Set function selection switch to OFF and unplug sprayer.

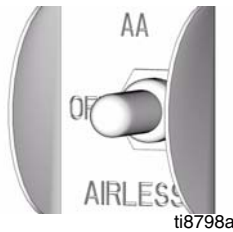

ti8798a

2. Turn pressure to lowest setting.

3. Hold gun against side of grounded metal flushing pail. Trigger gun to relieve pressure.



ti9270a

4. Turn prime valve down.

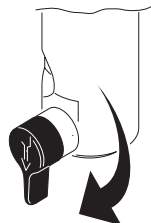

ti2719a

*If you suspect the spray tip or hose is clogged or that pressure has not been fully relieved after following the steps above, **VERY SLOWLY** loosen tip guard retaining nut or hose end coupling to relieve pressure gradually, then loosen completely. Clear hose or tip obstruction.*

5. Engage trigger safety lock on gun if unit is being shut down or left unattended.

General Repair Information



Flammable materials spilled on hot, bare, motor could cause fire or explosion. To reduce risk of burns, fire or explosion, do not operate sprayer with cover removed.

- Keep all screws, nuts, washers, gaskets, and electrical fittings removed during repair procedures. These parts usually are not provided with replacement kits.
- Test repairs after problems are corrected. If sprayer does not operate properly, review repair procedure to verify you did it correctly. See **Troubleshooting**, page 8.
- Overspray may build up in the air passages. Remove any overspray and residue from air passages and openings in the enclosures whenever you service sprayer.
- Do not operate sprayer without motor shroud in place. Replace if damaged. Motor shroud directs cooling air around motor to prevent overheating and insulates control board from accidental electric shock.

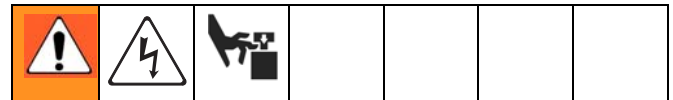

To reduce risk of serious injury, including electric shock:

- Do not touch moving or electric parts with fingers or tools while testing repair.
- Unplug sprayer when power is not required for testing.
- Install all covers, gaskets, screws and washers before you operate sprayer.

CAUTION

- Do not run sprayer dry for more than 30 seconds. Doing so could damage pump packings.
- Protect the internal drive parts of this sprayer from water. Openings in the cover allow for air cooling of the mechanical parts and electronics inside. If water gets in these openings, the sprayer could malfunction or be permanently damaged.
- Prevent pump corrosion and damage from freezing. Never leave water or water-base paint in sprayer in cold weather. Freezing fluids can seriously damage sprayer. Store sprayer with Pump Armor to protect sprayer during storage.
- Do not allow material to dry on gun air cap. Poor spray finish could result.

Troubleshooting



Problem	What To Check <i>(If check is OK, go to next check)</i>	What To Do <i>(When check is not OK, refer to this column)</i>
Sprayer Won't Operate		
Basic Fluid Pressure	1. Pressure control knob setting. Motor will not run if set at minimum (fully counter-clockwise).	Slowly increase pressure setting to see if motor starts.
	2. Spray tip or fluid filter may be clogged.	Relieve pressure , page 7. Then clear clog or clean gun filter. Refer to gun instruction manual, 311937.
Basic Mechanical	1. Pump frozen or hardened paint	Thaw sprayer if water or water-based paint has frozen in sprayer. Place sprayer in warm area to thaw. Do not start sprayer until thawed completely. If paint hardened (dried) in sprayer, replace pump packings. See page 13, Displacement Pump Replacement .
	2. Displacement pump connecting rod pin. Pin must be completely pushed into connecting rod and retaining spring must be firmly in groove or pump pin.	Push pin into place and secure with spring retainer. See page 13, Displacement Pump Replacement .
	3. Motor. Remove drive housing assembly. See page 15, Drive Housing Replacement . Try to rotate fan by hand.	Replace motor if fan won't turn. See page 34, Motor Replacement .
Basic Air Pressure	1. Power/function selector.	Ensure selection is AA.
	2. Spray air pressure regulator may be closed (FinishPro 395)	Pull air regulator to unlock and turn clockwise to open.
	3. Air valve at gun may be closed	Turn air regulator counter-clockwise to open.

<p>Problem</p>	<p>What To Check <i>(If check is OK, go to next check)</i></p>	<p>What To Do <i>(When check is not OK, refer to this column)</i></p>
<p>Basic Electrical <i>See wiring diagram, page 36</i></p>	<p>1. Electric supply. Meter must read 105-120 Vac for 110-120 Vac models and 210-255 Vac for 230 Vac models.</p>	<p>Reset building circuit breaker, replace building fuses. Try another outlet.</p>
	<p>2. Extension cord. Check extension cord continuity with volt meter.</p>	<p>Replace extension cord. Use shorter extension cord.</p>
	<p>3. Sprayer power supply cord. Inspect for damage such as broken insulation or wires.</p>	<p>Replace power supply cord. See page 21, Power Cord Replacement.</p>
	<p>4. Fuse (FinishPro 390). Check replaceable fuse on control board (next to ON/OFF switch).</p>	<p>Replace fuse after completing motor inspection. See page 23, Fuse Replacement.</p>
	<p>5. Motor leads are securely fastened and properly connected to control board.</p>	<p>Replace loose terminals; crimp to leads. Be sure terminals are firmly connected. Clean circuit board terminals. Securely reconnect leads.</p>
	<p>6. Motor thermal switch. Yellow motor leads must have continuity through thermal switch.</p>	<p>Replace motor. See page 34, Motor Replacement.</p>
	<p>7. Brush cap missing or loose brush lead connections.</p>	<p>Install brush cap or replace brushes if leads are damaged. See page 18, Motor Brush Replacement.</p>
	<p>8. Brush length which must be 1/4 in. (6mm) minimum. NOTE: Brushes do not wear at the same rate on both sides of motor. Check both brushes.</p>	<p>Replace brushes. See page 18, Motor Brush Replacement.</p>
	<p>9. Motor armature commutator for burn spots, gouges and extreme roughness.</p>	<p>Remove motor and have motor shop resurface commutator if possible. See page 34, Motor Replacement.</p>
	<p>10. Motor armature for shorts using armature tester (growler) or perform spin test, page 16.</p>	<p>Replace motor. See page 34, Motor Replacement.</p>
	<p>11. Pressure control not plugged in to control board.</p>	<p>Insert pressure control connector into control board.</p>

<p>Problem</p>	<p>What To Check <i>(If check is OK, go to next check)</i></p>	<p>What To Do <i>(When check is not OK, refer to this column)</i></p>
<p>Low Fluid Output</p>	<p>1. Worn spray tip.</p>	<p>Relieve pressure, page 7. Replace tip. Refer to gun instruction manual, 311937.</p>
	<p>2. Verify pump does not continue to stroke when gun trigger is released.</p>	<p>Service pump. See page 13, Displacement Pump Replacement.</p>
	<p>3. Prime valve leaking.</p>	<p>Relieve pressure, page 7. Then repair prime valve. See page 28, Pressure Control Replacement.</p>
	<p>4. Suction hose connections.</p>	<p>Tighten any loose connections. Check o-rings on suction hose swivel.</p>
	<p>5. Electric supply with volt meter. Meter must read 105-130 Vac for 110-120 Vac models and 210-255 for 240 Vac models. Low voltages reduce sprayer performance.</p>	<p>Reset building circuit breaker; replace building fuse. Repair electrical outlet or try another outlet.</p>
	<p>6. Extension cord size and length.</p>	<p>Replace with a correct, grounded extension cord. See page 6, Grounding and Electric Requirements.</p>
	<p>7. Leads from motor to circuit board for damaged or loose wire connectors. Inspect wiring insulation and terminals for signs of overheating.</p>	<p>Be sure male terminal pins are centered and firmly connected to female terminals. Replace any loose terminals or damaged wiring. Securely reconnect terminals.</p>
	<p>8. Worn motor brushes which must be 1/4 in. (6 mm) minimum.</p>	<p>Replace brushes. See page 18. Motor Brush Replacement.</p>
	<p>9. Motor brushes binding in brush holders.</p>	<p>Clean brush holders. Remove carbon dust by using compressed air to blow out brush dust.</p>
	<p>10. Low stall pressure. Turn pressure control knob fully clockwise.</p>	<p>Replace pressure control assembly. See page 28, Pressure Control Assembly Replacement.</p>
	<p>11. Motor armature for shorts by using an armature tester (growler) or perform spin test, page 16.</p>	<p>Replace motor. See page 34, Motor Replacement.</p>

Problem	What To Check <i>(If check is OK, go to next check)</i>	What To Do <i>(When check is not OK, refer to this column)</i>
Motor runs and pump strokes	1. Prime Valve Open.	Close prime valve.
	2. Paint supply.	Refill and reprime pump.
	3. Intake strainer clogged.	Remove and clean, then reinstall.
	4. Suction hose leaking air.	Tighten nut. Check o-rings on swivel.
	5. Intake valve ball and piston ball are seating properly.	See Pump Manual 309250. Strain paint before using to remove particles that could clog pump.
	6. Leaking around throat packing nut which may indicate worn or damaged packings.	See Pump Manual 309250.
	7. Pump rod damaged.	See Pump Manual 309250.
Motor runs but pump does not stroke	1. Displacement pump pin damaged or missing.	Replace pump pin if missing. Be sure retaining spring is fully in groove all around connecting rod. See page 13, Displacement Pump Replacement .
	2. Connecting rod assembly for damage.	Replace connecting rod assembly. See page 13, Displacement Pump Replacement .
	3. Gears or drive housing.	Inspect drive housing assembly and gears for damage and replace if necessary. See page 15, Drive Housing Replacement .
Motor is hot and runs intermittently	1. Be sure ambient temperature where sprayer is located is not more than 115°F (46°C) and sprayer is not located in direct sun.	Move sprayer to shaded, cooler area if possible.
	2. Motor has burned windings indicated by removing positive (red) brush and seeing burned adjacent commutator bars.	Replace motor. See page 34, Motor Replacement .
	3. Tightness of pump packing nut. Overtightening tightens packings on rod, restricts pump action and damages packings.	Loosen packing nut. Check for leaking around throat. Replace pump packings if necessary. See pump manual 309250.
Low air output at gun	1. Air valve at gun may be closed.	Turn air valve counter-clockwise to open.
	2. Sprayer air regulator may be closed (FinishPro 395)	Pull to unlock and turn air regulator clockwise to open.
	3. Air connections may be loose.	Check all connections for leaking air.

Problem	What To Check <i>(If check is OK, go to next check)</i>	What To Do <i>(When check is not OK, refer to this column)</i>
Low air output at gun	4. Damaged (leaking) air supply hose.	Replace air supply hose.
	5. Air intake filter clogged.	Clean or replace air intake filter kit.
	6. Mechanical air unloader stuck open.	Replace mechanical air unloader.
	7. Electrical air unloader stuck open.	Replace electrical air unloader.
Air compressor does not run	1. Power/function selector switch	Set function selector switch to AA; replace switch.
	2. Voltage to compressor below 105 Vac for 110 - 120 Vac models or below 210 Vac for 240 Vac models	Try another outlet. Reduce extension cord length or increase extension cord gauge.
	3. Loose power connections	Verify all connections are firm.
	4. Excessive head pressure (compressor hums)	Moisture frozen in air supply line.
	5. Excessive head pressure (compressor hums)	Wait for air pressure to bleed to zero.
	6. Excessive head pressure (compressor hums)	Electrical air unloader stuck closed. Replace electrical air unloader.
	7. Excessive head pressure (compressor hums)	Open air regulator (FinishPro 395) Install air line Do Startup , Operation Manual 311905
	8. Compressor thermal switch is open. Ensure ambient temperature is below 115 °F (46 °C).	Move sprayer to shaded, cooler area.
9. Low compressor performance.	Worn compressor; replace compressor with Compressor Service Kit 288723.	
Poor air spray pattern	1. Air cap air ports clogged.	Soak in solvent to clean.
	2. Air cap worn.	Replace air cap.
	3. Worn spray tip.	Relieve pressure , page 7. Replace tip. Refer to gun instruction manual, 311937.

Displacement Pump Replacement

See manual 309250 for pump repair instructions.

Removal



1. **Relieve pressure**, page 7. Unplug sprayer from outlet.
2. Loosen two screws (30) and rotate cover (44).

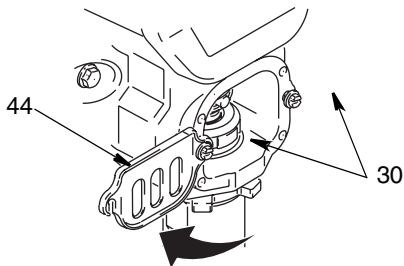

3. Loosen nut (A) and remove suction hose (35). Loosen nut (B) and remove the high pressure hose (14).

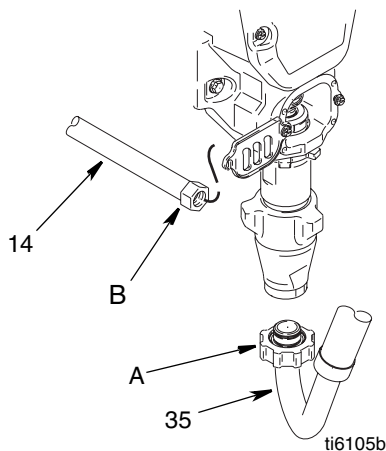

4. Cycle pump until pin (32) is in position to be removed.
5. Disconnect power cord from outlet.

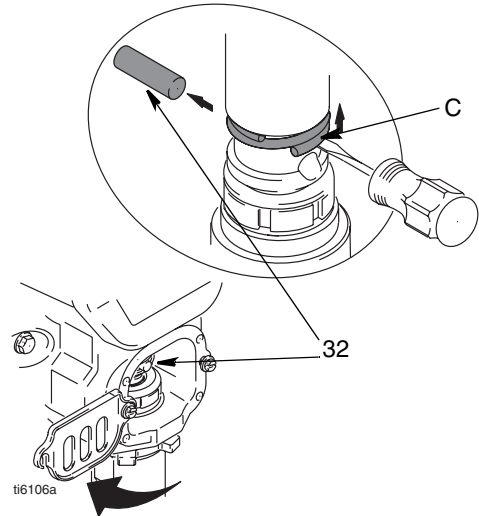

6. Using a flat screwdriver, push retaining spring (C) up. Push out pump pin (32).

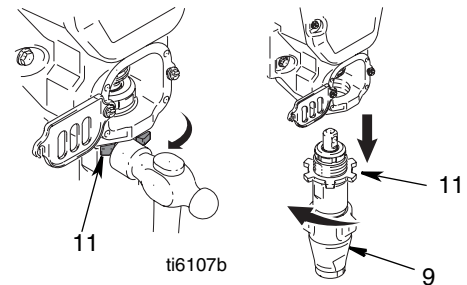

7. Using a hammer, loosen pump jam nut (11). Unscrew and remove pump (9).



Installation

						
<p>If pump pin works loose, parts could break off due to force of pumping action. Parts could project through air and result in serious injury or property damage.</p>						

CAUTION
<p>If the pump jam nut loosens during operation, the threads of the drive housing will be damaged.</p>

1. Extend pump piston rod full. Apply grease to top of pump rod at (D) or inside connecting rod (7). Install jam nut (11) on pump threads.

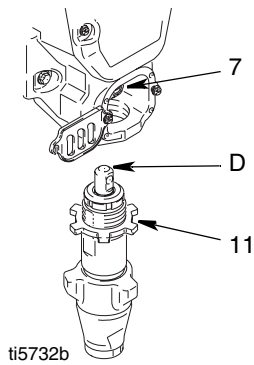

2. Install pump rod (D) into connecting rod (7).
3. Install pump pin (32). Verify retainer spring (C) is in groove over pump pin.

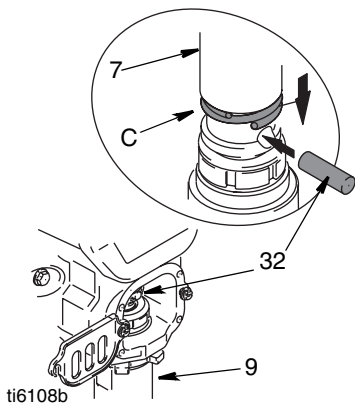

4. Push pump (9) up until pump threads engage.

5. Screw in pump until threads are flush with top of drive housing opening.

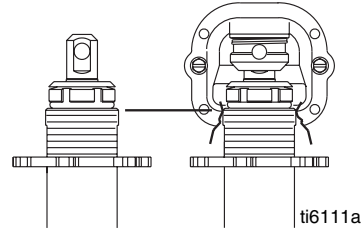

6. Align pump outlet (E) to back.

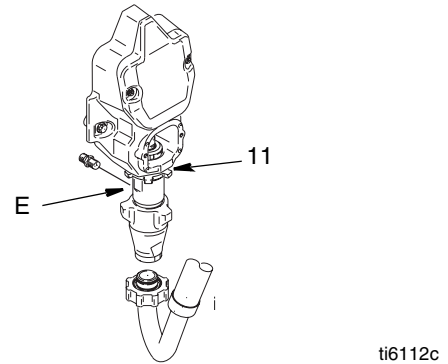

7. Screw jam nut (11) up onto pump until nut stops. Tighten jam nut by hand, then tap 1/8 to 1/4 turn with a 20 oz (maximum) hammer to approximately 75 ft-lb (102 N•m).
8. Install suction tube (35) and high pressure hose (14). Tighten nuts (A) and (B).

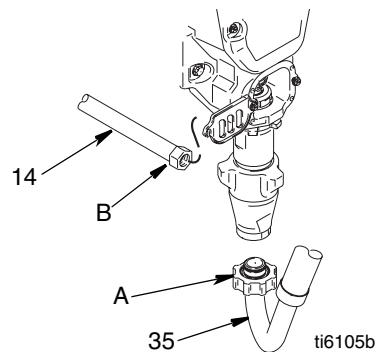

9. Fill packing nut with Graco TSL until fluid flows onto top of seal. Rotate cover (44). Tighten screws (30).

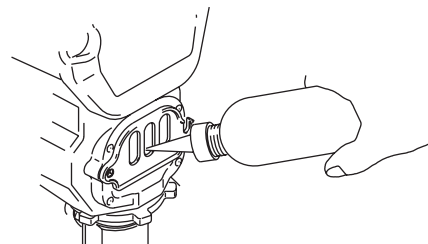

Drive Housing Replacement



Removal

1. Relieve pressure, page 7.
2. Remove pump (9). **Displacement Pump Replacement**, page 13.
3. Disconnect power cord from outlet.

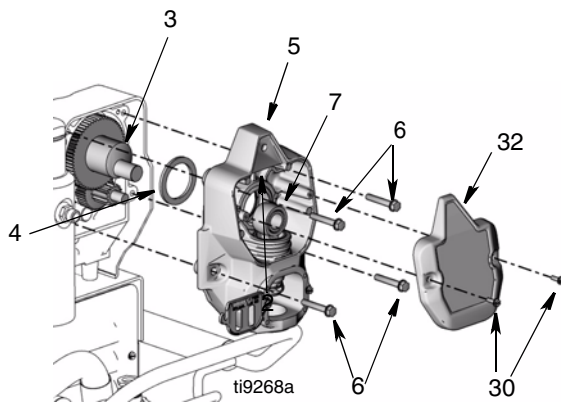

4. Remove two screws (30) and cover (32).
5. Remove four screws (6).
6. Pull drive housing (5) out of motor front endbell.
7. Remove gear cluster (2) and (3) and thrust bearing (4) from drive housing.

CAUTION

Do not drop gear cluster (3) and (2) when removing drive housing (5). Gear cluster may stay engaged in motor front endbell or drive housing.

Installation

1. Apply a liberal coat of grease to gears and needle bearing surfaces. Install thrust bearing (4) and gears (2) and (3) in front endbell housing.

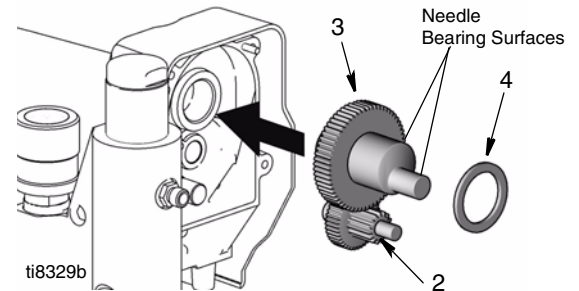

2. Push drive housing into front endbell housing. Insert gear crank (3) through hole in connecting rod (7).

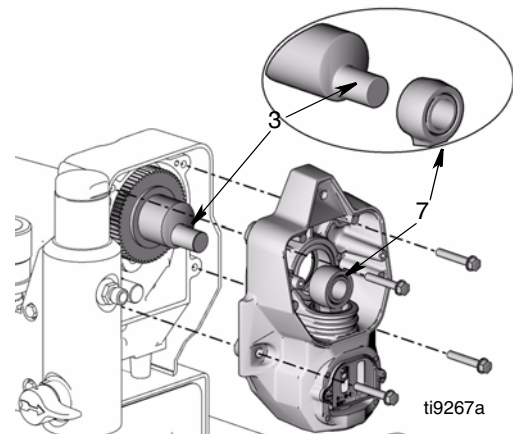

3. Install four screws (6).
4. Install cover (32) with two screws (30).
5. Install pump (9). **Displacement Pump Replacement**, page 13.

Spin Test

See Wiring Diagram, page 36.

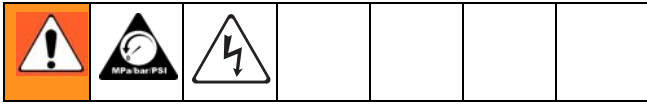

To check armature, motor winding and brush electrical continuity:

1. **Relieve pressure**, page 7. Disconnect power cord from outlet.
2. Remove two screws (30) and shroud (29).
3. Remove drive housing (5), page 15.
4. Disconnect motor connector (F).

Armature Short Circuit Test

Quickly turn motor fan by hand. If motor coasts two or three revolutions before complete stop, there are no electrical shorts. If motor does not spin freely, armature is shorted. Replace motor, page 34.

Armature, Brushes, and Motor Wiring Open Circuit Test (Continuity)

1. Connect red and black motor leads with test lead. Turn motor fan by hand at about two revolutions per second.
2. If uneven or no resistance, check for missing brush caps, broken brush springs, brush leads, and worn brushes. Repair as needed, page 18.
3. If still uneven or no resistance, replace motor, page 34.
4. Reattach motor connector (F).
5. Replace drive housing, page 15.
6. Replace shroud (29) and two screws (30).

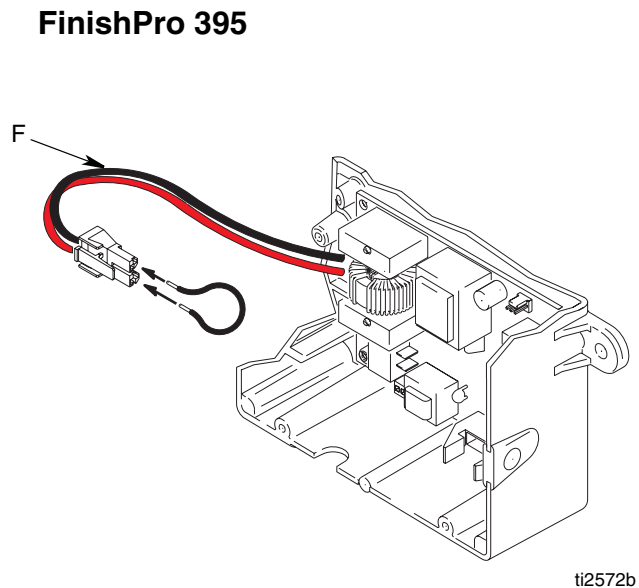
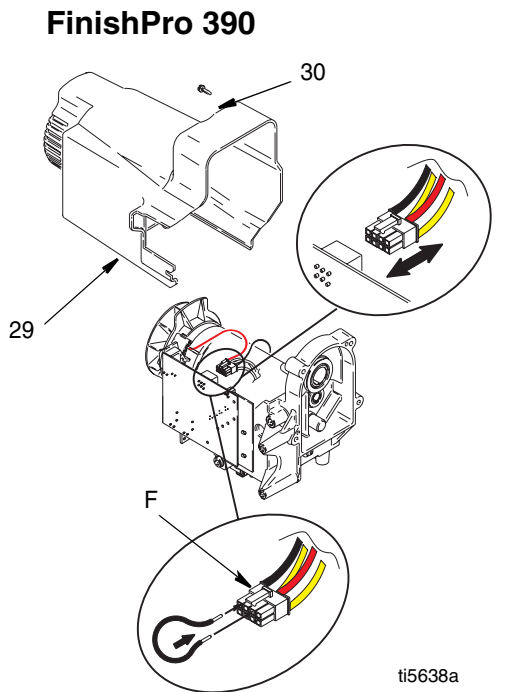

Fan Replacement

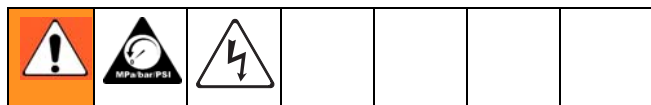

FinishPro 390

Removal

1. **Relieve pressure**, page 7. Disconnect power cord from outlet.
2. Remove two screws (30) and shroud (29).

3. Remove spring clip (1b) on back of motor.
4. Pull off fan (100).

Installation

1. Slide new fan (1a) in place on back of motor. Be sure blades of fan face motor as shown.
2. Install spring clip (1b).
3. Replace shroud (29) and two screws (30).

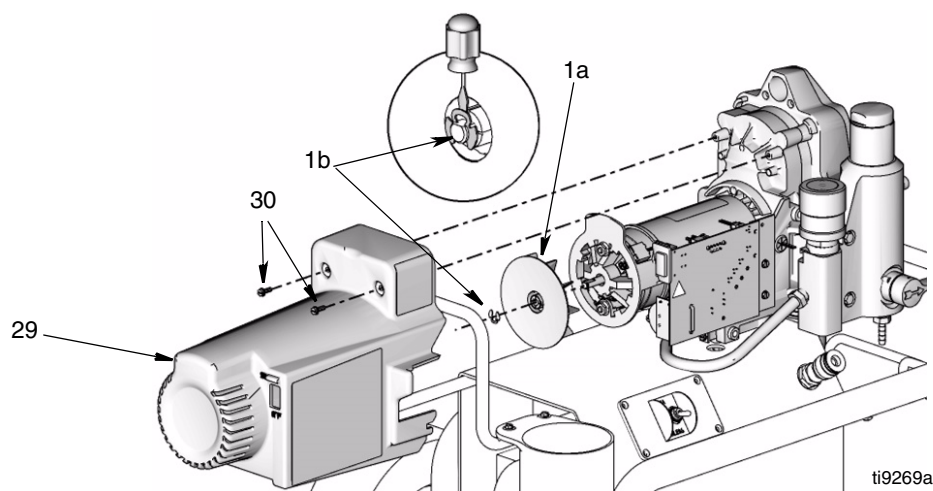

ti9269a

FinishPro 395

1. **Relieve pressure**, page 7. Disconnect power cord from outlet.
2. Remove four screws (12) and shroud (23).
3. Remove retaining ring (126) on fan (125).
4. Pull off fan.

Installation

1. Slide new fan (125) on back of motor. Be sure blades of fan face motor as shown.
2. Install retaining ring (126).
3. Replace shroud (23) and four screws (12).

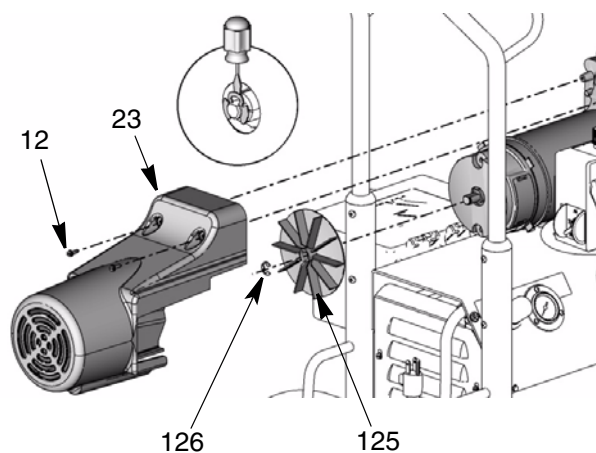

ti9604a

Motor Brush Replacement

See *Wiring Diagram*, page 36.

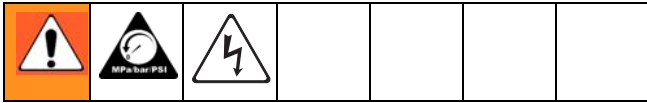

FinishPro 390

Removal

Replace brushes worn to less than 1/4 in. (6mm).

Brushes wear differently on each side of motor, check both sides.

1. **Relieve pressure**, page 7. Disconnect power cord from outlet.
2. Remove two screws (30) and shroud (29) (see illustration on page 16).
3. Disconnect motor connector (D) from control board (33).
4. Cut tie wrap (F).
5. Locate two yellow wires (C) (thermal leads). Cut each yellow wire at the center.
6. Using a flat screwdriver, pry off (two) brush caps (A). Remove brushes (B) from motor.
7. Discard old brush harness.
8. While rotating fan by hand, using compressed air, blow air into positive (top) brush holder to remove brush dust.

 To contain the dust, turn on your shop Vac. Place the end of the hose over the negative (lower) brush holder while blowing compressed air into the positive (top) brush holder.

Installation

 Use all new parts included in your brush kit. Do not reuse old parts if new replacement parts are provided.

1. With wires facing toward front of motor, install new brushes (B) in motor. Be sure to install the positive (red) brush lead in the top of the motor (as shown) and the negative (black) brush lead in the side of the motor.

2. Push each cap (A) into place over brush. Orient each cap with the 2 projections on either side of the brush lead. You will hear a “snap” when cap is securely in place.
3. Using a wire stripper, strip off wire insulation approximately 1/4 inch (6 mm) from the end of each yellow wire (C) to the motor.
4. Insert stripped end into end of a butt splice (E) on new brush assembly.
5. Use a crimping tool to squeeze the ends of the butt splice (E) tightly around each wire. Pull gently on each wire to be sure it will not pull out of the butt splice.
6. Using new tie wrap (F) from kit, wrap tie around motor and wires only. Trim off excess. Be sure pressure hose and wire leads are not caught in tie wrap.
7. Reconnect motor connector (D) to control board (33).

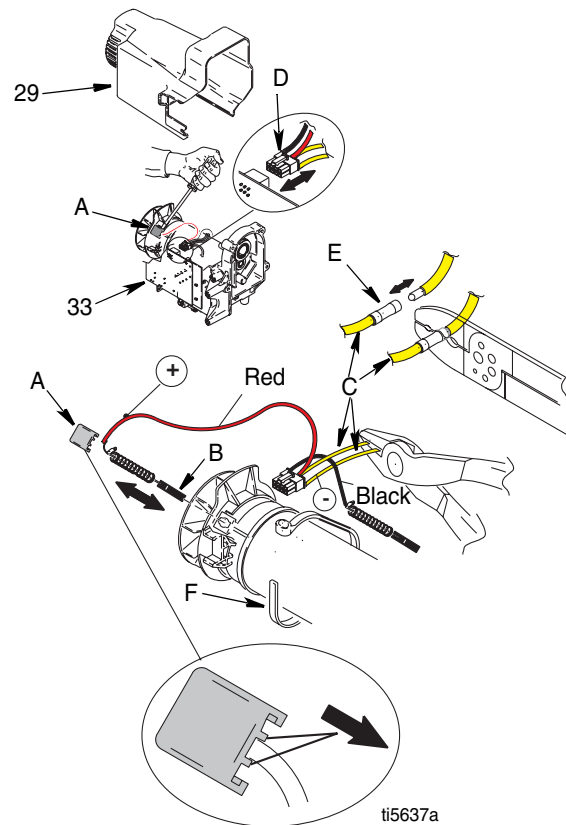

8. Replace shroud (29) and two screws (30) (see illustration, page 16).

Motor Brush Replacement

FinishPro 395

Removal

Replace brushes worn to less than 1/2 in. Brushes wear differently on each side of motor, check both sides. Brush Repair Kit 287735 is available.

1. Read General Repair Information, page 7.



2. Relieve pressure, page 7.
3. Remove motor shroud and two inspection covers (A).

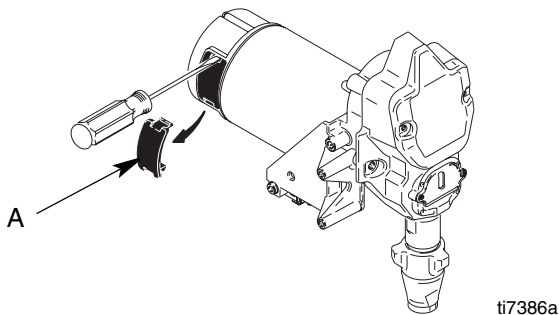

4. Push clip spring (B) to release hook (C) from brush holder (D). Pull out spring clip (B).
5. Pull brush lead (E) off terminal (F). Remove brush (G).

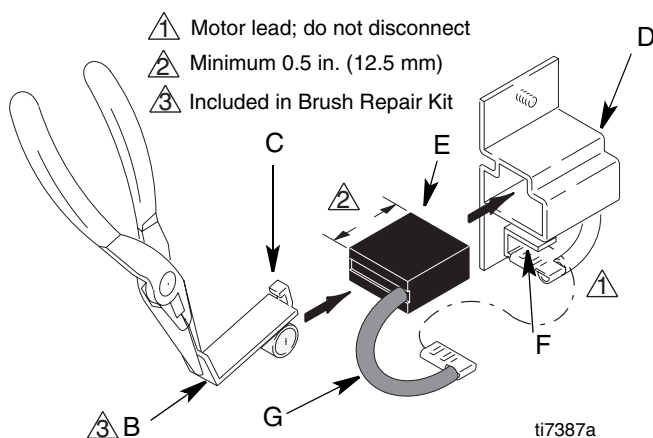

6. Inspect commutator for excessive pitting, burning, or gouging. A black color on commutator is normal. Have commutator resurfaced by a motor repair shop if brushes wear too fast.

Installation

CAUTION

When installing brushes, follow all steps carefully to avoid damaging parts.

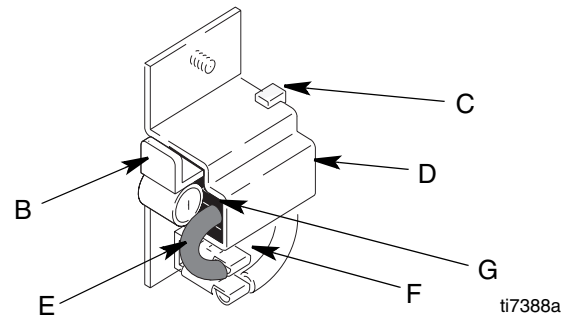

1. Install new brush (G) with lead into brush holder (D).
2. Slide brush lead (E) onto terminal (F).
3. Install spring clip (B). Push down to set hook (C) into brush holder (D).
4. Repeat for other side.
5. Test brushes.
 - a. Remove pump. **Displacement Pump Replacement**, page 13.
 - b. With sprayer OFF, turn pressure control knob fully counter-clockwise to minimum pressure. Plug in sprayer.
 - c. Turn sprayer ON. Slowly increase pressure until motor is at full speed.

CAUTION

Do not run sprayer dry for more than 30 seconds while checking brushes to avoid damaging displacement pump packings.

6. Install brush inspection covers (A) and gaskets.
7. Break in brushes.
 - a. Operate sprayer 1 hour with no load.
 - b. Install pump. **Displacement Pump Replacement**, page 13.

Control Board Replacement

See *Wiring Diagram*, page 36.

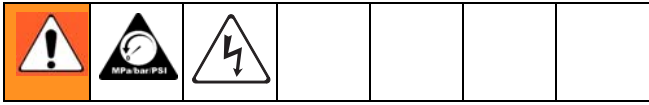

FinishPro 390

Removal

1. **Relieve pressure**, page 7. Disconnect power cord from outlet.
2. Remove two screws (30) and shroud (29) (see illustration, page 16).
3. Disconnect pressure switch connector (A) from control board (33).

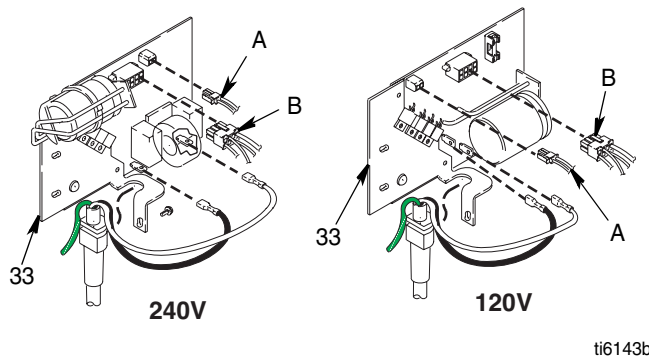

4. Disconnect motor connector (B) from control board (33).
5. Remove three screws (30) securing control board to housing (two are located on the front and one on the back next to the power cord).

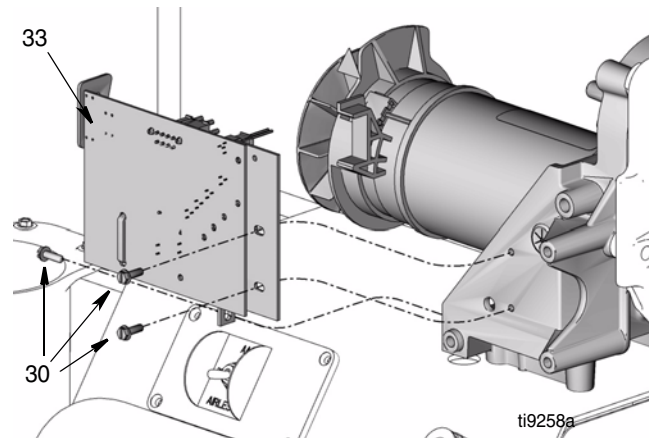

6. Pull control board out slightly and then slide it back and off of frame.

Make sure power cord is free and not wrapped around cord wrap.

7. Remove grommet and wires from strain relief.

Ground wire will remain attached to sprayer with grounding screw.

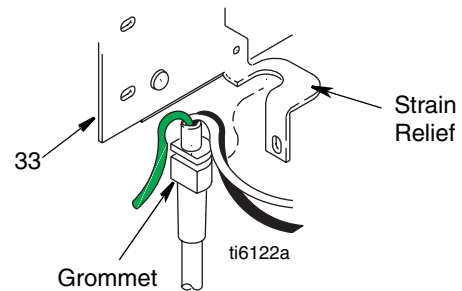

8. Remove two power cord connectors (C) from control board.

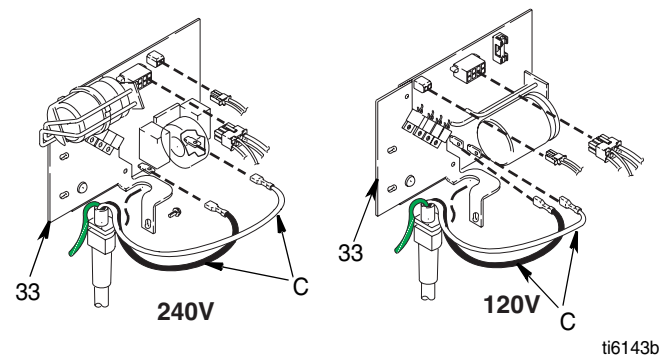

Installation

1. Position grommet and power cord wires through strain relief in control board (33).

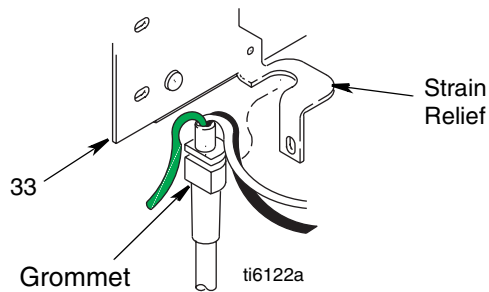

2. Connect the power cord connectors to the correct terminals indicated on the control board (120V, black and white, 240V, blue and brown) on control board (33).

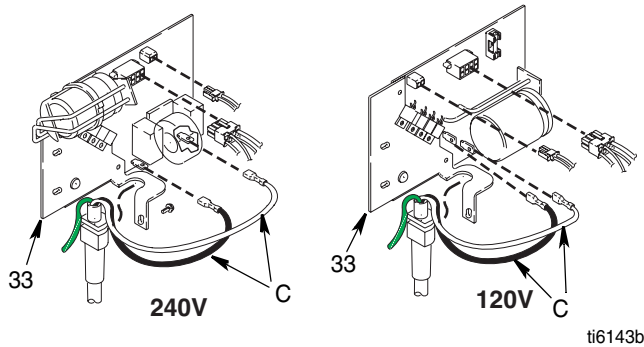

3. Carefully slide control board back into place on the side of the motor frame.

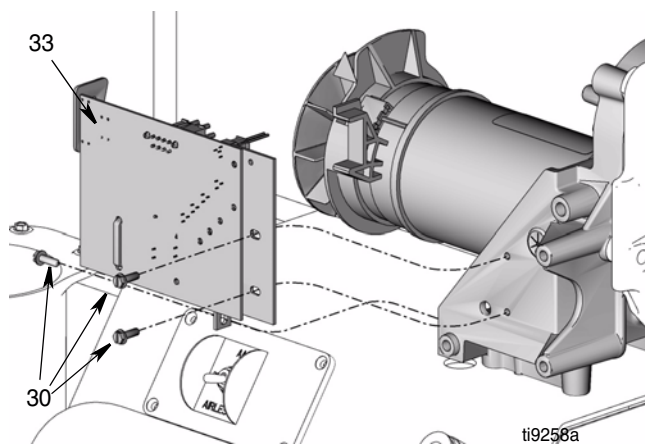

4. Install three screws (30). Torque to 30-35 in-lb (3.4-3.9 N.m).

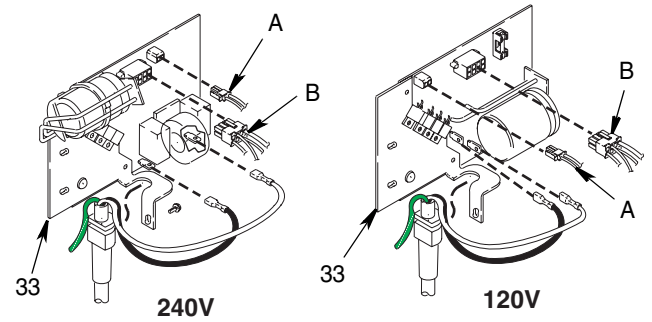

5. Attach motor connector (B) and pressure control assembly connector (A).
6. Install shroud (29) and two screws (30) (see illustration, page 16).

FinishPro 395

See Wiring Diagram, page 36.

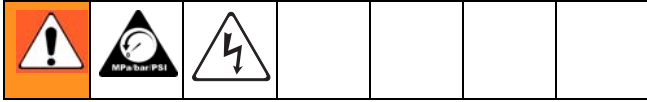

Removal

1. **Relieve pressure**, page 7. Disconnect power cord from outlet.
2. Remove four screws (12) and cover (50).
3. Disconnect all leads to motor control board (49).
4. Remove screws (6) and motor control board.

Installation

1. Clean pad on rear of motor control board (49). Apply small amount of thermal compound to pad.
2. Install motor control board with screws (6).
3. Connect all leads to motor control board.
4. Bundle and tie all loose wires so none are in contact with inductor coil.
5. Install cover (50) with four screws (6).

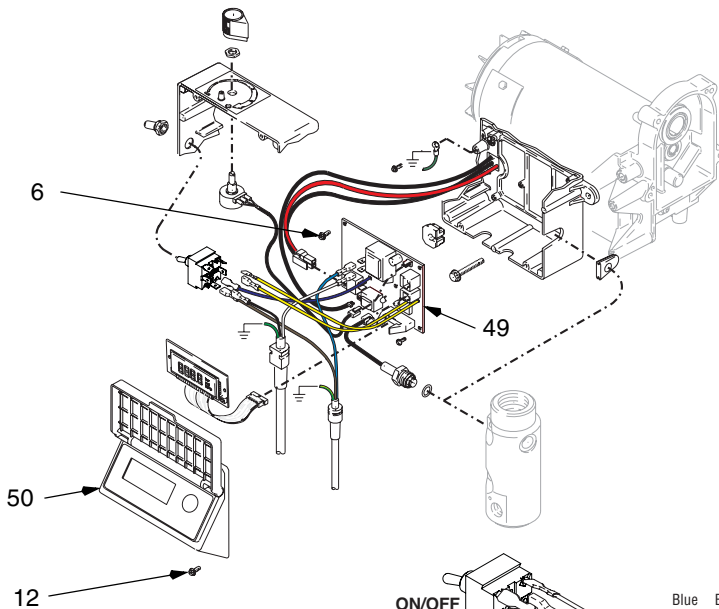

⚠ Yellow wires not used on 240V

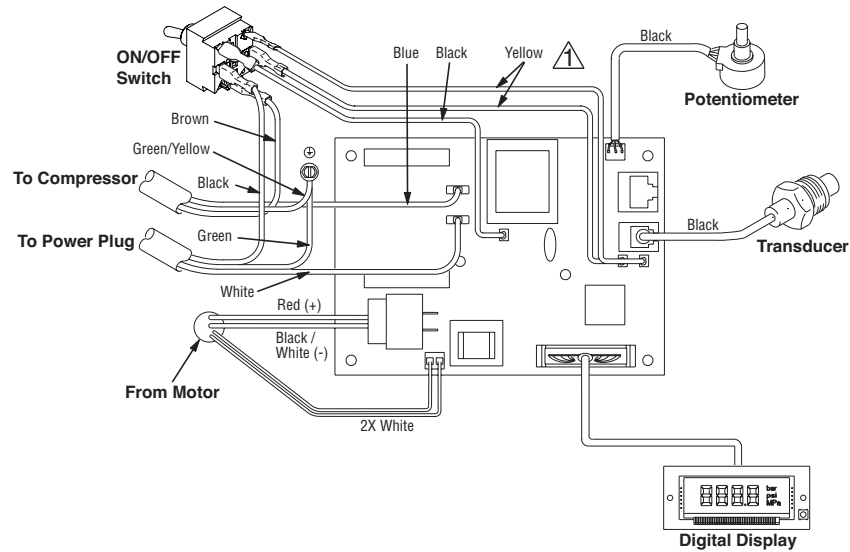

ti9715a

On/Off Switch Replacement

See Wiring Diagram, page 36.

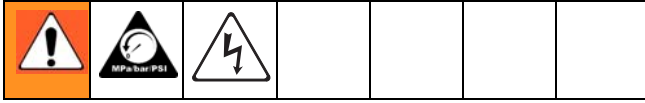

FinishPro 395

100/120/110/240 Vac

1. **Relieve pressure**, page 7.
2. Remove four screws (12) and pressure control cover (50).

Note: Tag wires before removing to ensure wires are identifiable when assembling.

3. Disconnect three wires (A) from ON/OFF switch (58).
4. Remove toggle boot/nut (30).
5. Remove two yellow wires (B) from ON/OFF switch. Remove ON/OFF switch.

Installation

1. Connect two yellow wires (B) to ON/OFF switch (58).
2. Install new ON/OFF switch (58). Install toggle boot/nut (30).
3. Connect three wires (A) to ON/OFF switch.
4. Install pressure control cover (50) with four screws (12).

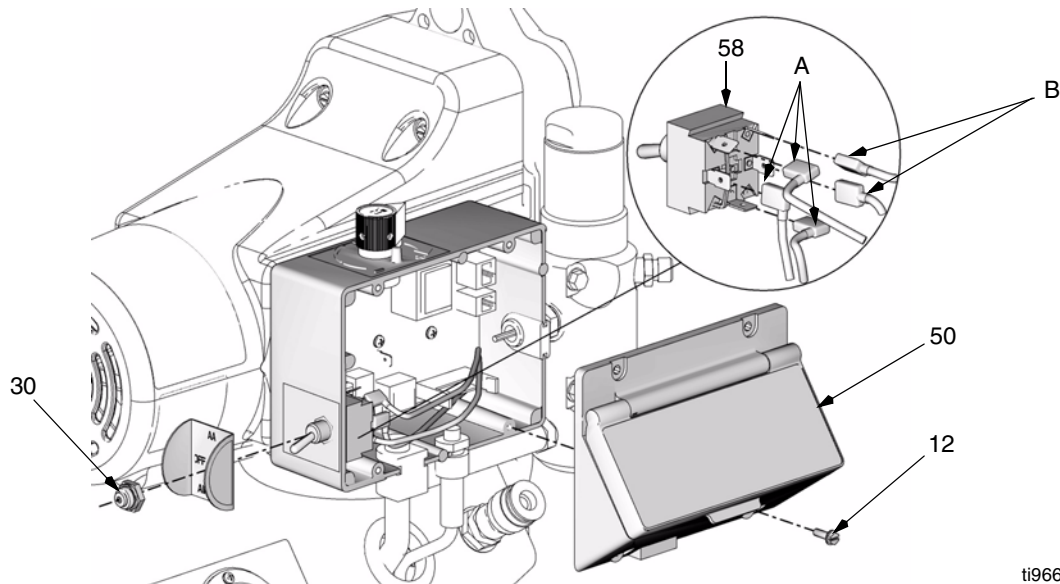

ti9665a

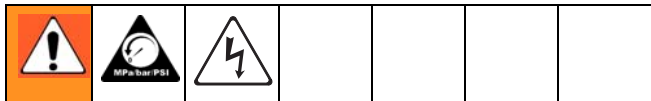

3. Disconnect three wires (A) from ON/OFF switch (58).
4. Remove toggle boot/nut (30). Remove ON/OFF switch (58).

FinishPro 390

100/120 Vac

Removal

1. **Relieve pressure**, page 7.
2. Remove four screws (12) and switch box cover (50).

Note: Tag wires before removing to ensure wires are identifiable when assembling.

Installation

1. Install new ON/OFF switch (58). Install toggle boot/nut (30).
2. Connect three wires (A) to ON/OFF switch (58).
3. Install switch box cover (50) with four screws (12).

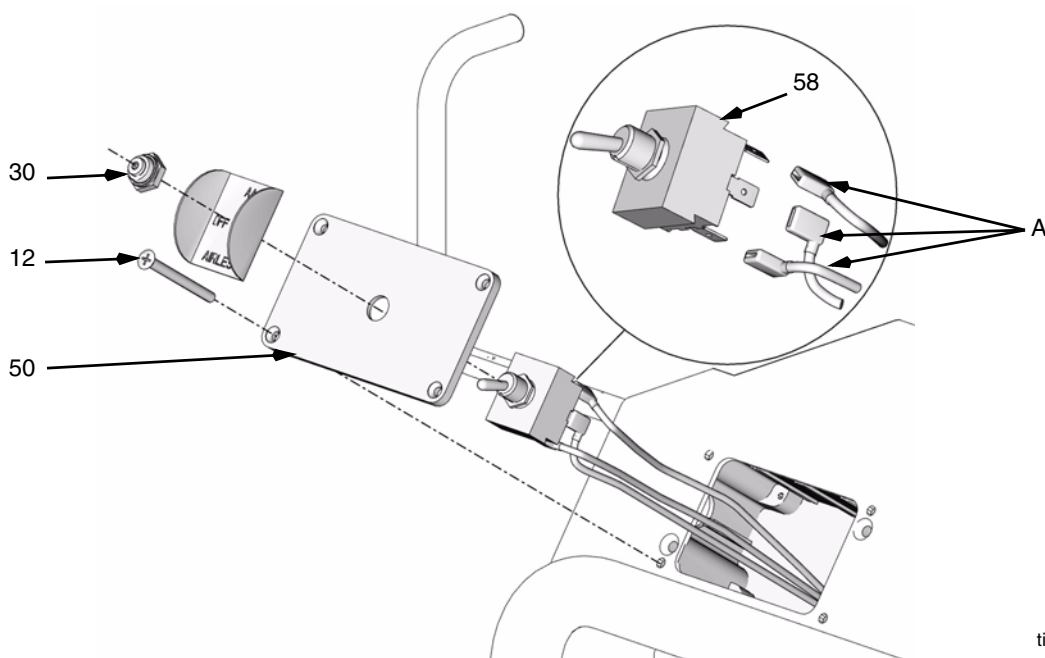

ti9649a

Fuse Replacement

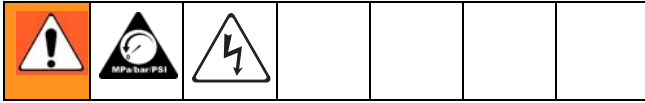

2. Remove two screws (30) and shroud (29) (see illustration, page 16).
3. Remove fuse from control board.

FinishPro 390 only

Removal

1. **Relieve pressure**, page 7. Disconnect power cord from outlet.

Installation

1. Install new fuse on control board.
2. Install shroud (29) and two screws (30) (see illustration, page 16).

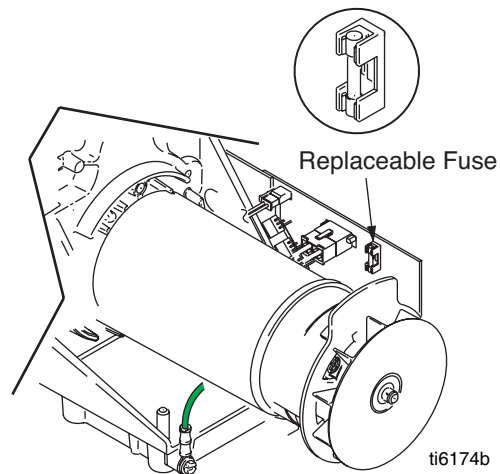

Removing and Installing Air Filter



Removal

1. **Relieve pressure**, page 7. Disconnect power cord from outlet.
2. **FinishPro 390:** Unscrew filter (D) from back of sprayer. Install new filter from Compressor Filter Kit 288724.

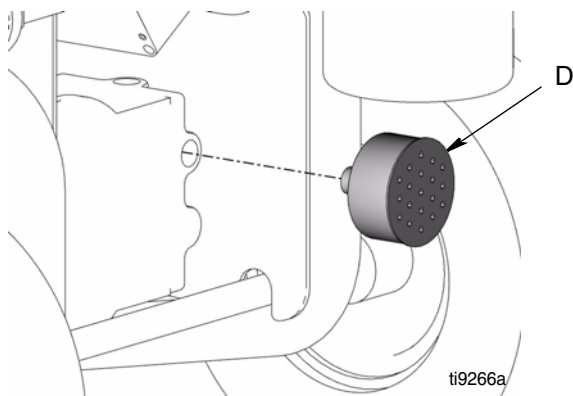

FinishPro 395:

- a. Remove four screws (12) from back louvered cover (64).
- b. Unscrew filter (D) from back of sprayer. Install new filter from Compressor Filter Kit 288724.
- c. Install back cover (64) with four screws (12).

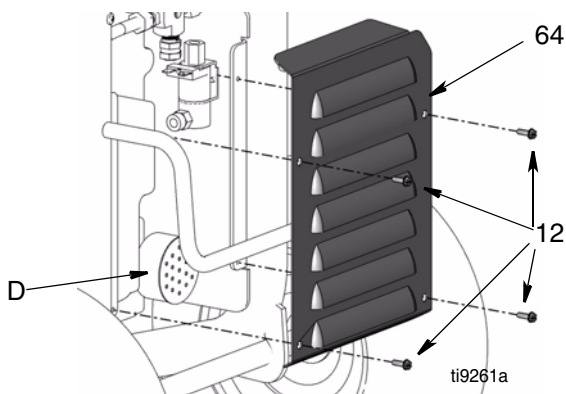

Compressor Replacement and Repair



- To repair compressor, use Compressor Service Kit 288723. Refer to Thomas Compressor manual provided.
- Replace compressor piston assembly, use Kit 288723.

Removing Compressor from Sprayer

1. **Relieve pressure**, page 7. Disconnect power cord from outlet.
2. Remove front and back louvers from sprayer.

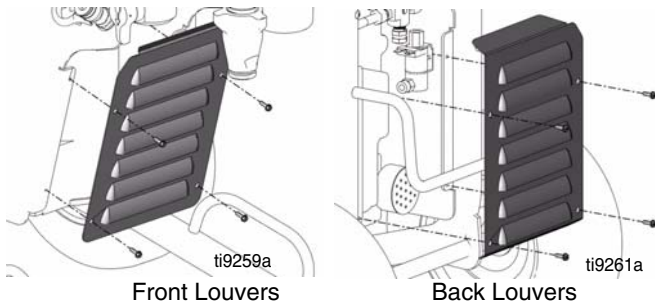

3. Disconnect air fitting from compressor.



4. Disconnect electrical connection from solenoid valve.

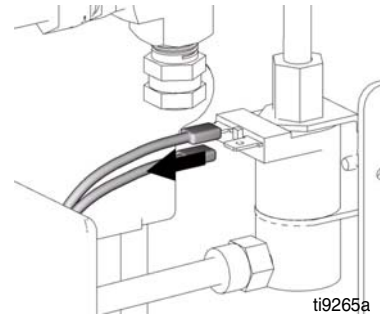

5. Remove compressor from sprayer. Follow instructions provided with your repair kit.

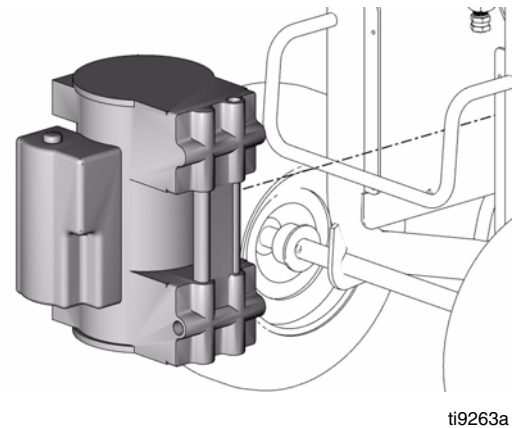

Pressure Control Replacement: FinishPro 390

See Wiring Diagram, page 36.

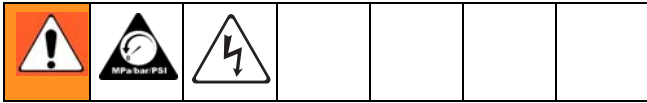

Removal

1. **Relieve pressure**, page 7. Disconnect power cord from outlet.
2. Remove two screws (30) and shroud (29) (see illustration, page 16).
3. Disconnect pressure switch connector (A) from control board (33).
4. Remove tape (22) holding wires to manifold.
5. Pull wires back through hole (K) in housing.

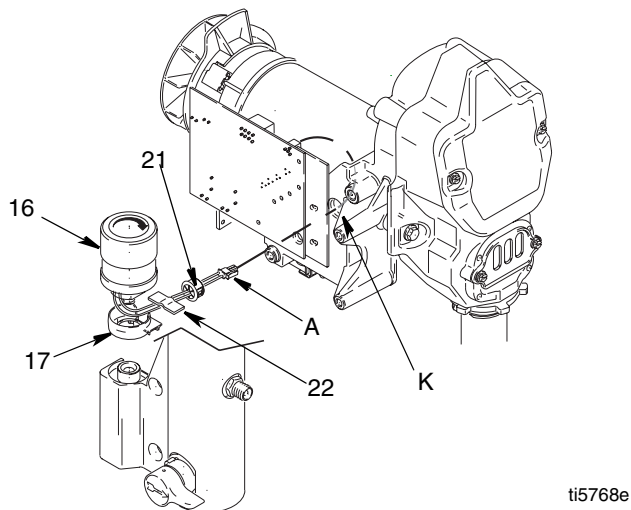

ti5768e

6. Turn the pressure control knob (16) counter clockwise as far as you can to access the flats on either side of the pressure control assembly.
7. Using a 1 in. (26 mm) wrench loosen and unscrew pressure control assembly.

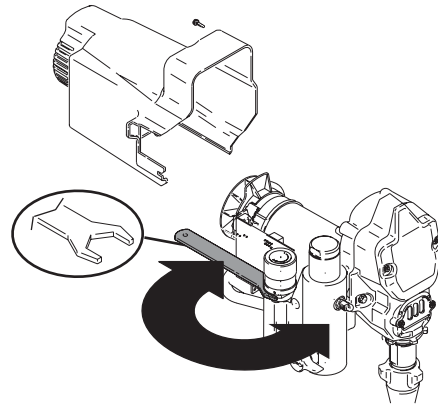



ti5766c

 If you plan to reuse the pressure control assembly, be very careful not to damage or tangle the wires while unscrewing the assembly.

8. Remove pressure control assembly.

Installation

 Inspect pressure control assembly before installation to verify the o-ring is installed and in place.

1. Align grommet collar (17) on fluid manifold so opening faces toward motor.
 2. Apply Loctite® to pressure control assembly threads (16).
 3. Screw pressure control assembly (16) into manifold and torque to 150 in-lb (17.0 N.m).
-  Be careful when tightening pressure control knob that wires do not get pinched between the pressure control assembly and fluid manifold.
4. Wrap wires around knob and feed through slot in grommet (21).
 5. Insert grommet (21) in hole (K) in housing. Secure wires to manifold housing with tape (22).
 6. Reconnect pressure switch connector (A) to control board (33).
 7. Install shroud (29) and two screws (30) (see illustration, page 15).

Motor Control Board Diagnostics: FinishPro 395

CAUTION
Do not allow sprayer to develop fluid pressure without transducer installed. Leave drain valve open if test transducer is used.

- Keep new transducer on hand for use for test.
- Refer to Digital Display Messages, page 30.

1. Relieve pressure, page 7 and unplug sprayer.
2. Remove screws and cover.
3. Turn ON/OFF switch, ON.
4. Observe LED operation and reference following table:

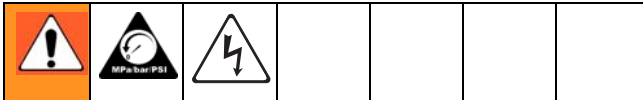

LED Blinks	Sprayer Operation	Indicates	What To Do
Once	Sprayer runs	Normal operation	Do nothing
Two times repeatedly	Sprayer shuts down and LED continues to blink two times repeatedly	Run away pressure. Pressure greater than 4500 psi (310 bar) or damaged pressure transducer	Replace motor control board or pressure transducer
Three times repeatedly	Sprayer shuts down and LED continues to blink three times repeatedly	Pressure transducer is faulty or missing	Check transducer connection. Open drain valve. Substitute new transducer for transducer in sprayer. If sprayer runs, replace transducer
Four times repeatedly	Sprayer shuts down and LED continues to blink four times repeatedly	Line voltage is too high	Check for voltage supply problems
Five times repeatedly	Sprayer does not start or shuts down and LED continues to blink five times repeatedly	Motor fault	Check for locked rotor, shorted wiring or disconnected motor. Repair or replace failed parts.

Digital Display Messages: FinishPro 395

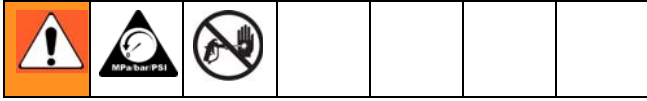

- No display does not mean the sprayer is not pressurized. Relieve pressure before repair.

<i>Display</i>	<i>Sprayer Operation</i>	<i>Indicates</i>	<i>What To Do</i>
No Display	Sprayer stops. Power is not applied. Sprayer may be pressurized.	Loss of power.	Check power source. Relieve pressure before repair or disassembly.
3000 psi 210 bar 21 MPa	Sprayer is pressurized. Power is applied. (Pressure varies with tip size and pressure control setting.)	Normal operation.	Spray.
E=02	Sprayer may continue to run. Power is applied.	Pressure greater than 4500p psi (310 bar, 31 mpa) or a pressure transducer is faulty.	Replace pressure control board or pressure transducer.
E=03	Sprayer stops. Power is applied.	Pressure transducer faulty, bad connection or broken wire.	Check transducer connection. Open drain valve. Substitute new transducer for transducer in sprayer. If sprayer runs, replace transducer.
E=04	Sprayer stops. Power is applied.	Line voltage too high.	Check for voltage supply problem.
E=05	Sprayer does not start or stops. Power is applied.	Motor fault.	Check for locked rotor, shorted wiring or disconnected motor. Repair or replace failed parts.
----	Power is applied.	Pressure is less than 200 psi (14 bar, 1.4 MPa)	Increase pressure if desired. Drain valve may be open.
EMPTY	Sprayer stops. Power is applied.	Empty paint pail. Loss of pressure.	Refill paint pail. Check for leaks or clogged pump inlet. Repeat Startup procedure.

Pressure Control Transducer: FinishPro 395

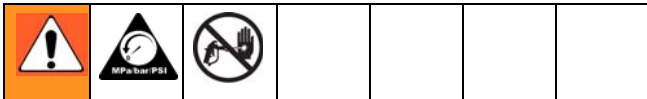

- Remove pressure control transducer and packing o-ring from filter housing.

Installation

- Install packing o-ring and pressure control transducer in filter housing. Torque to 30-35 ft-lb.
- Thread transducer lead plastic connector up through transducer grommet.
- Install filter housing with two screws.
- Connect lead to motor control board.
- Install cover with screws.

Removal

- Relieve pressure, page 7. Unplug sprayer.
- Remove screws and cover.
- Disconnect lead (E) from motor control board.
- Remove two screws and filter housing.
- Thread transducer lead plastic connector down through transducer grommet.

Pressure Adjust Potentiometer: FinishPro 395

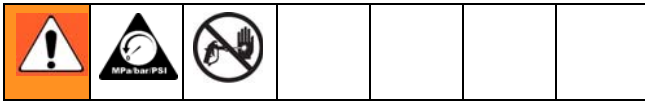

Removal

1. **Relieve pressure**, page 7. Unplug sprayer.
2. Remove screws and cover.
3. Disconnect all leads from motor control board.
4. Remove potentiometer knob, nut, and pressure adjust potentiometer.

Installation

1. Install pressure adjust potentiometer, nut and potentiometer knob.
 - a. Turn potentiometer fully clockwise.
 - b. Install knob at full clockwise position.
2. Connect all leads to motor board.
3. Install cover with screws.

Stored Data

The SmartControl contains stored data to assist with troubleshooting and maintenance. To view this stored data on the digital display, proceed as follows:

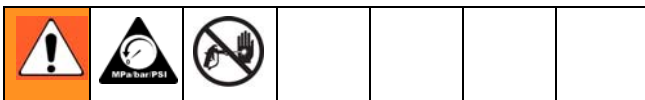

1. **Relieve pressure**, page 7.
2. Plug in sprayer.
3. Hold down digital display button and turn sprayer ON.
4. Release display button about 1 second after turning on sprayer.

Sprayer model number displays for a few seconds and then data point 1 displays.

5. Push display button and next data point displays.

6. Turn sprayer OFF and then ON to leave in stored data mode.

Data Point	Definition
1	Number of hours power switch has been ON with power applied
2	Number of hours motor has been running
3	Last error code. Press and hold display button to clear error code to E=00
4	Software revision

Drain Valve Replacement

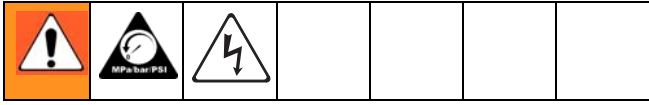

Removal

1. **Relieve pressure**, page 7. Disconnect power cord from outlet.
2. Using a punch and hammer, tap pin (26) out of drain handle (25).
3. Pull drain handle (25) and base (24) off drain valve (23).
4. Using a wrench, loosen drain valve (23) and remove it from manifold (15).

Installation

 Before installing new drain valve, be sure old gasket (23a) and seat (23b) are not still inside manifold.

1. Thread drain valve (23) into manifold (15) opening.
2. Hand tighten securely. Using a wrench, torque to 120 to 130 in-lb.
3. Push base (24) over drain valve (23) and then drain handle (25) over base (24).
4. Replace pin (26) in drain handle (25). If necessary, use a hammer to tap it in place completely.

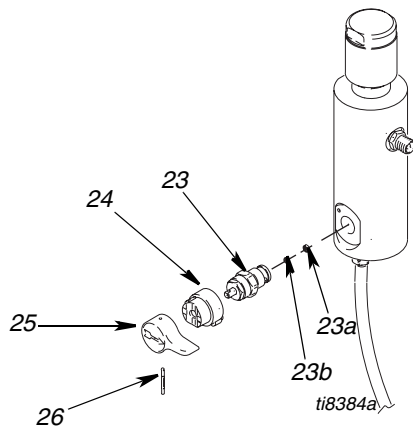

Drain Line Removal/Replacement

FinishPro 390

Removal

To remove the drain line (40) from the manifold:

1. Cut drain line (40) from barbed fitting (20).
2. Unscrew barbed fitting (20) from manifold.

 If you replace the manifold and reuse the existing barbed fitting (20) and drain line (40), cut the remaining drain line material off the end of the barbed fitting (20) with a sharp knife.

Installation

1. Screw barbed fitting (20) into manifold.
2. Push drain line (40) onto barbed fitting (20).

 To make the drain line more pliable and easier to install on barbed fitting, heat drain line (40) end with a hair dryer or place end in hot water a few seconds.

FinishPro 395

Removal: Unscrew drain line (55) from filter manifold (15).

Installation: Screw drain line (55) into filter manifold (15).

FinishPro 390

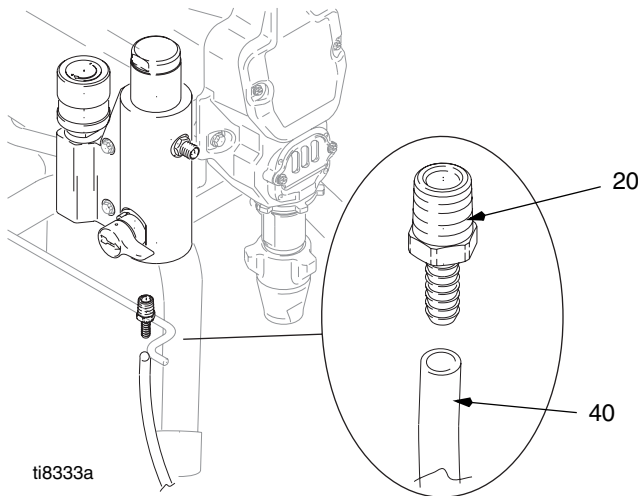

FinishPro 395

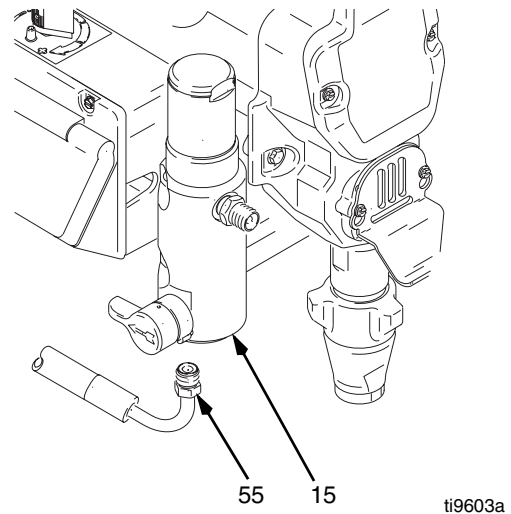

Motor Replacement

See *Wiring Diagram*, page 36.

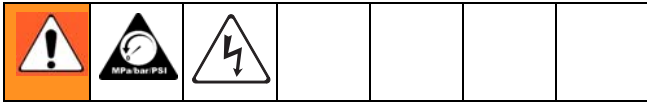

CAUTION

Do not drop gear cluster (3) and (2) when removing drive housing (5). Gear cluster may stay engaged in motor frontend bell or drive housing.

FinishPro 390

Removal

1. **Relieve pressure**, page 7. Disconnect power cord from outlet.
2. Remove pump (9). **Displacement Pump Replacement**, page 13.
3. Remove drive housing, **Drive Housing Replacement**, page 15.
4. Remove two screws (6) and manifold (15).
5. Disconnect all leads from board (33) and remove control board. **Control Board Replacement, FinishPro 390, Removal**, page 19.

6. Remove ground wire (G) from motor endbell.
7. Remove four screws (6) and motor (1) from frame (45).

Installation

1. Install new motor (1) on frame (45) with four screws (6).
2. Install manifold (15) with two screws (6).
3. Install control board (33) with three screws (30). Connect all leads to board. See **Control Board Replacement, FinishPro 390, Installation**, page 19 and **Wiring Diagram**, page 36.
4. Connect ground wire (G) to motor with green ground screw (31).
5. Install Drive Housing. **Drive Housing Replacement**, page 15.
6. Install pump (9). **Displacement Pump Replacement**, page 13.
7. Install shroud (29) with two screws (30) (see illustration, page 16).

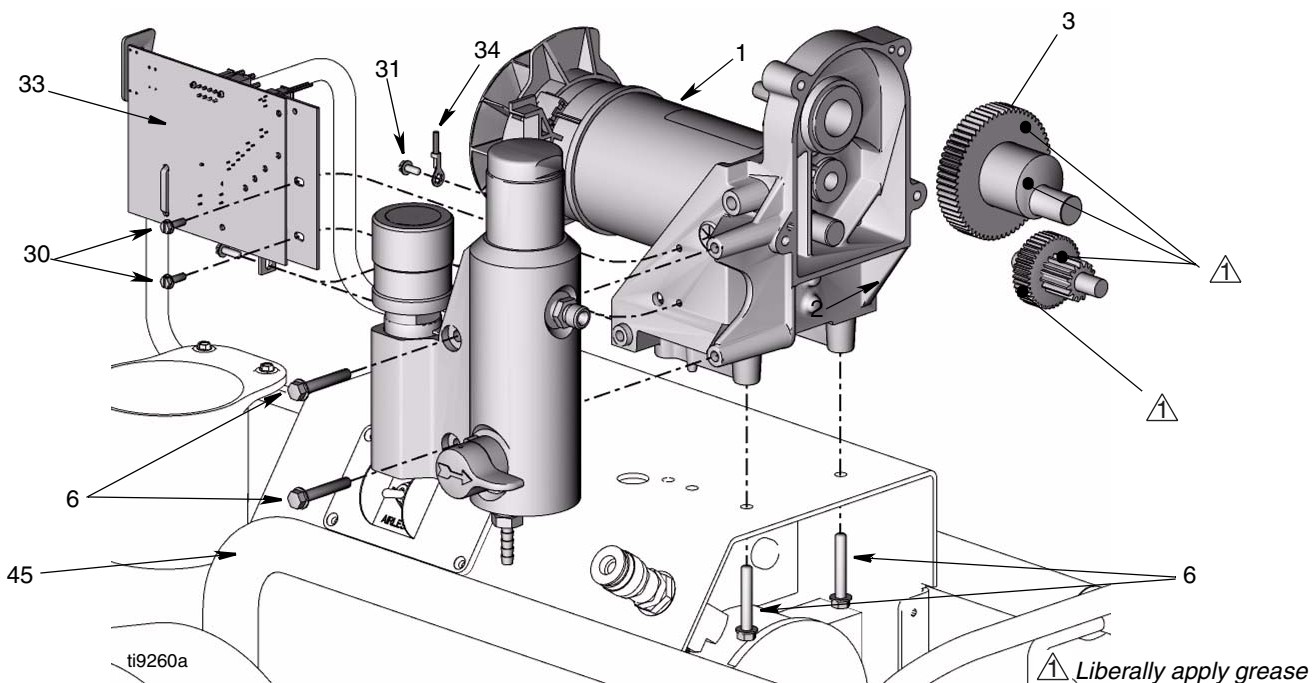

Motor Replacement

See *Wiring Diagram*, page 36.

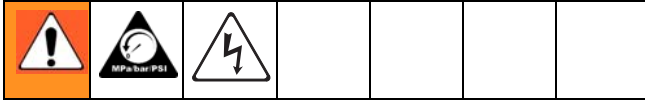

FinishPro 395

CAUTION

Do not drop gear cluster (44) and (40) when removing from drive housing (42). Gear cluster may stay engaged in motor front end bell or drive housing.

Removal

1. **Relieve pressure**, page 7.
2. Remove pump (41); **Displacement Pump Replacement**, page 13
3. Remove drive housing (42); **Drive Housing Replacement**, page 15.
4. Remove screws (12) from cover (50).
5. Disconnect all leads from board (49). Remove screws (6) and board.
6. Remove screws (47) and control box (48).
7. Remove screws (47) and manifold (15).
8. Remove screws (47) and motor (54) from frame (59).

Installation

1. Install new motor (54) on frame (59) with screws (47).
2. Install manifold (15) with screws (47).
3. Install control housing (48) with screws (47).
4. Install board (49) with screws (6). Connect all leads to board. See wiring diagram for your sprayer model on page 36.
5. Install drive housing (42); **Drive Housing Replacement**, page 15.
6. Install pump (41); **Displacement Pump Replacement**, page 13.

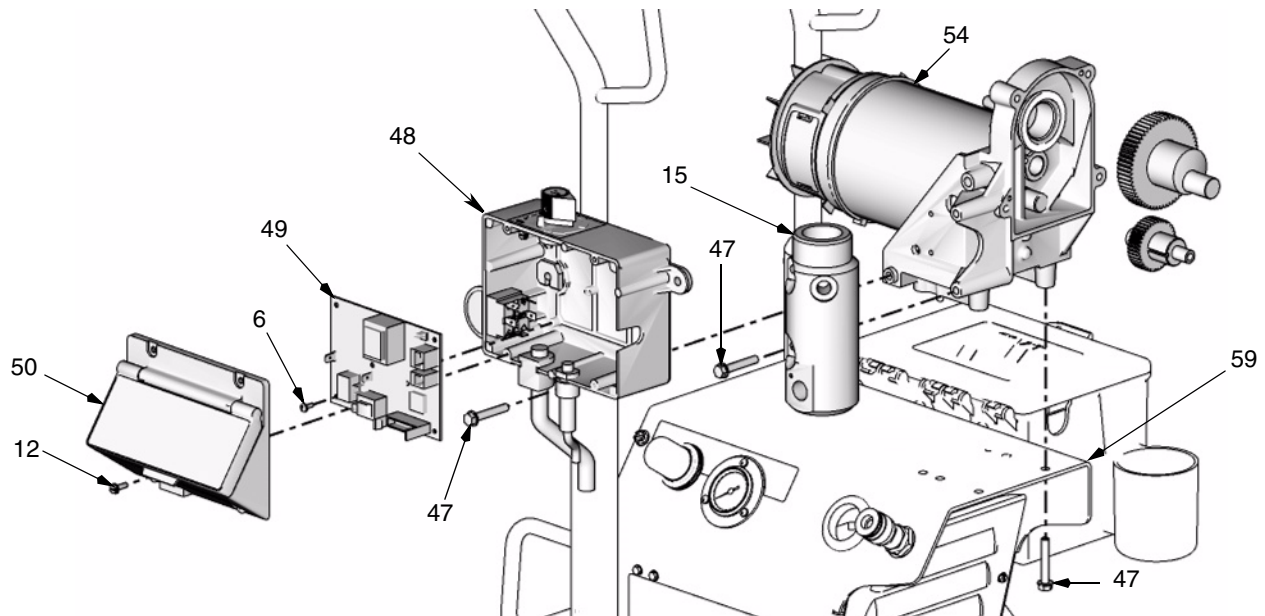

ti9605a

Wiring Diagram

FinishPro 395

120 Vac

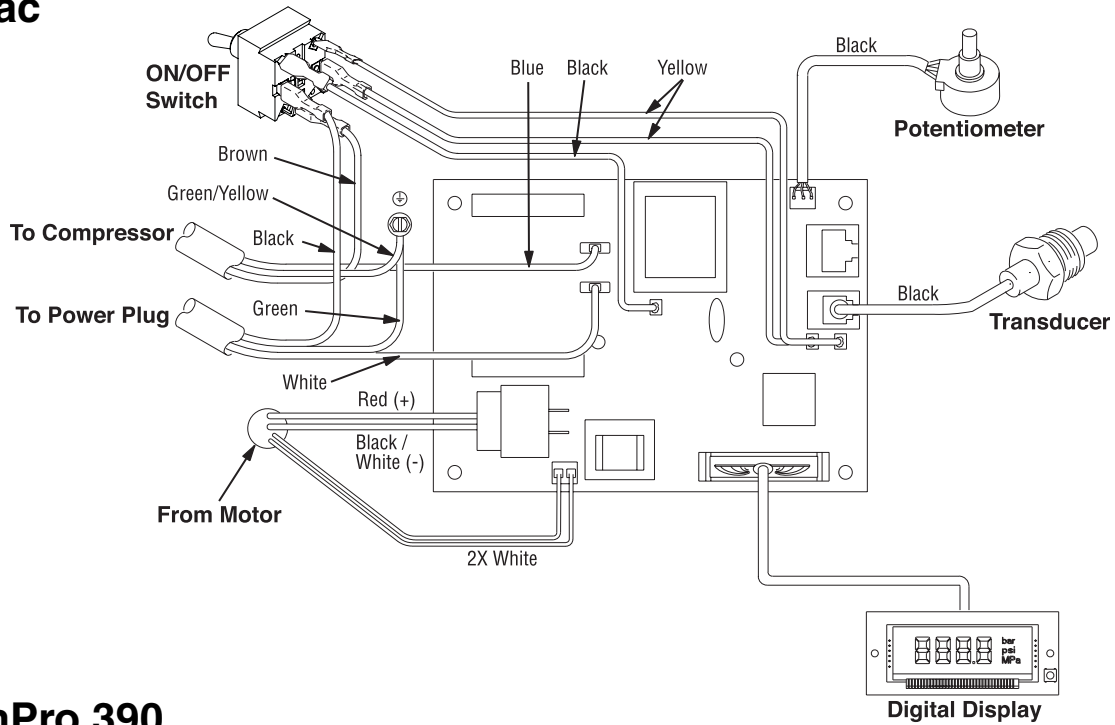

FinishPro 390

120 Vac

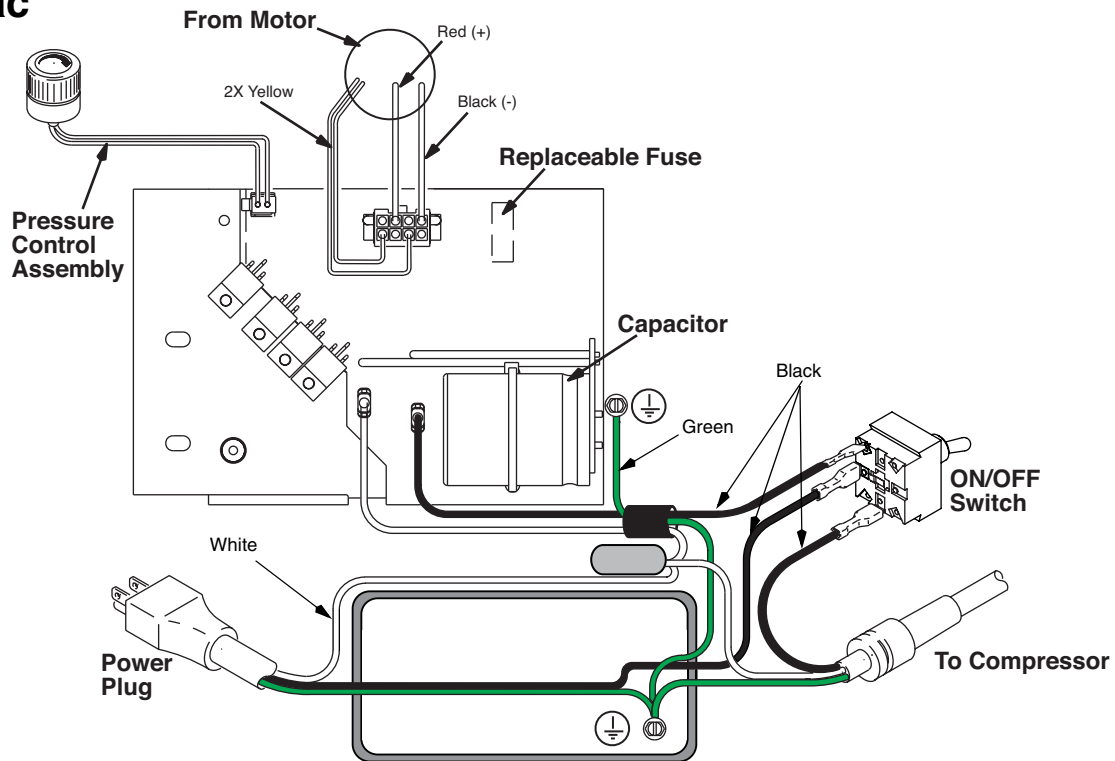

FinishPro 390 240 Vac

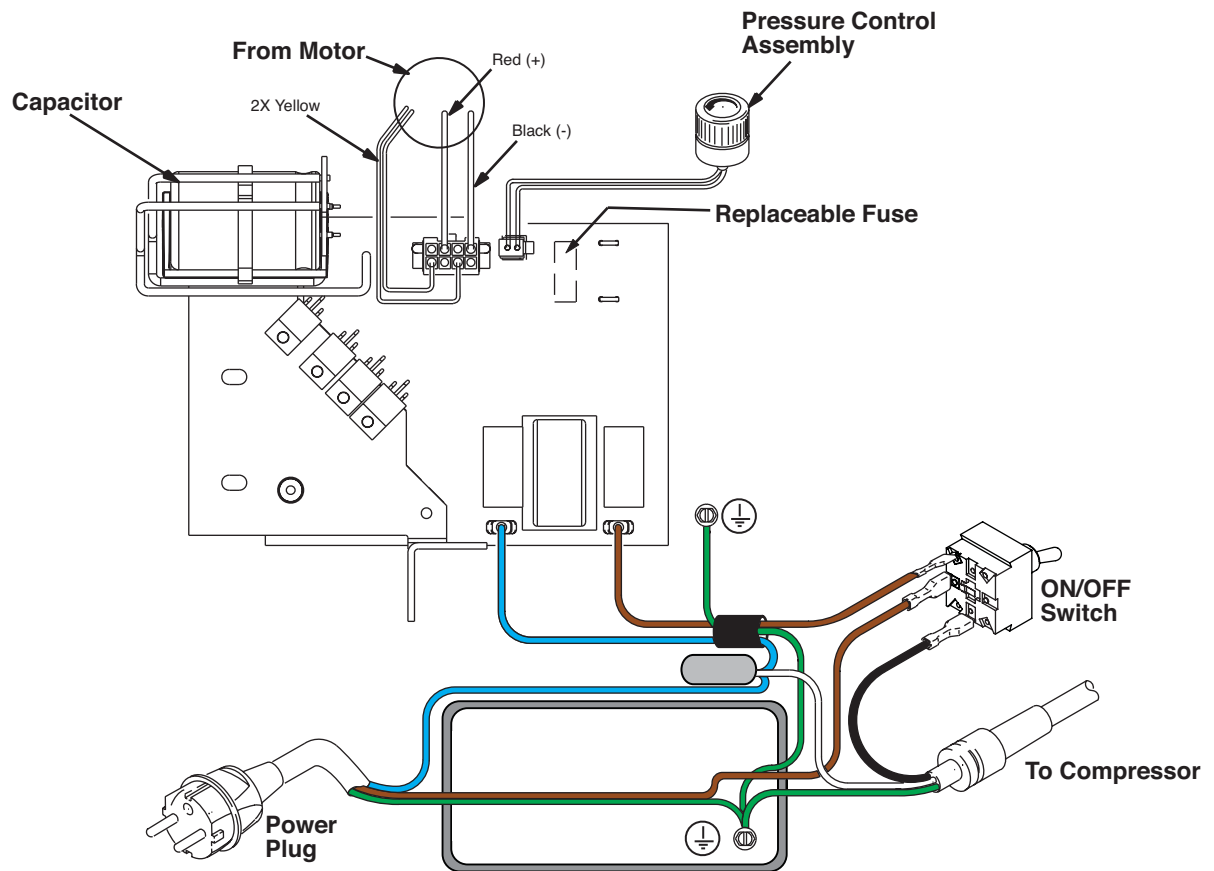

Technical Data

FinishPro 390 Models

FinishPro 395 Models

Power requirements	100/120 Vac, 50/60 Hz, 15A, 1 phase	230 Vac, 50/60 Hz, 10A, 1 phase	100/120 Vac, 50/60 Hz, 15A, 1 phase	230 Vac, 50/60 Hz, 10A, 1 phase
Max tip size	0.020	0.021	0.021	0.023
Max material output gpm (lpm)	.43 gpm (1.6 lpm)	.47 gpm (1.8 lpm)	.47 gpm (1.8 lpm)	.54 gpm (2.0 lpm)
Maximum material pressure - Airless	2600 psi (180 bar)	2600 psi (180 bar)	3300 psi (228 bar)	2600 psi (180 bar)
Maximum material pressure - AA	2600 psi (180 bar)	2600 psi (180 bar)	2800 psi (193 bar)	2600 psi (180 bar)
Atomizing air output	3.2 cfm	2.9 cfm	3.2 cfm	2.9 cfm
Air pressure	35 psi (2.4 bar)	35 psi (2.4 bar)	35 psi (2.4 bar)	35 psi (2.4 bar)
Pump motor	5/8 HP DC	5/8 HP DC	TEFC 7/8 HP DC	TEFC 7/8 HP DC
Compressor motor	1.0 HP AC Induction	1.0 HP AC Induction	1.0 HP AC Induction	1.0 HP AC Induction
Material hose	3/16 in. x 50 ft (blue)	3/16 in. x 50 ft (blue)	3/16 in. x 50 ft (blue)	3/16 in. x 50 ft (blue)
Air hose	3/8 in. x 50 ft (clear)	3/8 in. x 50 ft (clear)	3/8 in. x 50 ft (clear)	3/8 in. x 50 ft (clear)
Gun	G40 w RAC X tip	G40 w RAC X tip	G40 w RAC X tip	G40 w RAC X tip
Wetted parts	zinc-plated carbon steel, nylon, stainless steel, PTFE, acetal, chrome plating, leather, UHMWPE, aluminum, tungsten carbide			

Dimensions

FinishPro 390 Models

FinishPro 395 Models

Length	28 in. (71 cm)	28 in. (71 cm)
Width	22 in. (56 cm)	23 in. (58 cm)
Height	25 in. (64 cm)	32 in. (80 cm)
Weight - bare	78 lb (43.6 kg)	96 lb (43.6 kg)

Warranty

Graco warrants all equipment referenced in this document which is manufactured by Graco and bearing its name to be free from defects in material and workmanship on the date of sale to the original purchaser for use. With the exception of any special, extended, or limited warranty published by Graco, Graco will, for a period of twelve months from the date of sale, repair or replace any part of the equipment determined by Graco to be defective. This warranty applies only when the equipment is installed, operated and maintained in accordance with Graco's written recommendations.

This warranty does not cover, and Graco shall not be liable for general wear and tear, or any malfunction, damage or wear caused by faulty installation, misapplication, abrasion, corrosion, inadequate or improper maintenance, negligence, accident, tampering, or substitution of non-Graco component parts. Nor shall Graco be liable for malfunction, damage or wear caused by the incompatibility of Graco equipment with structures, accessories, equipment or materials not supplied by Graco, or the improper design, manufacture, installation, operation or maintenance of structures, accessories, equipment or materials not supplied by Graco.

This warranty is conditioned upon the prepaid return of the equipment claimed to be defective to an authorized Graco distributor for verification of the claimed defect. If the claimed defect is verified, Graco will repair or replace free of charge any defective parts. The equipment will be returned to the original purchaser transportation prepaid. If inspection of the equipment does not disclose any defect in material or workmanship, repairs will be made at a reasonable charge, which charges may include the costs of parts, labor, and transportation.

THIS WARRANTY IS EXCLUSIVE, AND IS IN LIEU OF ANY OTHER WARRANTIES, EXPRESS OR IMPLIED, INCLUDING BUT NOT LIMITED TO WARRANTY OF MERCHANTABILITY OR WARRANTY OF FITNESS FOR A PARTICULAR PURPOSE.

Graco's sole obligation and buyer's sole remedy for any breach of warranty shall be as set forth above. The buyer agrees that no other remedy (including, but not limited to, incidental or consequential damages for lost profits, lost sales, injury to person or property, or any other incidental or consequential loss) shall be available. Any action for breach of warranty must be brought within two (2) years of the date of sale.

GRACO MAKES NO WARRANTY, AND DISCLAIMS ALL IMPLIED WARRANTIES OF MERCHANTABILITY AND FITNESS FOR A PARTICULAR PURPOSE, IN CONNECTION WITH ACCESSORIES, EQUIPMENT, MATERIALS OR COMPONENTS SOLD BUT NOT MANUFACTURED BY GRACO. These items sold, but not manufactured by Graco (such as electric motors, switches, hose, etc.), are subject to the warranty, if any, of their manufacturer. Graco will provide purchaser with reasonable assistance in making any claim for breach of these warranties.

In no event will Graco be liable for indirect, incidental, special or consequential damages resulting from Graco supplying equipment hereunder, or the furnishing, performance, or use of any products or other goods sold hereto, whether due to a breach of contract, breach of warranty, the negligence of Graco, or otherwise.

ADDITIONAL WARRANTY COVERAGE

Graco does provide extended warranty and wear warranty for products described in the "Graco Contractor Equipment Warranty Program".

TO PLACE AN ORDER, contact your Graco distributor, or call **1-800-690-2894** to identify the nearest distributor.

All written and visual data contained in this document reflects the latest product information available at the time of publication. Graco reserves the right to make changes at any time without notice.

mm 311911
This manual contains English
Graco Headquarters: Minneapolis,
International Offices: Belgium, Korea, China, Japan

GRACO INC. P.O. BOX 1441 MINNEAPOLIS, MN 55440-1441
<http://www.graco.com>

2/2007